

# Mobile Merchandiser

MODELS MM4, MM6

Service Manual

Serial Numbers 122605 and Higher



*Fresh ideas in foodservice equipment*

## BKI LIMITED WARRANTY

2812 Grandview Dr. • Simpsonville, SC 29680 • USA  
(864) 963-3471 • Toll Free: (800) 927-6887 • Fax: (864) 963-5316

### WHAT IS COVERED

This warranty covers defects in material and workmanship under normal use, and applies only to the original purchaser providing that:

- ☐ The equipment has not been accidentally or intentionally damaged, altered or misused;
- ☐ The equipment is properly installed, adjusted, operated and maintained in accordance with national and local codes, and in accordance with the installation and operating instructions provided with this product.
- ☐ The serial number rating plate affixed to the equipment has not been defaced or removed.

### WHO IS COVERED

This warranty is extended to the original purchaser and applies only to equipment purchased for use in the U.S.A.

### COVERAGE PERIOD

- ☐ Warranty claims must be received in writing by BKI within one (1) year from date of installation or within one (1) year and three (3) months from data of shipment from the factory, whichever comes first.
- ☐ COB Models: One (1) Year limited parts and labor.
- ☐ COM Models: Two (2) Year limited parts and labor. COM convection ovens also have a two (2) year door warranty.
- ☐ CO1 Models: Two (2) Year limited parts and labor. Five (5) Year limited door warranty.
- ☐ BevLes Products: Two (2) Year limited parts and labor.
- ☐ Warranty period begins the date of dealer invoice to customer or ninety (90) days after shipment date from BKI, whichever comes first.

### WARRANTY COVERAGE

This warranty covers on-site labor, parts and reasonable travel time and travel expenses of the authorized service representative up to (100) miles round trip and (2) hours travel time and performed during regular, weekday business hours.

### EXCEPTIONS

Any exceptions must be pre-approved in advance and in writing by BKI. The extended door warranty on convection ovens years 3 through 5 is a parts only warranty and does not include labor, travel, mileage or any other charges.

### EXCLUSIONS

- ☐ Negligence or acts of God,
- ☐ Thermostat calibrations after (30) days from equipment installation date,
- ☐ Air and gas adjustments,
- ☐ Light bulbs,
- ☐ Glass doors and door adjustments,
- ☐ Fuses,
- ☐ Adjustments to burner flames and cleaning of pilot burners,
- ☐ Tightening of screws or fasteners,
- ☐ Failures caused by erratic voltages or gas suppliers,
- ☐ Unauthorized repair by anyone other than a BKI Factory Authorized Service Center,
- ☐ Damage in shipment,
- ☐ Alteration, misuse or improper installation,
- ☐ Thermostats and safety valves with broken capillary tubes,
- ☐ Freight - other than normal UPS charges,
- ☐ Ordinary wear and tear,
- ☐ Failure to follow installation and/or operating instructions,
- ☐ Events beyond control of the company.

### INSTALLATION

Leveling, as well as proper installation and check out of all new equipment - per appropriate installation and use materials - is the responsibility of the dealer or installer, not the manufacturer.

### REPLACEMENT PARTS

BKI genuine Factory OEM parts receive a (90) day materials warranty effective from the date of installation by a BKI Factory Authorized Service Center.

# Table of Contents

<b>Table of Contents</b> .....	<b>1</b>
<b>Introduction</b> .....	<b>2</b>
Safety Precautions.....	2
Safety Signs and Messages.....	2
Safe Work Practices .....	3
Safety Labels.....	5
<b>Installation</b> .....	<b>6</b>
Instructions For Shipping Damage .....	6
Location and Placement .....	6
Electrical Information .....	6
<b>Replacement Parts</b> .....	<b>7</b>
Assemblies .....	7
Control Box Assembly.....	7
Components .....	8
Accessories .....	9
<b>Wiring Diagrams</b> .....	<b>11</b>
<b>Notes</b> .....	<b>21</b>

---

## Introduction

Congratulations! You have chosen a **Mobile Merchandiser** that will give you many years of fine service from the original manufacturer, **BKI**.

The **BKI** name and trademark on this unit assures you of the finest in design and engineering — that it has been built with care and dedication — using the best materials available. Attention to the operating instructions regarding proper installation, operation, and maintenance will result in long lasting dependability to insure the highest profitable return on your investment.

### **NOTICE**

PLEASE READ THIS ENTIRE MANUAL BEFORE OPERATING THE UNIT. If you have any questions, please contact your **BKI** Distributor. If they are unable to answer your questions, contact the **BKI** Technical Service Department, toll free: 1-800-927-6887. Outside the U.S., call 1-864-963-3471.

### **Safety Precautions**

Always follow recommended safety precautions listed in this manual. Below is the safety alert symbol. When you see this symbol on your equipment, be alert to the potential for personal injury or property damage.



### **Safety Signs and Messages**

The following Safety signs and messages are placed in this manual to provide instructions and identify specific areas where potential hazards exist and special precautions should be taken. Know and understand the meaning of these instructions, signs, and messages. Damage to the equipment, death or serious injury to you or other persons may result if these messages are not followed.

#### **⚠ DANGER**

This message indicates an imminently hazardous situation that, if not avoided, will result in death or serious injury.

#### **⚠ WARNING**

This message indicates a potentially hazardous situation, which, if not avoided, could result in death or serious injury.

#### **⚠ CAUTION**

This message indicates a potentially hazardous situation, which, if not avoided, may result in minor or moderate injury. It may also be used to alert against unsafe practices.

#### **NOTICE**

This message is used when special information, instructions or identification are required relating to procedures, equipment, tools, capacities and other special data.

**Safe Work Practices**

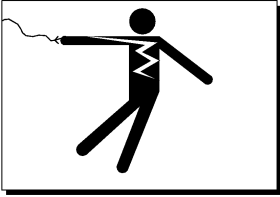

**Beware of High Voltage**

This equipment uses high voltage. Serious injury can occur if you or any untrained or unauthorized person installs, services, or repairs this equipment. Always Use an Authorized Service agent to Service Your Equipment.



**Keep this manual with the Equipment**

This manual is an important part of your equipment. Always keep it near for easy access. If you need to replace this manual, contact:

**BKI**

Technical Services Department  
 2812 Grandview Drive  
 Simpsonville, S.C. 29680  
 Or call toll free: 1-800-927-6887  
 Outside the U.S., call 864-963-3471



**Protect Children**

Keep children away from this equipment. Children may not understand that this equipment is dangerous for them and others.

NEVER allow children to play near or operate your equipment.

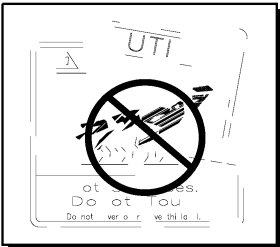

**Keep Safety Labels Clean and in Good Condition**

Do not remove or cover any safety labels on your equipment. Keep all safety labels clean and in good condition. Replace any damaged or missing safety labels. Refer to the Safety Labels section for illustration and location of safety labels on this unit. If you need a new safety label, obtain the number of the specific label illustrated on page 5, then contact:

**BKI**

Technical Services Department  
 2812 Grandview Drive  
 Simpsonville, S.C. 29680  
 Or call toll free: 1-800-927-6887  
 Outside the U.S., call 864-963-3471

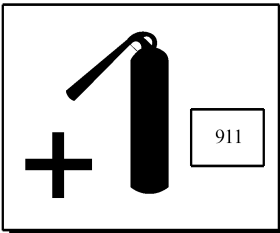

**Be Prepared for Emergencies**

Be prepared for fires, injuries, or other emergencies.

Keep a first aid kit and a fire extinguisher near the equipment. You must use a 40-pound Type BC fire extinguisher and keep it within 25 feet of your equipment.

Keep emergency numbers for doctors, ambulance services, hospitals, and the fire department near your telephone.

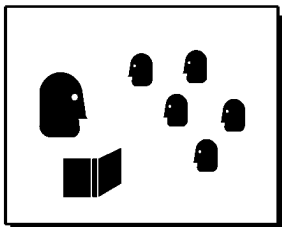

**Know your responsibilities as an Employer**

- Make certain your employees know how to operate the equipment.
- Make certain your employees are aware of the safety precautions on the equipment and in this manual.
- Make certain that you have thoroughly trained your employees about operating the equipment safely.
- Make certain the equipment is in proper working condition. If you make unauthorized modifications to the equipment, you will reduce the function and safety of the equipment.

Safety Labels

N0444

This lamp has been treated to resist breakage and must be replaced with a similarly treated lamp in order to maintain compliance with NSF standards.

N0444

N0516

This machine is intended for use with pre-packaged foods only.

N0516

N0202



**⚠ DANGER**

HIGH VOLTAGE. Turn power off before servicing. May have more than one disconnect switch. Do not cover or remove label. N0202

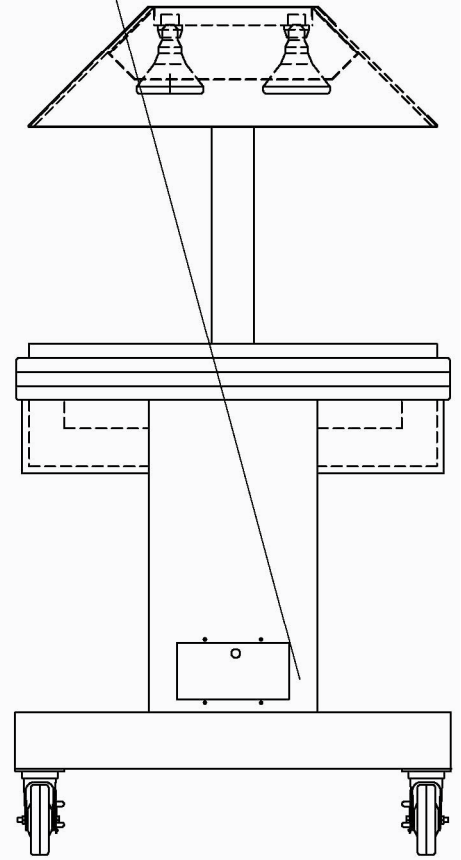
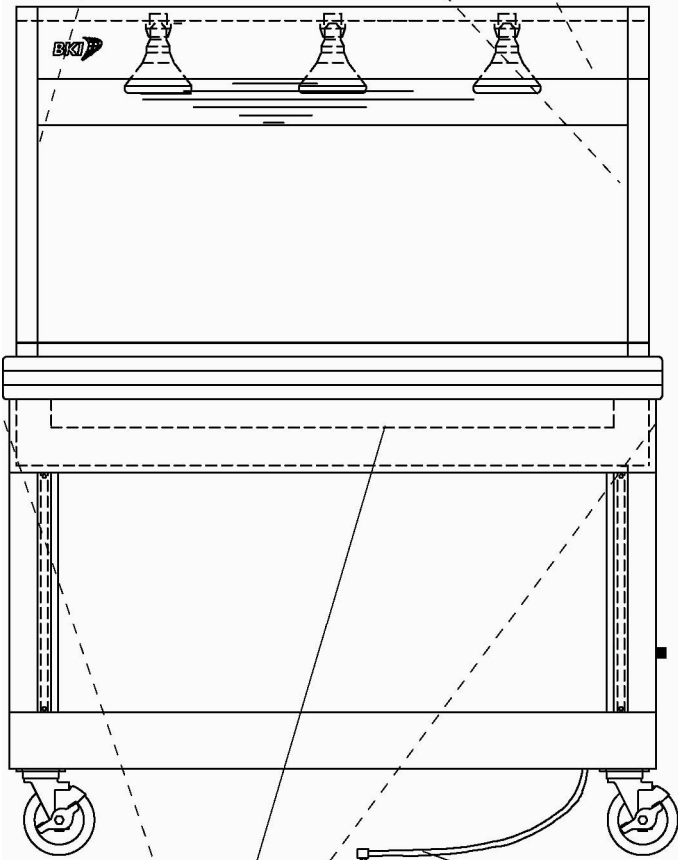

N0200



**⚠ CAUTION**

Hot surface can cause severe burns. Do not touch.

Do not cover or remove label. N-0200

N0158

**⚠ WARNING**

CONNECT ONLY TO APPROVED 3 PRONG GROUNDED CIRCUIT. FAILURE TO DO SO COULD RESULT IN SERIOUS INJURY.

**⚠ WARNING**

CONNECT ONLY TO APPROVED 3 PRONG GROUNDED CIRCUIT. FAILURE TO DO SO COULD RESULT IN SERIOUS INJURY.

**DO NOT COVER OR REMOVE THIS LABEL**

N0158

## Installation

**⚠ WARNING**

Serious injury, equipment damage or death could result if attempting to install this unit yourself. Ensure that an authorized BKI service agent installs the unit.

### ***Instructions For Shipping Damage***

You are responsible for filing all freight claims with the delivering truck line. Inspect all cartons and crates for damage when they arrive. If there is damage noted to shipping crates or cartons, or, if a shortage is found, note this on the bill of lading (all copies) before signing.

If damage is detected when the equipment is uncrated, immediately call the delivering truck line and follow up the call with a written report indicating concealed damage to your equipment. Ask for an immediate inspection of your concealed damage item. Crating material **MUST** be retained to show the inspector from the truck line.

### ***Location and Placement***

Move the unit to a permanent location and lock the swivel casters before using.

### ***Electrical Information***

**⚠ WARNING**

Electrocution, equipment failure or property damage could result if an unlicensed electrician performs the electrical installation. Ensure that a licensed electrician perform the electrical installation in accordance with local codes, or in the absence of local codes, with the National Electrical Code, ANSI NFPA 70-20XX.

This unit, when installed by an authorized BKI service agent, must be wired for use in accordance with all applicable local, state, and federal codes. For specific electrical requirements and connections refer to the wiring diagram attached to the unit or provided in the Service Manual.



## Replacement Parts

Use the information in this section to identify replacement parts. To order replacement parts, call your local BKI sales and service representative. Before calling, please note the serial number on the rating tag affixed to the unit.





### Assemblies



#### Control Box Assembly



ITEM #	PART #	QTY	DESCRIPTION
1	PL0014	1	PILOT LIGHT, Z770890300
2	K0019	1	KNOB, T-STAT BLK 1-10
3	R0002 or R0004	1	RELAY, 2 POLE 110/120V or RELAY, 2 POLE 208/240V
4	FH0001 or FH0003	1	FUSE HOLDER, 15A 300V HPF-EE or FUSE HOLDER, 20A 300V HPS-JJ
5	S0102 or S0107	2	SWITCH, RCKR SPST W/LITE 250V or SWITCH, RKR SPST 15A 125V LAMP
6	T0081	1	THERMOSTAT, 250V 450 DEG
7	F0097 or F0104	1	FUSE, 15A 300V SC15 TIME DELAY or FUSE, 20A 300V SC20 TIME DELAY

**Components**

PART #	QTY	DESCRIPTION	PICTURE
TG0024	1	THERMOMETER 100-220 F/C 36" CAP. (MM6 – for product 642613A only)	
TG0027	1	THERMOMETER 2" SOLAR SS FRT (MM4 – for product 642406B only)  THERMOMETER 2" SOLAR SS FRT (MM6 – for product 642606B only)	
C0406	4	CASTER, W/TOP PLATE 5"	
CS0024	1	CORD SET, 12/3 SJTO 8' 30" LEAD (MM4)	
CS0023		CORD SET, 250V 6' 12/3 SO (MM6 – for product 642605B only)	
AB64263400		CORD SET, 6' 120V (MM6)	
C0200 C0243	1	CALROD MM4, 120V 600W A2182-1 (Outer) CALROD MM4, 120V 600W U1-32-414-2 (Inner)	
C0204 C0205		CALROD MM6, 120V 1000W (Outer) CALROD MM6, 120V 1000W (Inner)	
C0299 C0311		CALROD MM4, 240V 600W (Outer) CALROD MM4, 240V 600W (Inner)	
C0312 C0313		CALROD MM4/MM6, 240V 1000W (Outer) CALROD MM4/MM6, 240V 1000W (Inner)	
C0318		CALROD MM6, 208V 1000W (Outer)	
C0319		CALROD MM6, 208V 1000W (Inner)	

PART #	QTY	DESCRIPTION	PICTURE
FL0028	6 10	LAMP, FLOOD 100W PAR38 120V (MM4) LAMP, FLOOD 100W PAR38 120V (MM6)	
FL0002	6 10	LAMP, FLOOD 175W PAR38 120V HEAT (MM4) LAMP, FLOOD 175W PAR38 120V HEAT (MM6)	
FL0003	6 10	LAMP, FLOOD 150W PAR38 240/250V (MM4) LAMP, FLOOD 150W PAR38 240/250V (MM6)	
LH0001	6 10	LAMPHOLDER, RD PORCELAIN (MM4) LAMPHOLDER, RD PORCELAIN (MM6)	

**Accessories**

PART #	QTY	DESCRIPTION	PICTURE
FB64242210	1	WELL RISER MM4	Figure 1
FB64265910	2	WELL RISER MM6	Figure 1
AN64267800	1	BREAD RACK SHELF FOR MM-4 (for product 642405B and 642418B only)	Figure 2
AN64267900	1	BREAD RACK SHELF FOR MM-6 (for product 642611B only)	Figure 2
AN64267700	2	BREAD BOX FOR MM-4 OR MM-6 (for product 642604B only)	Figure 2

**Figure 1.** Well Riser



Figure 2. Bread Rack & Bread Box



## Wiring Diagrams

Refer to the table below to find the wiring diagram associated with your unit.

Wiring Diagram	Part #	Figure #
MM4 120V/1 Phase (600W Heating Elements, FL0028 100W Lamp)	SB64291900	Figure 3
MM4 120V/1 Phase (600W Heating Elements, FL0002 175W Lamp)	SB64290500	Figure 4
MM4 120V/1 Phase (600W Heating Elements, FL0028 100W Lamp)	SB64291300	Figure 5
MM4 220V/1 Phase (504W Heating Elements, FL0003 150W Lamp)	SB64290900	Figure 6
MM4 230V/240V/1 Phase (600W Heating Elements, FL0003 150W Lamp)	SB64291800	Figure 7
MM6 120V/1 Phase (1000W Heating Elements, FL0028 100W Lamp, 20A fuse)	SB64292000	Figure 8
MM6 120V/1 Phase (1000W Heating Elements, FL0002 175W Lamp, 20A fuse)	SB64290100	Figure 9
MM6 208V/240V/1 Phase (1000W Heating Elements, FL0003 150W Lamp, 15A fuse)	SB64291700	Figure 10
MM6 240V/1 Phase ENGLAND (1000W Heating Elements, FL0003 150W Lamp, 15A fuse)	SB64290600	Figure 11

Figure 3. MM4 120V/1 Phase (600W Heating Elements, FL0028 100W Lamp)

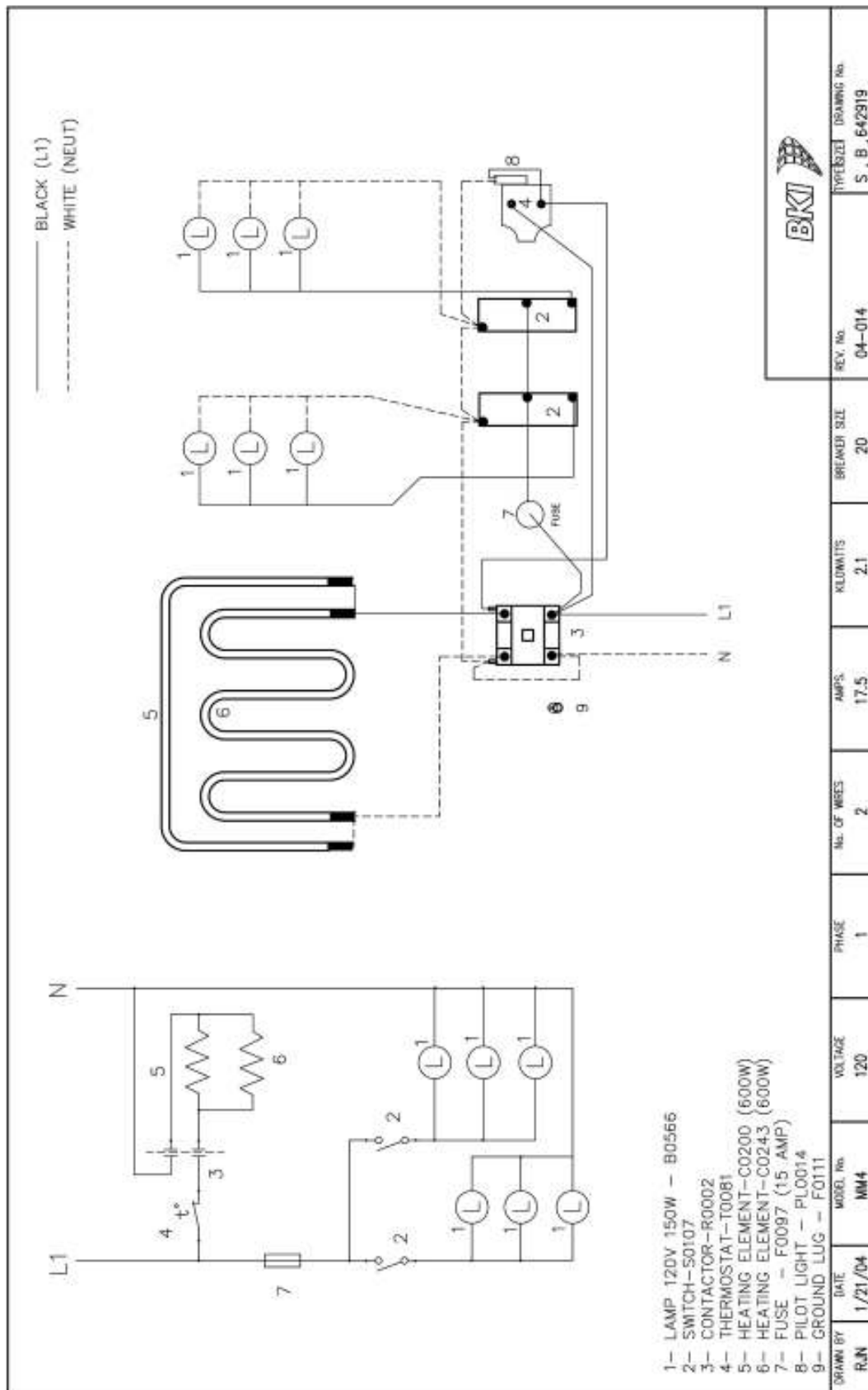

Figure 4. MM4 120V/1 Phase (600W Heating Elements, FL0002 175W Lamp)

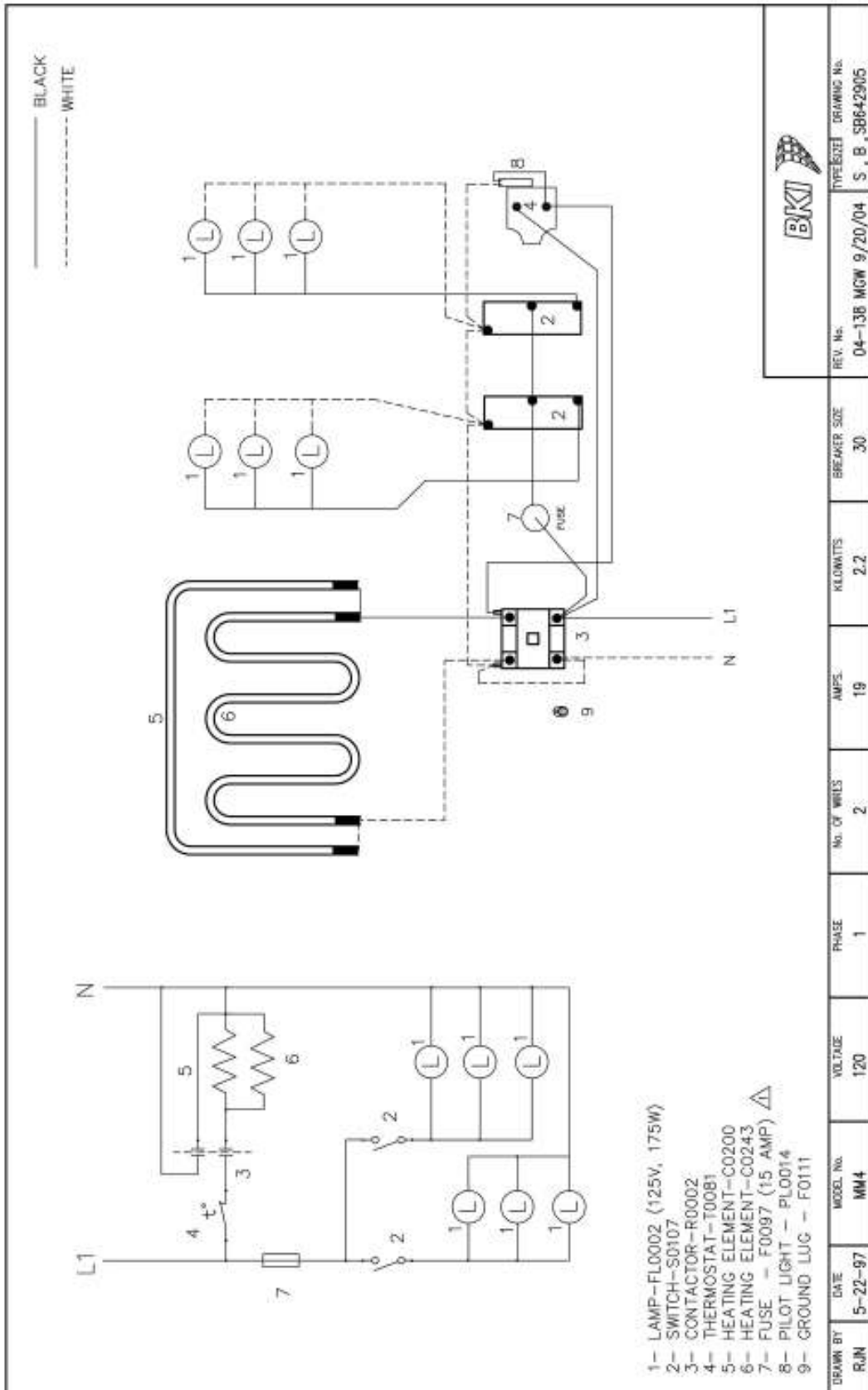

Figure 5. MM4 120V/1 Phase (600W Heating Elements, FL0028 100W Lamp)

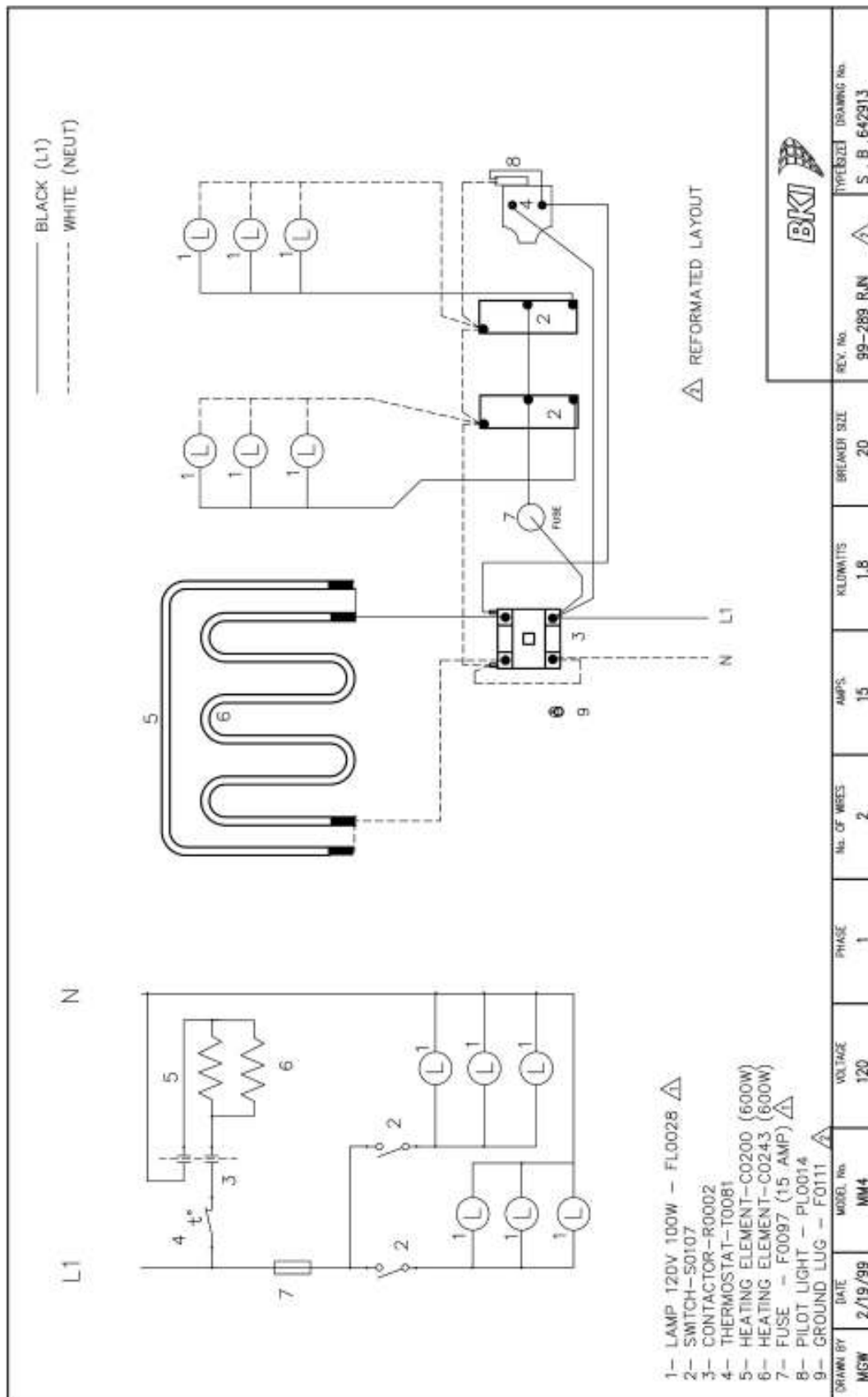



Figure 6. MM4 220V/1 Phase (504W Heating Elements, FL0003 150W Lamp)

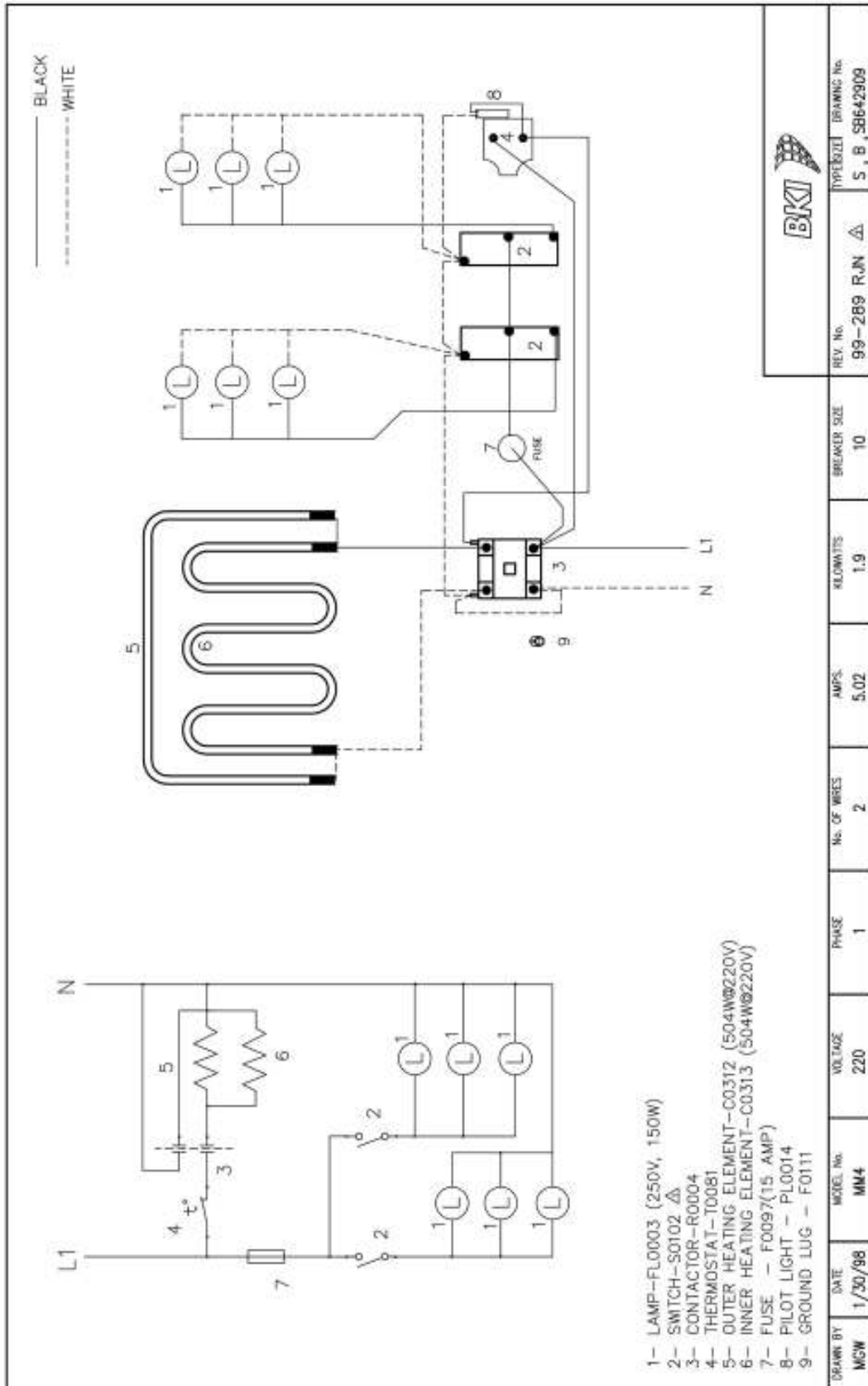

Figure 7. MM4 230V/240V/1 Phase (600W Heating Elements, FL0003 150W Lamp)

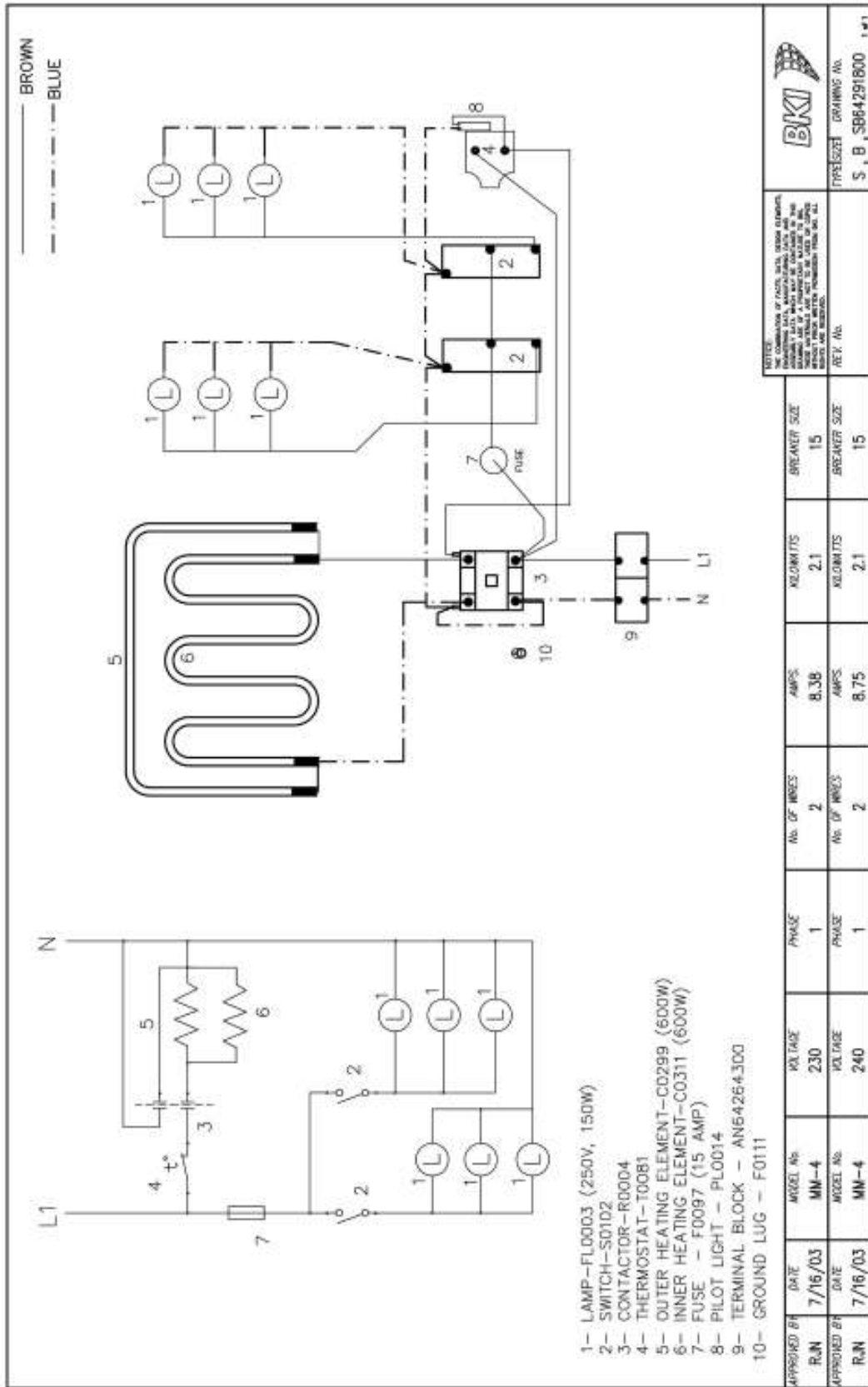

Figure 8. MM6 120V/1 Phase (1000W Heating Elements, FL0028 100W Lamp, 20A fuse)

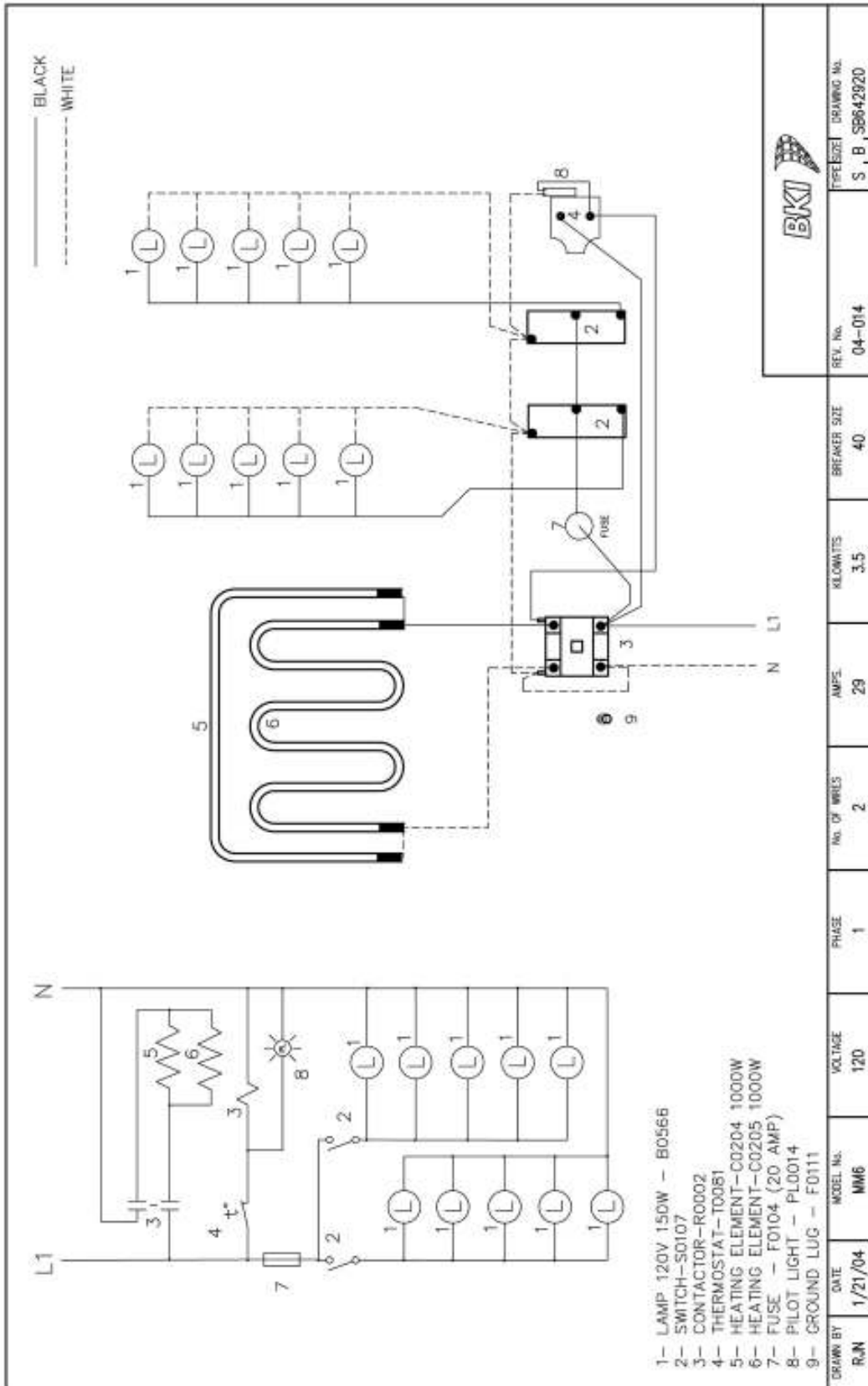

Figure 9. MM6 120V/1 Phase (1000W Heating Elements, FL0002 175W Lamp, 20A fuse)

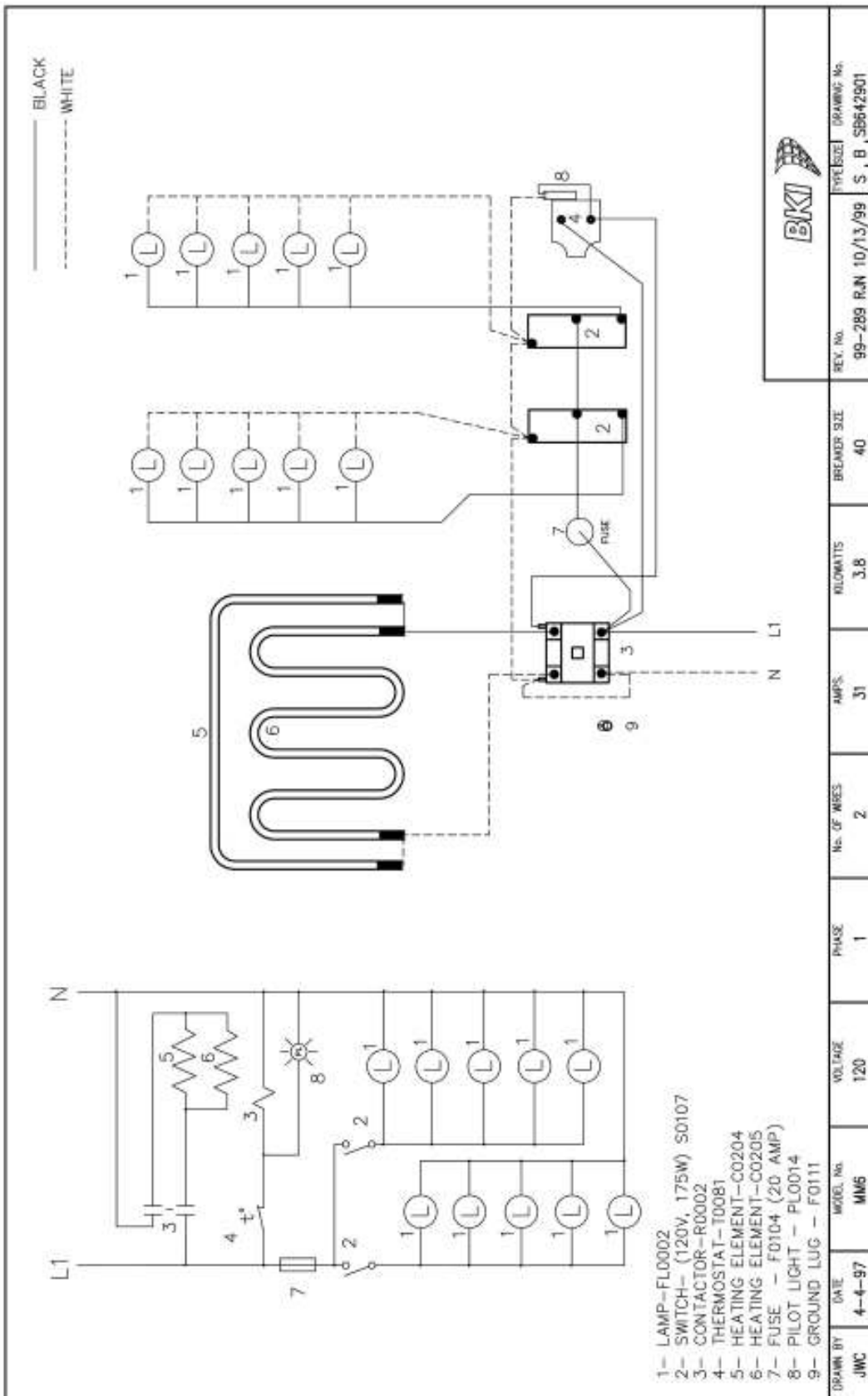

Figure 10. MM6 208V/240V/1 Phase (1000W Heating Elements, FL0003 150W Lamp, 15A fuse)

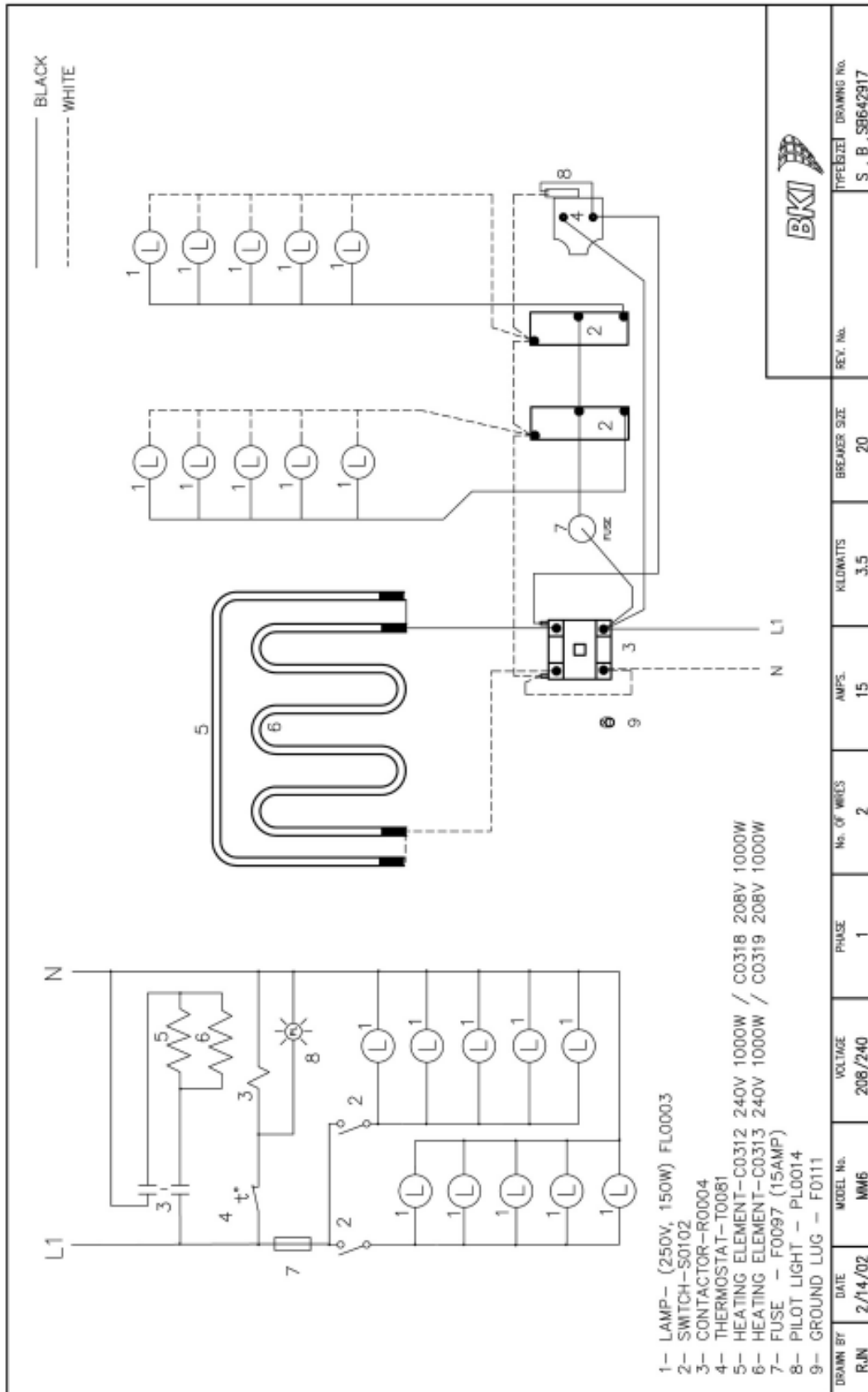
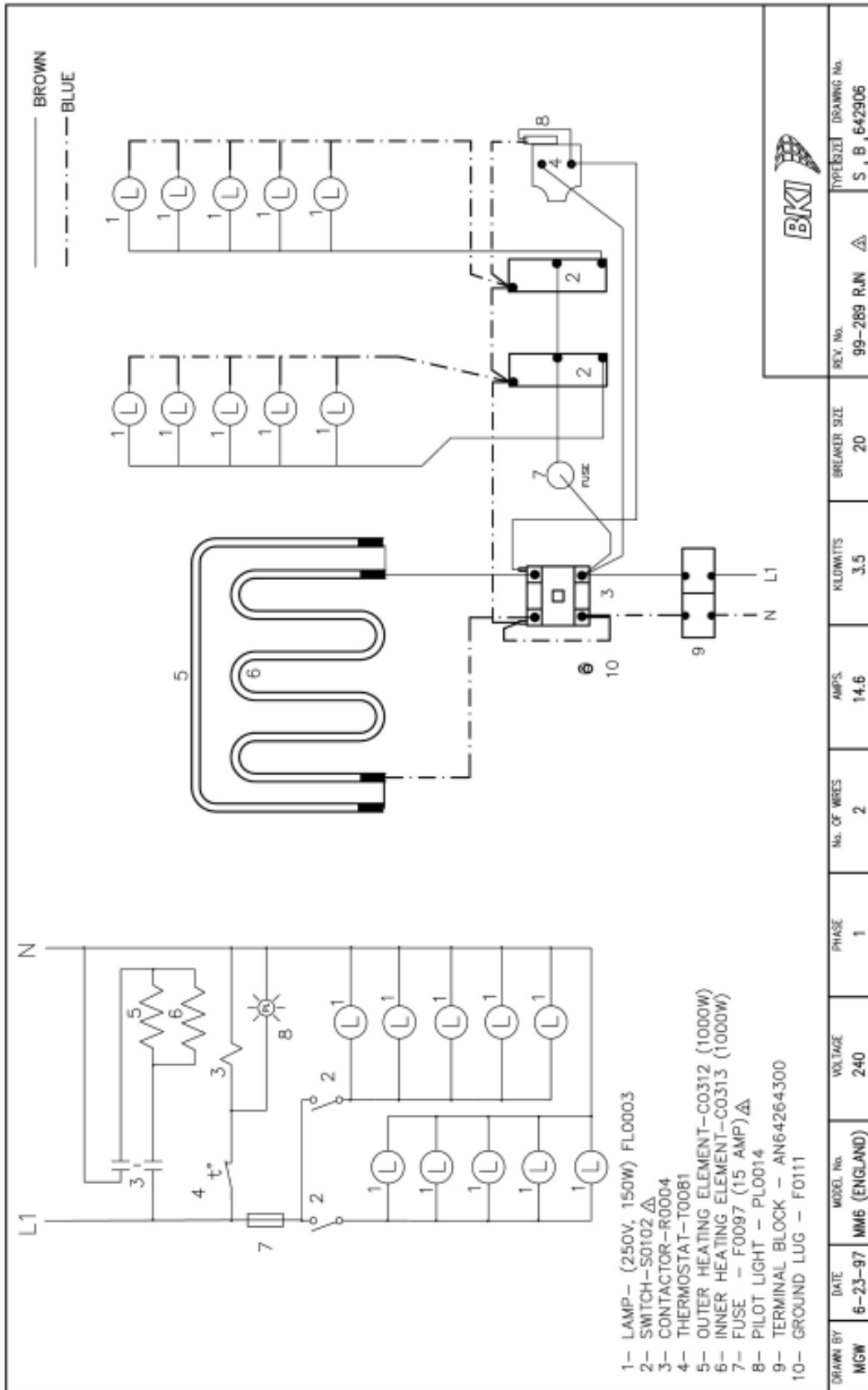

Figure 11. MM6 240V/1 Phase ENGLAND (1000W Heating Elements, FL0003 150W Lamp, 15A fuse)



REV. No.	99-289 R,UN	Δ
TYPE/REV	S, B	642906

REV. No.	99-289 R,UN	Δ
TYPE/REV	S, B	642906
BREAKER SIZE	20	
KILOWATTS	3.5	
AMPS	14.6	
NO. OF WIRES	2	
PHASE	1	
VOLTAGE	240	
MODEL No.	MM6 (ENGLAND)	
DATE	6-23-97	
DRAWN BY	MGW	

## Notes



2812 Grandview Dr., Simpsonville, S.C. 29680, USA  
<http://www.bkideas.com>

Made and printed in the U.S.A  
LI0268/0407

CS-TM-027.01

Revised 3/27/13



---

**REVISION HISTORY**

<b><u>REVISION</u></b>	<b><u>DATE</u></b>	<b><u>REVISED BY</u></b>	<b><u>DESCRIPTION</u></b>
01	03/27/13	KW	Initial Release-Supersedes all previous releases