



MODEL VTS-100 VACUUM TUMBLER

OPERATION MANUAL & PARTS LIST

STARTING WITH SERIAL NO. VT4



The BIRO VTS-100 VACUUM TUMBLERS are versatile machines used for vacuum tumbling all types of meats with marinated blends of herbs and spices. All marinades should be FDA approved and meet F.S.I. standards. The BIRO VTS-100 produces equally impressive results with beef, pork, poultry and fish.

The unit is both easy to clean and maintain as well as sanitary in design and construction. The entire machine is built to give many years of trouble free service while providing a unique line of marinated products for your customers.

TABLE OF CONTENTS

	Page
NOTICE TO OWNERS AND OPERATORS	1
SAFETY TIPS	2
OPERATION	3
CLEANING	4
MAINTENANCE	5
VACUUM PUMP FILTER	5, 6, 7
VACUUM PUMP	8, 9
LUBRICATION & MAINTENANCE FOR GEAR REDUCER	10, 11
PHOTOELECTRIC EYE OPERATING INSTRUCTIONS	12, 13
CONTROL PANEL – COMPONENTS	14
CONTROL PANEL – REAR VIEW	15
DRUM ASSEMBLY	16
FRAME ASSEMBLY AND COMPONENTS	17
VACUUM HOSES AND FITTINGS	18, 19
COMPONENT COVER AND REAR DOOR	20
WIRING DIAGRAMS	21, 22
RECOMMENDED SPARE PARTS AND NOTES	23
PREVENTATIVE MAINTAINANCE	24
OPERATOR'S SIGNATURE PAGE	25
LIMITED WARRANTY	26

NOTICE TO OWNERS AND OPERATORS

BIRO's products are designed to process food products safely and efficiently. Unless the operator is properly trained and supervised, however, there is the possibility of a serious injury. It is the responsibility of the owner to assure that this machine is used properly and safely, strictly following the instructions contained in this Manual and any requirements of local law.

No one should use or service this machine without proper training and supervision. All operators should read and be thoroughly familiar with the procedures contained in this Manual. Even so BIRO cannot anticipate every circumstance or environment in which its products will be used. You, the owner and operator, must remain alert to the hazards posed by the function of this equipment. No one under eighteen (18) years of age should operate this equipment. If you are uncertain about a particular task, ask your supervisor.

This Manual contains a number of safe practices in the SAFETY TIP section. Additional warnings are placed throughout the Manual. Warnings related to your personal safety are indicated by:



OR



Warnings related to possible damage to equipment are indicated by:



BIRO also has provided warning labels on the equipment. If any warning label, instruction label or Manual becomes misplaced, damaged, or illegible, please contact your nearest Distributor or BIRO directly for a replacement.

Remember, however, this Manual or the warning labels do not replace the need to be alert and to use your common sense when using this equipment.

– NOTE –

A copy of this manual is included with each Model VTS-100 Vacuum Tumbler.

**The descriptions and illustrations contained in this manual are not binding.
The manufacturer reserves the right to introduce any modification without
updating the manual.**

SAFETY TIPS



ROTATING DRUM TO AVOID SERIOUS PERSONAL INJURY

***NEVER** Touch This Machine Without Training and Authorization By Your Supervisor.*

***ALWAYS** Read Operation and Service Manual **BEFORE** Operating, Cleaning or Servicing.*

***ALWAYS** Keep Hands Clear of the Rotating Drum and Other Moving Parts.*

***NEVER** Attempt to Remove the Drum Lid Unless Vacuum Has Been Released and the Drum is Positioned Vertically With the Lid at the Top.*

***NEVER** Operate Vacuum Pump Unless Properly Connected to Tumbler Drum.*

***ONLY** Operate Vacuum Pump in Recommended Vacuum Range (15-20 Inches of Mercury)
NEVER TO EXCEED 20 INCHES Hg.*

***ONLY** Use a Qualified Electrician to Install According to Local Building Codes: Machine **MUST** Be Properly Grounded.*

***ONLY** Install on Level, Non-Skid Surface in a Clean, Well-Lighted Work Area Away From Children and Visitors.*

***DO NOT** Allow Food Particles, Liquids or Any Other Foreign Material to Enter the Vacuum Pump or Vacuum Hose.*

***ALWAYS** Turn Off, Unplug From Power Source and Perform Lockout/Tagout Procedure to This Machine **BEFORE** Cleaning or Servicing.*

***NEVER** Leave Machine Unattended While Operating.*

***PROMPTLY REPLACE** Any Worn or Illegible Warning and/or Instruction Labels.*

***USE ONLY BIRO** Parts and Accessories Properly Installed.*

FOOD HANDLING TO PREVENT CONTAMINATION

1. **ALWAYS** wash hands thoroughly with warm soap and water before and after handling raw fish, poultry or meats.
2. **ALWAYS** clean and sanitize all utensils and surfaces that have been in contact with raw products.
3. **ALWAYS** store cold foods at or below 45 deg. F (7.2 deg. C).

OPERATION



ROTATING DRUM

ONLY Properly Trained Personnel Should Use This Equipment.

ALWAYS Keep Hands Clear of the Rotating Drum and Other Moving Parts.

DO NOT Tamper With, Bypass, Alter, or Modify This Equipment in Any Way From Its Original Condition.

ALWAYS Turn Off, Unplug From Power Source and Perform Lockout/Tagout Procedure to This Machine Before Cleaning, Servicing, or When Not In Use.

NEVER Leave Unattended While Operating.

NEVER Turn Drum by Hand, Jog Machine Until Drum is in Desired Position.

ALWAYS Comply With All Regulation for Food Handling, Packaging, and Storage.

NEVER Operate Without All Warning or Instruction Labels Attached.

TO PROCESS PRODUCT

1. Weigh product to be vacuum tumbled.
2. Refer to your ingredient chart for proper amount of marinade seasoning and water.
3. Use jog switch to position drum opening upright.
4. Place product, marinade and water into tumbler drum.
5. Install gasket on drum and place cover on drum and secure with four latches.
6. Connect vacuum hose to valve on drum. Be sure valve handle is in the open position, Parallel with the valve body.
7. Turn vacuum pump to "ON". (Vacuum gauge will start indicating a vacuum is being pulled in the drum.) If needle in vacuum gauge does not indicate vacuum is being pulled, turn "OFF" vacuum pump and disconnect vacuum hose from drum lid. Remove drum lid and check that the lid gasket is properly installed and seated, then repeat this procedure.
8. When vacuum gauge does indicate that a vacuum is being pulled, allow to continue running until gauge reads between 15 and 20 inches Hg. **NEVER TO EXCEED 20" Hg.**
9. Close valve handle on drum lid, Perpendicular to valve body. Turn vacuum pump to "OFF" position. Remove vacuum hose from valve. Drum contents are now sealed in a vacuum.
10. Program timer to desired tumble time, and press green button to start, drum will start turning.
11. Turn speed control knob to desired RPM.
12. Drum will stop when time runs out.
13. Turn off motor, jog drum until opening is in upright position. **NEVER TURN DRUM BY HAND.**
14. Turn valve handle to open position Parallel with valve body to release vacuum. Remove drum lid.
15. Remove product from drum.
16. Unplug machine and refer to cleaning instructions.

CLEANING



ROTATING DRUM TO AVOID PERSONAL INJURY

ALWAYS Turn Off, Unplug From Power Source and Perform Lockout/Tagout Procedure to This Machine **BEFORE** Cleaning or Servicing.

ONLY Use Recommended Cleaning Equipment, Materials and Procedures.

NEVER Spray Water or Other Liquid Substances Directly at Motor, Power Switch or any Other Electrical Components.

ALWAYS Thoroughly Clean Equipment at Least Daily.



DO NOT Use Harsh Chemicals, Scouring Pads or Cleansers. Ordinary Liquid Detergent for Manual Dish Washing or Pot/Pan Washing Will Not Harm the Machine. Dish Machine Chemicals Will Cause Brown Stains, as will Chlorine Bleach and Similar Products if Allowed to Stand in or on the Machine for Any Length of Time.

CLEANING THE BIRO VACUUM TUMBLER:

1. Turn "OFF", unplug machine from power source, and perform lockout/tagout procedures.
2. The drum, drum lid, and gasket can be removed and washed in utensil sink. Be sure to flush the vacuum valve on drum with warm soapy water and rinse with clean water thoroughly. The drum, drum lid, and gasket should be sanitized with an appropriate sanitizer approved by your local Health Dept. All parts should be air dried before reassembly and storage.
3. The exterior of the tumbler base and drum can be pressure washed with the same type soap solution followed by a rinse water wiping.
4. If food stains are not removed, use a product such as "Bon Ami" or "Soft Scrub". Be sure to scrub with the grain of the Stainless Steel with a soft cloth or sponge.
5. Streaks or water spots can usually be removed with a solution of vinegar and water.

MAINTENANCE



ROTATING DRUM

TO AVOID SERIOUS PERSONAL INJURY

ALWAYS Turn Off, Unplug From Power Source and Perform Lockout/Tagout Procedure to This Machine **BEFORE** Servicing.

NEVER Touch This Machine Without Training and Authorization By Your Supervisor.

NEVER Bypass, Alter, or Modify This Equipment in Any Way From Its Original Condition.

PROMPTLY REPLACE Any Worn or Illegible Labels.

USE ONLY GENUINE BIRO Parts and Accessories Properly Installed.

A. PUMP FILTER No. VTS529

1. Check filter daily. Filter must be drained before the separated moisture and oil reaches the bottom of the lower black baffle. Drain by unscrewing the black drain plug in bottom of sight bowl.
2. The filter element No. VTS529-1 should be removed and cleaned monthly.
 - a. Unscrew the black locking collar.
 - b. Remove bowl and locking collar.
 - c. Unscrew the black baffle at the bottom of the filter.
 - d. Clean bowl and filter element. Reinstall the filter element. Clean bowl with mild soap and water only. Do not use detergents, cleansing agents, such as acetone, alcohol, benzene or gasoline, which are damaging to plastic.
 - e. Lubricate bowl lip to assist initial sealing. Use only mineral based oils or grease. Do not use synthetic oils or silicones.

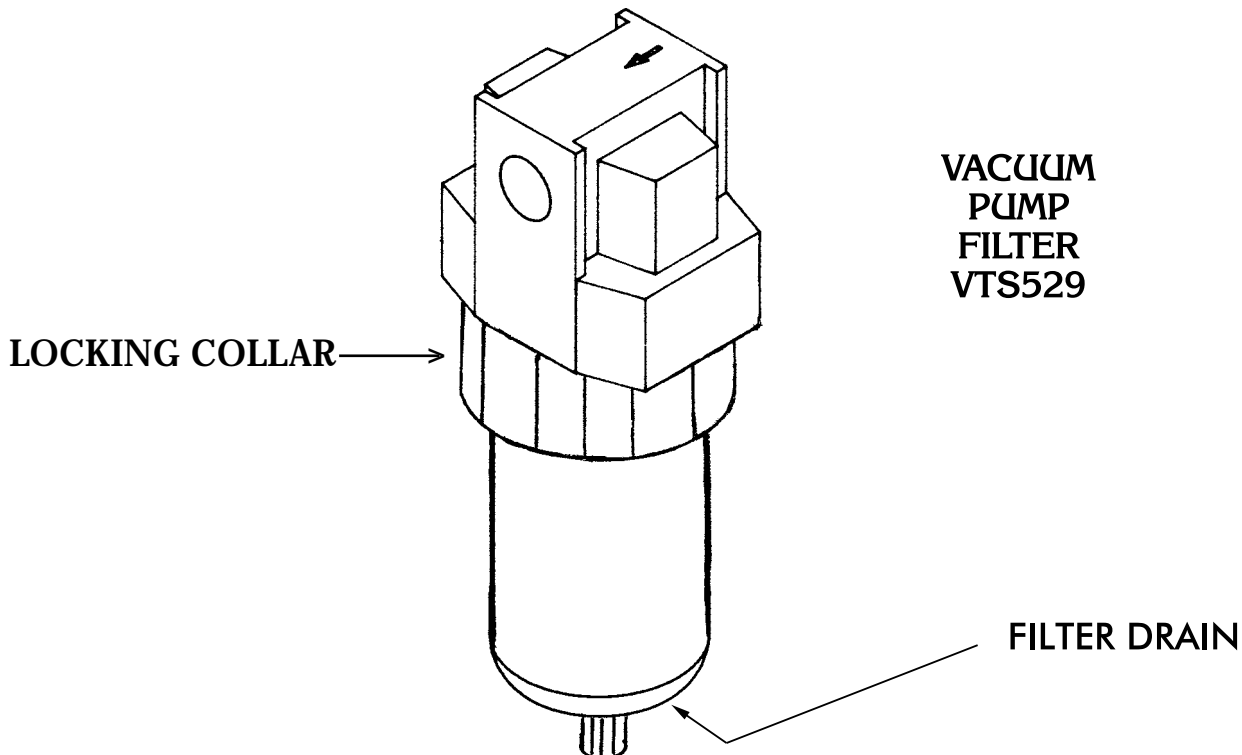

VTS529 FILTER MAINTENANCE

DAILY: Drain all separated moisture and oil from the filter enclosure. Depress the orange button at the bottom of the sight bowl.

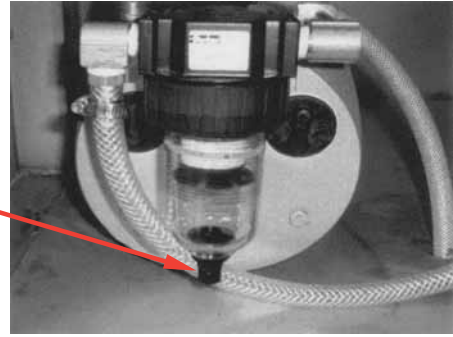

MONTHLY: The Part No. VTS529-1 filter element must be replaced once a month for proper vacuum and pump operation. Three (3) replacement filters have been included with your machine.



1. Unscrew the bowl locking collar.

2. Remove the clear bowl and locking collar and set aside.



3. Unscrew the filter holder. Lower the filter carefully from the mounting stud. Note the order of parts.



4. Separate the filter from the filter holders. Replace with a new filter.



5. Reassemble the filter in the reverse order. **Take special care that the locking ring is fully seated and tight. HAND TIGHTEN ONLY.**

CAUTION

The Part No. VTS529-1 filter element must be replaced once a month for proper vacuum pump operation. Three (3) replacement filters have been included with your tumbler. Order replacement filters Part No. VTS529-1 from the agency from whom you purchased the machine as needed.

NOTE: Review filter instructions in operation and service manual.

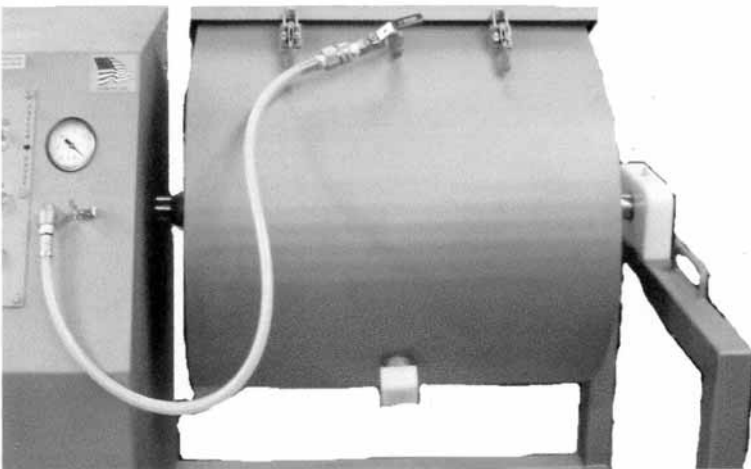

RECOMMENDED TECHNIQUE

AFTER FILLING THE DRUM WITH PRODUCT AND MARINADES.

INSTALL AND LOCK THE LID DOWN.

JOG THE DRUM UNTIL THE VACUUM FITTING IS POINTING UP AS SHOW, THIS WILL HELP MINIMIZE THE POSSIBILITY OF LIQUID BEING DRAWN INTO THE VACUUM PUMP.

THE BIRO MANUFACTURING CO.

Ph. (419) 798-4451

E-mail: service@birosaw.com

B. VACUUM PUMP

WARNING: MAKE SURE THE ELECTRIC MOTOR IS PROPERLY GROUNDED AND THE WIRING IS DONE BY A QUALIFIED ELECTRICIAN FAMILIAR WITH NEMA MG2 SAFETY STANDARDS, NATIONAL ELECTRICAL CODE AND ALL LOCAL SAFETY CODES.

WARNING: THE MOTOR IS THERMALLY PROTECTED AND CAN AUTOMATICALLY RESTART WHEN THE OVERLOAD RESETS. ALWAYS DISCONNECT FROM POWER SOURCE BEFORE SERVICING. PERSONAL INJURY COULD BE THE RESULT.

WARNING: DO NOT USE KEROSENE OR OTHER COMBUSTIBLE SOLVENTS TO FLUSH UNIT. USE ONLY GAST BRAND AH255 FLUSHING SOLVENT OR EQUIVALENT.

- CONSTRUCTION:** The end plate, body, rotor and all mounting brackets are cast iron. Any moisture that accumulates in the pump will tend to corrode the interior, especially if it stands idle. The muffler box, on the front of the unit, is made of aluminum. The vanes are made of hard carbon and are precision ground. They should last many thousand hours depending on degree of vacuum at which the pump is run.
- STARTING:** *CAUTION: NEVER LUBRICATE THIS OILLESS AIR PUMP.* The carbon vanes and grease packed motor bearings require no oil. If the motor fails to start or slows down when under load, shut the unit off and unplug. Check that the supply voltage agrees with the motor post terminals and motor data name plate. If the pump is extremely cold, allow it to warm to room temperature before starting.
- FLUSHING:** Should excessive dirt, foreign particles, moisture, or oil are permitted to enter the pump the vanes will act sluggish or even break. Flushing the pump should remove these materials. There are two options for performing this operation. **Option 1:** You will need two pipe nipples at least 4" long with $\frac{3}{8}$ " NPT on one end. 1) Remove the filter elements from the front of the muffler box and screw the nipples in through the same holes. 2) With the pump running allow about 2 tbsp. of flushing solvent to be ingested into the vacuum side of the unit. *CAUTION: WEAR EYE PROTECTION AND FLUSH IN A WELL VENTILATED AREA.* Repeat the flushing procedure. If it does not remedy the situation, remove the end plate for further examination. **Option 2:** Remove the filter elements from the front of the muffler box and carefully remove the five bolts that hold the muffler box in place (be careful not to damage the gaskets and it may be necessary to replace them). Tap the box with a small hammer to break it loose. **DO NOT PRY WITH A SCREWDRIVER** as the gasket will be damaged. This will allow access to the intake and exhaust ports.
- DISASSEMBLY:** If flushing does not eliminate the problem, remove the six bolts holding the end plate to the body. Now remove the end plate and the four vanes (do not remove the rotor or loosen any electric motor through bolts). The vanes could be worn or could require further cleaning. The top clearance (between the rotor and body) may be adjusted by: 1) loosen body bolts, 2) lightly tap on the pump body and turn the rotor while setting this clearance to assure all points on the rotor clear the body.

REASONS FOR PROBLEM	LOW		HIGH		PUMP	MOTOR
	VAC.	PRESS.	VAC.	PRESS.	OVERHEATING	OVERLOAD
Filter dirty	X	X	at pump		X	X
Muffler dirty				at pump	X	X
Vacuum line collapsed	X		at pump		X	X
Relief valve set too high			X	X	X	X
Relief valve set too low	X	X				
Plugged vacuum line	X	X	at pump	at pump	X	X
Vanes sticking	X	X				
Running at too high RPM			X	X	X	X
Vanes worn (replace)	X	X				
Shaft seal worn (replace)	X	X				
Dust or offset powder in pump	X	X			X	X
Motor not wired correctly	X	X			X	

VTS1034-1 3/4 HP VACUUM PUMP

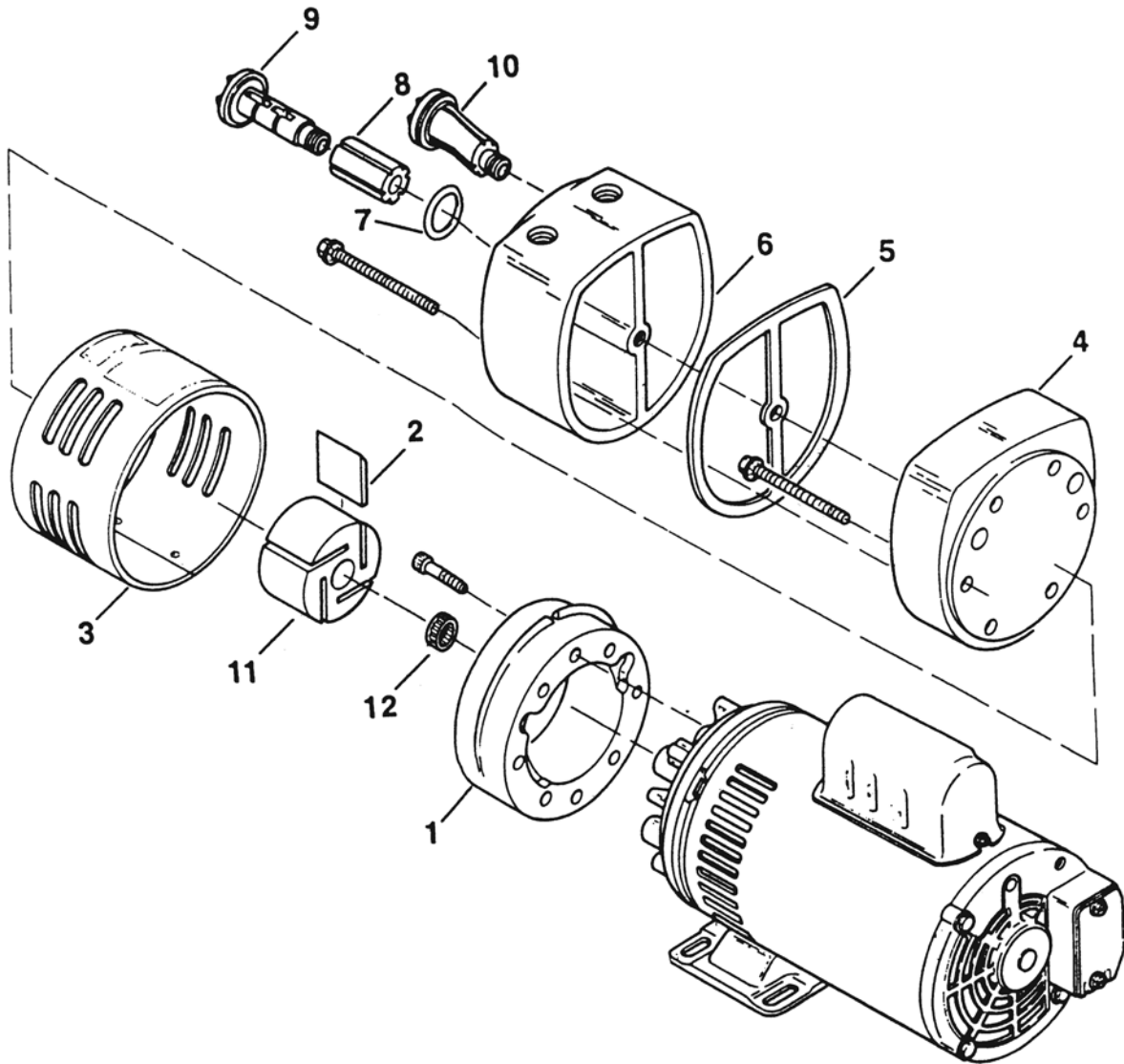

1	VTS-AK518	Pump body	1 req'd.
+2	VTS-AK513	Vane	4 req'd.
3	VTS-AK511	Pump shroud	1 req'd.
4	VTS-AK514	Pump end plate	1 req'd.
+5	VTS-AK522	Gasket	1 req'd.
6	VTS-AK520	Muffer box	1 req'd.
+7	VTS-AK473	O-ring	2 req'd.
+8	VTS-AK524	Felt	2 req'd.
9	VTS-AK510	End cap	2 req'd.
10	VTS-AK526	End cap assembly, 8 & 9	2 req'd.
11	VTS-AK512	Rotor	1 req'd.
12	VTS-AD126	Tolerance ring	1 req'd.

NOT SHOWN

+	VTS1034-1K	Service kit (consists of 2, 5, 7, 8) – K479
---	------------	---

11 & 12 Should not be replaced in field

LUBRICATION FOR GROVE GEAR REDUCER

1. Factory Filling

The speed reducers are oil filled at the factory to the proper level for the standard mounting position. The oil level should be checked and adjusted (if necessary) prior to operation, using the oil level plug provided and while the unit is oriented in its operating position.

2. Oil Changing



**WHEN CHANGING OIL FOR ANY REASON,
DO NOT MIX DIFFERENT OILS IN THE REDUCER.
OILS SHOULD BE COMPATIBLE WITH
VITON® SEAL MATERIAL.**

Therefore, when changing to a different oil, it is recommended that the housing be completely drained and thoroughly flushed with a light flushing oil prior to refilling with the appropriate lubricant. The oil level should be rechecked after a short period of operation and adjusted, if necessary.



**OIL SHOULD BE CHANGED MORE OFTEN IF THE
REDUCER IS USED IN A SEVERE ENVIRONMENT
(i.e., DUSTY, HUMID)**

A. Initial Oil Change

The oil in a new speed reducer should be changed at the end of 250 hours of operation. (30 days for 8 hour per day service, 15 days for 16 hour service, 10 days for 24 hour service.)

All standard reducers ordered from the factory are filled with lubricant to operate within a 30° to 100°F ambient temperature range.

B. Subsequent Oil Changes

Under normal conditions, after the initial oil change, the oil should be changed after every 2500 hours of operation, or every six months, whichever occurs first. Under severe conditions (rapid temperature changes, moist, dirty or corrosive environment) it may be necessary to change oil at intervals of one to three months. Periodic examination of oil samples taken from the unit will help establish the appropriate interval.

C. Synthetic Oils

Synthetic lubricants can be advantageous over mineral oils in that they generally are more stable, have a longer life, and operate over a wider temperature range. These oils are appropriate for any application but are especially useful when units are subjected to low start-up temperatures or high operating temperatures. Use of synthetics can cause problems if they are not compatible with the seals or the conventional lubricants they replace. For continuous duty at normal ambient temperatures (-10°F to 105°F) we recommend the use of **Mobile SHC 634** which is compatible with the standard compounded oil shipped in our product and the Viton® seal material used through size 252.

3. Overfilling or Underfilling

If a speed reducer is overfilled with oil, the energy used in churning the excessive oil can result in overheating. If this occurs, shut down the drive, remove the oil level plug and allow oil to drain until oil ceases to drain from the level hole, reinstall the oil level plug and restart the drive. If the speed reducer is underfilled, the resultant friction can cause overheating and possible damage. If this occurs, fill the speed reducer to the oil level plug hole and check the gearing for excessive wear. NOTE: Oil capacity is 1¾ pints.

4. Oil Seals

Although the speed reducer uses high quality oil seals and precision ground shafts to provide a superior seal contact surface, it is possible that circumstances beyond the speed reducer's control can cause oil seal leakage (damage during shipment or installation, etc.). When replacing a shaft oil seal, using the following suggestions will help to insure leak-free operation and long seal life.

- A. When installing a new seal, cover the keyway and any other surface discontinuity with smooth tape to protect the seal lip from being damaged.
- B. A sealant should be used between the O.D. of the seal and the I.D. of the bore into which the seal is installed. The seal bore should also be free of any burrs, nicks, or scratches.
- C. Be sure that the seal is not cocked in the seal bore. The outer face of the seal should be flush with the surface into which it is mounted.

VTS512-1 GROVE GEAR REDUCER LUBRICATION AND MAINTENANCE AFTER SERIAL No. VT3

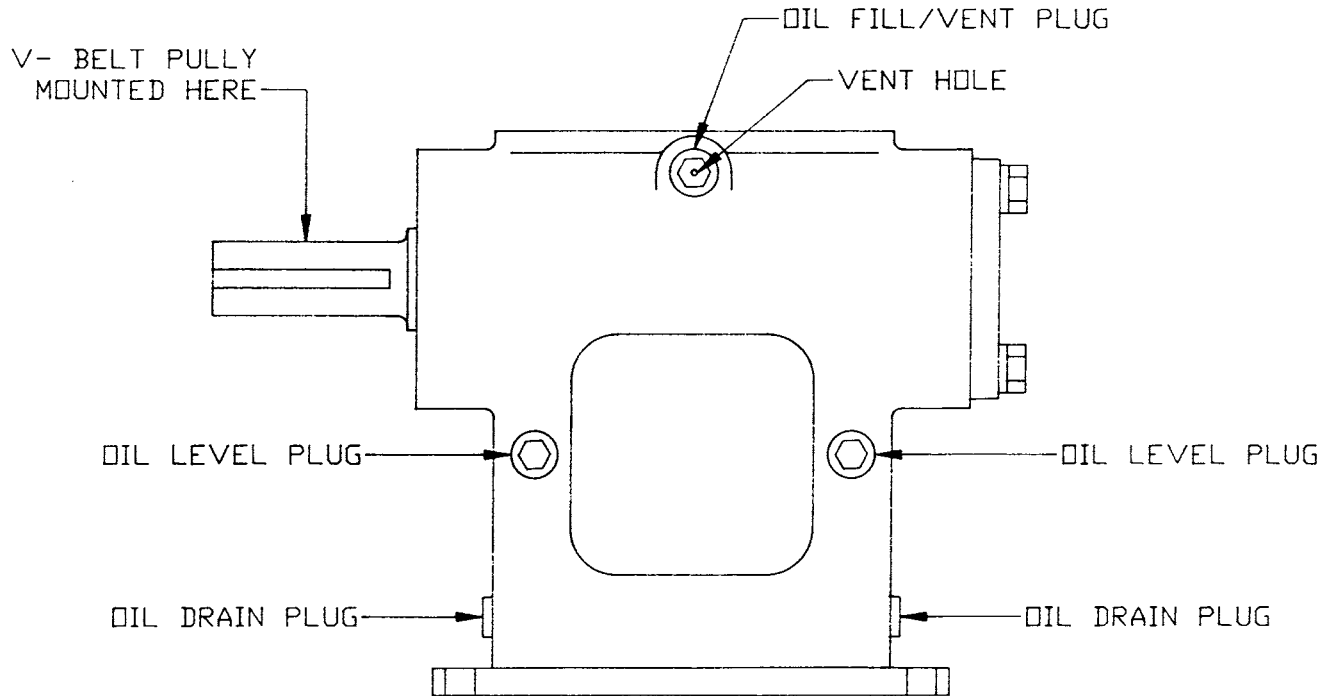

VIEW IS FROM OPPOSITE END OF DRUM

LUBRICANTS FOR VTS512-1 GROVE GEAR WORM REDUCER

The precision-made gears and bearings in Grove Gear Speed Reducers require high-grade lubricants of the proper viscosity to maintain trouble-free performance. For best results, use lubricants on the following chart for worm gear reducers.

Manufacturer	30° to 100°F Ambient Temperature AGMA Compounded No. 7	50° to 125°F Ambient Temperature AGMA Compounded No. 8
Amoco Oil Co.	Worm Gear Oil	Cylinder Oil #680
Chevron USA, Inc.	Cylinder Oil #460X	Cylinder Oil #680X
Exxon Co. USA	Cyclesstic TK-460	Cyclesstic TK-680
Gulf Oil Co.	Senate 460	Senate 680D
Mobile Oil Corp.	600 W Super Cylinder	Extra Hecla Super
Shell Oil Co.	Valvata Oil J460	Valvata Oil J680
Sun Oil Co.	Gear Oil 7C	Gear Oil 8C
Texaco	Honor Cylinder Oil	650T Cylinder Oil
Union Oil Co. of CA	Steaval A	Worm Gear Lube 140

Standard factory-installed lubricant is Mobile Oil Corp. 600 W Super Cylinder Oil (AGMA7).

Some gear lubricants contain E.P. additives that can be corrosive to gear bronze material. Avoid lubricants that are compounded with sulfur and/or chlorine.

VTS1053

PHOTOELECTRIC EYE

OPERATING INSTRUCTIONS

Starting Operation

1. Open the cover and guard of the sensor; make sure that no dirt enters the device. SEE No.1, PAGE 13
2. Select switching function:

L.ON: Light-switching if light received, output (Q) switches.

D.ON; Dark-switching if light interrupted, output (Q) switches.

WT 260-R and -S only: Light-switching: Relay 1x u, separated galvanically.

3. With following connectors only:

Connect and secure cable receptacle tension-free

Only in versions with terminal clamp area:

Loosen 1/2" PF screwed connection, remove sealing plugs.

Cable outlets downward or to the back. Pass the dead power supply line through and connect the sensor according to connection diagram.

4. Close the protective cap.

Mount the sensor using the mounting holes and align it roughly.

Connect the operating voltage to the sensor (see Type imprint).

Check scanning distance, and compare with characteristic in diagram (x = scanning distance, y = operating reserve).

Reflectance: 6% = black, 18% = gray, 90% = white (based on standard white to DIN 5033).

Aligning light reception:

Position the object. Align the WT 260 with the object. Turn the knob >SENS, <to max. When the light reception is optimal, the switching output switches into the state set in.

If no or too little light is received, realign the photoelectric proximity switch with the object and check the application conditions.

5. Setting the sensitivity (SENS): SEE No.5, PAGE 13

Remove the object. The switching output switches (Pos. A = Max).

When there is interference from the background:

Turn the knob (turning range 270°) in the direction of min. (e.g. position A). Set the rotary knob to min.

Position the object. Turn the knob in the direction of max. until the switching output switches (e.g. position B).

If position B < position A:

Select the middle setting (e.g. position C). Check overall operation. If operation is OK, setting is completed. IF operation is not OK, check the application conditions and realign.

If position A < position B:

Background influence is excessive. Check the application conditions and realign. Check sealing faces, seals, and screwed joints, then replace and screw down cover.

Maintenance

SICK photoelectric switches do not require any maintenance.

We recommend that you clean the optical interfaces and check the screw connections and plug-in connections at regular intervals.

VTS1053

Photoelectric Eye Operating Instructions

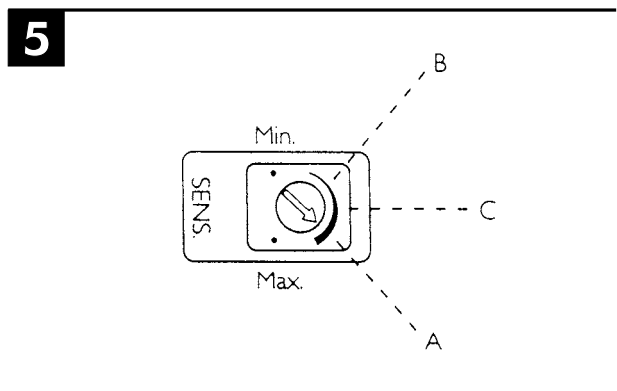
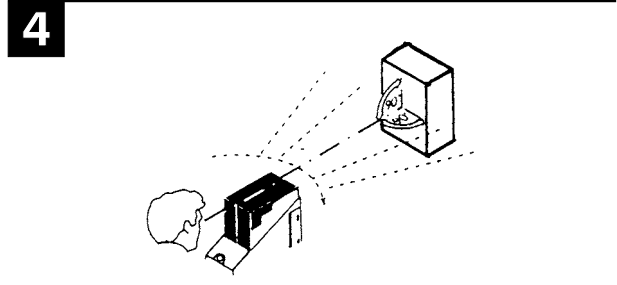
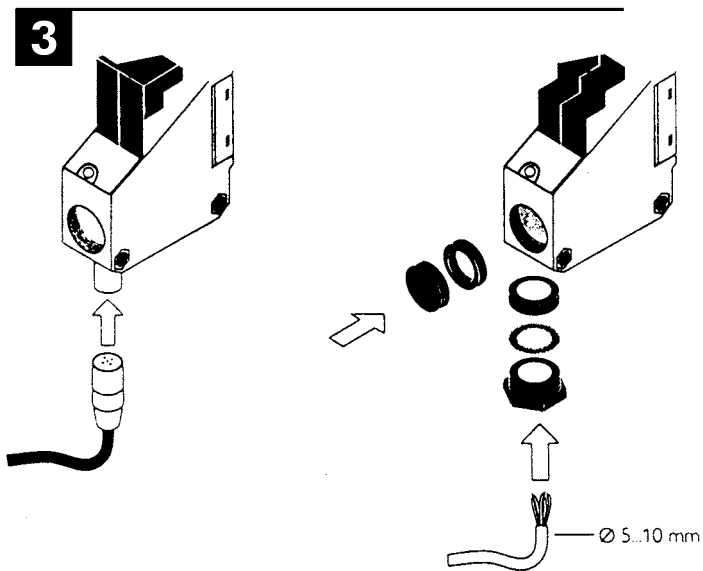
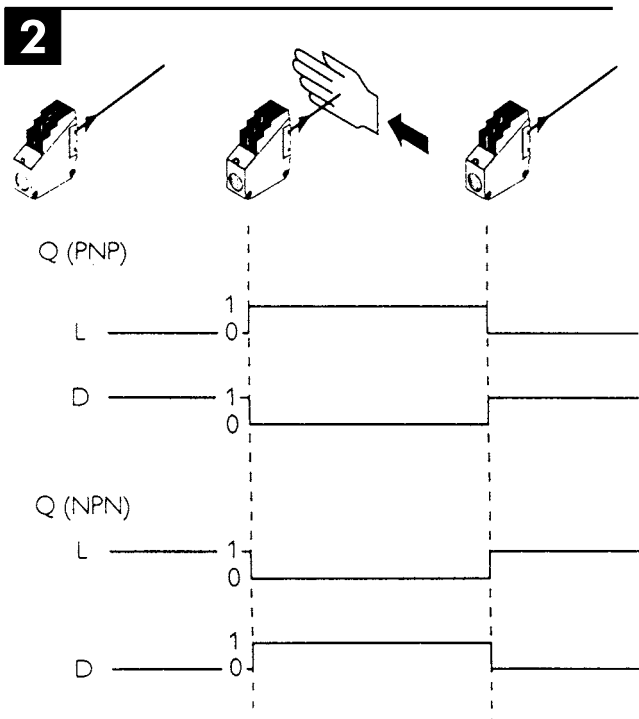
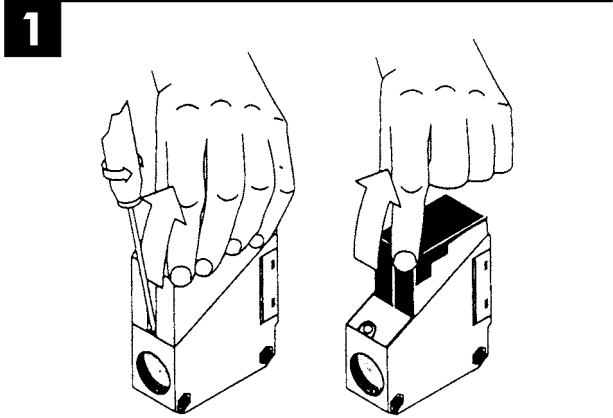

WT 260-S270

WT 260-S270

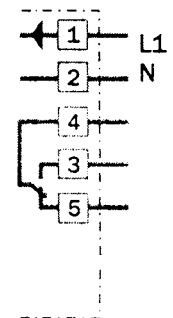
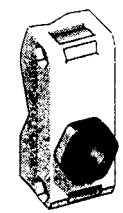
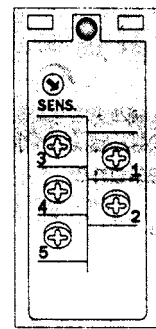

SAFETY NOTICE

This tumbler contains a photo sensor light beam as a safety barrier. If a person or object blocks the beam, the machine will STOP.

Clear the photo sensor beam & press the start button to resume operation.

VTS520-1

VTS-100 CONTROL PANEL COMPONENTS

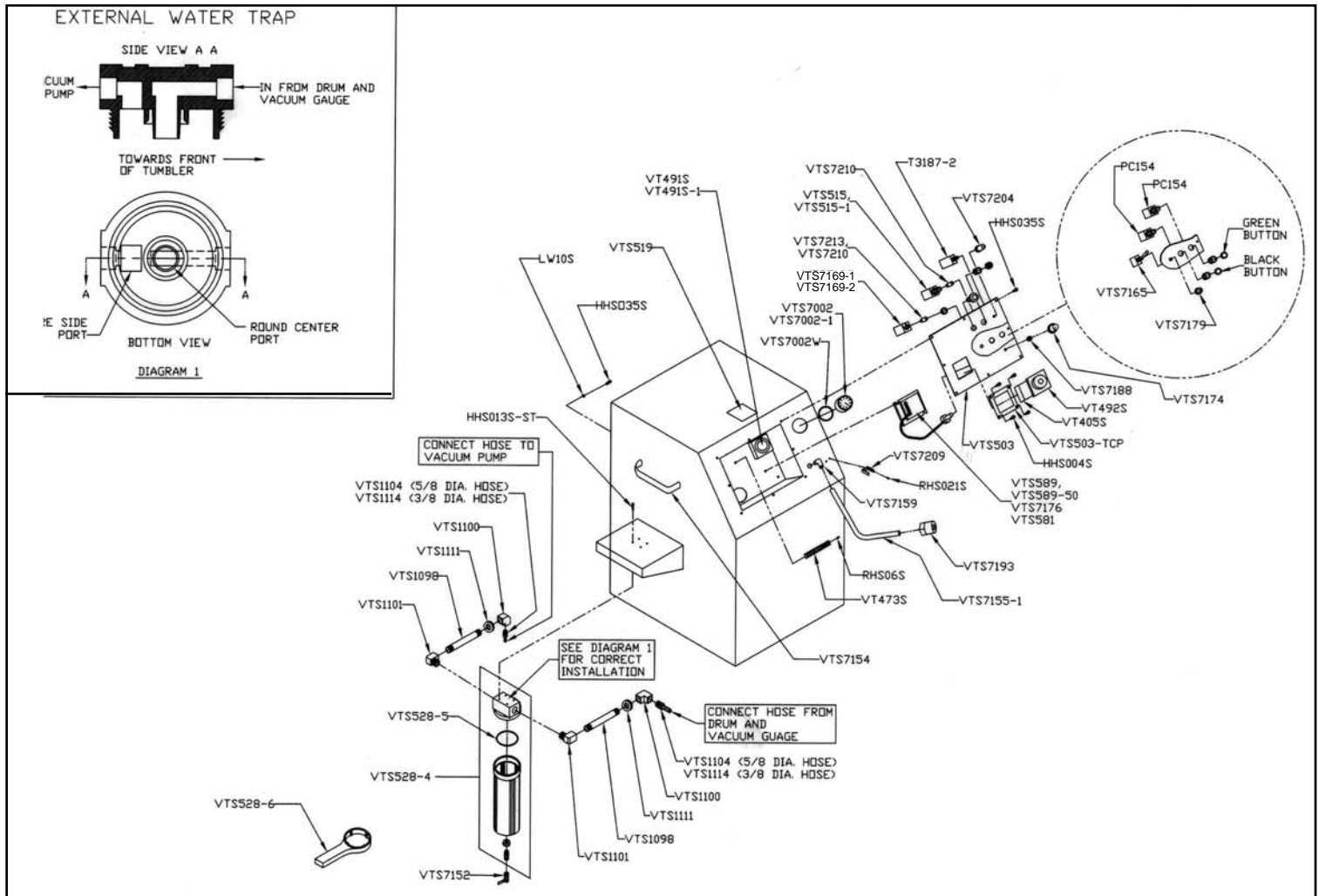

Item No.	Description
HHS004S	Hex head screw 8-32 x 1/2 SS
HHS035S	Hex head screw 1/4-20 x 1/2 S.S.
HHS013S-ST	Hex head screw 10-16 x 1/2 self tap
LW10S	Lock washer, 1/4, S.S.
PC154	Jog/on switch w/buttons (Black & Green)
RHS06S	Round head screw 6-32 x 1/2 S.S.
RHS021S	Round head screw 6-32 x 1/2 S.S.
T3187-5	Circuit breaker - 15 AMP
VT450S	Timer socket
VT491S	Ventilation fan -120V
VT491S-1	Ventilation fan -230V
VT492S	Timer 0 - 50 min interval mode
VTS1069	Label - Operating Instructions
VTS1070	Label - Warning & Control Panel
VTS376	Resistor, .015/120V
VT473S	Terminal strip - 12 circuit
VTS503	Control panel
VTS503-TCP	Timer conversion plate
VT491S	Ventilation fan - 120V
VT491S-1	Ventilation fan - 230V
VT492S	Timer 0-50 min. interval mode
VTS515	Timer indicator light - 120V
VTS515-1	Timer indicator light - 220V
VTS519	Timer sequence label
VTS528-4	External trap - clear bowl
VTS528-5	O-ring external trap
VTS528-6	Wrench external trap
VTS581	Fuse - 8 Amp - SLO-BLO, MDL
VTS589	Power supply 120VAC - 90VDC - .015 Res.
VTS589-50	Power supply 220VAC - 90VDC - .015 Res.
VTS1098	Nipple 6 x 1/2 NPT - brass

Item No.	Description
VTS1100	Elbo 90 deg. x 1/2 NPT - brass
VTS1101	Street elbow 90 deg. x 1/2 NPT - brass
VTS1104	Male hose barb 3/8 x 1/2 NPT - brass
VTS1111	Grommet x 3/8" ID
VTS1114	Male hose barb 3/8 x 1/2 NPT - brass
VTS7002	Vacuum gauge - Glycerin filled
VTS7002-1	U-Clamp kit
VTS7002W	Spacer washer
VTS7132	Aluminum washer
VTS7152	Ball valve - S.S.
VTS7154	Handle
VTS7155-1	Hose with 3/8 crimped fitting
VTS7159	90 DEG elbow 3/8 FPT x 3/8 FPT S.S.
VTS7164	Toggle switch On/Off w/boot
VTS7165	Toggle switch On/Off
VTS7169-1	Emergency stop switch - 120V
VTS7169-2	Emergency stop switch - 220V
VTS7171	Timer label
VTS7172	Vacuum gauge label
VTS7173	Potentiometer
VTS7174	Potentiometer knob
VTS7176	Fuse - 10 Amp, ABS series
VTS7179	Toggle switch half boot
VTS7180	Legend plate - Emergency Stop
VTS7188	Potentiometer boot
VTS7193-B	Quick coupling S.S.
VTS7204	Circuit breaker boot
VTS7205	Legend plate - Press to Reset
VTS7209	Spring clip holder
VTS7210	Bulb, 6.3VDC - 50HZ
VTS7213	Bulb, 120V - 60HZ

CONTROL PANEL - REAR VIEW

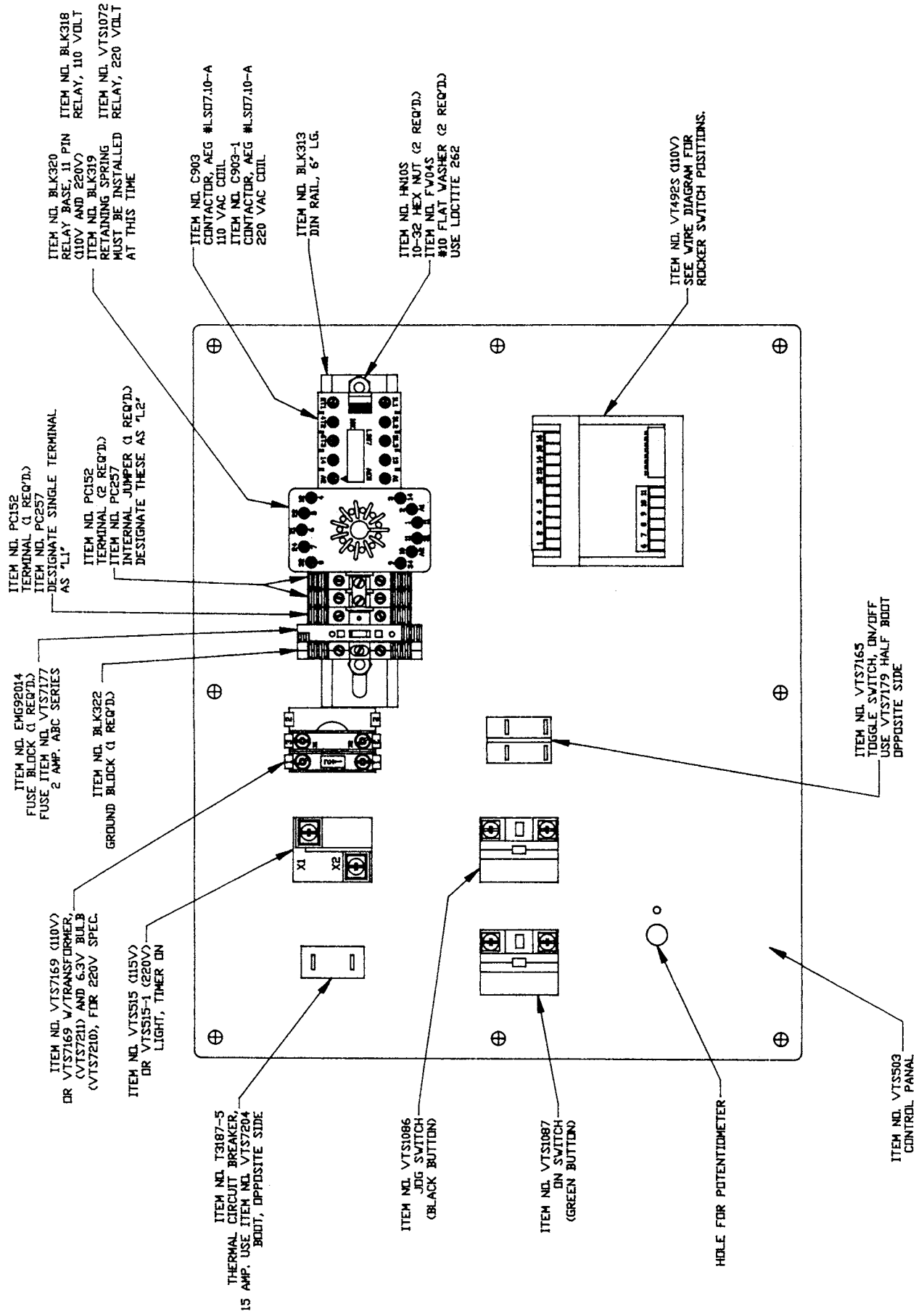

DRUM ASSEMBLY

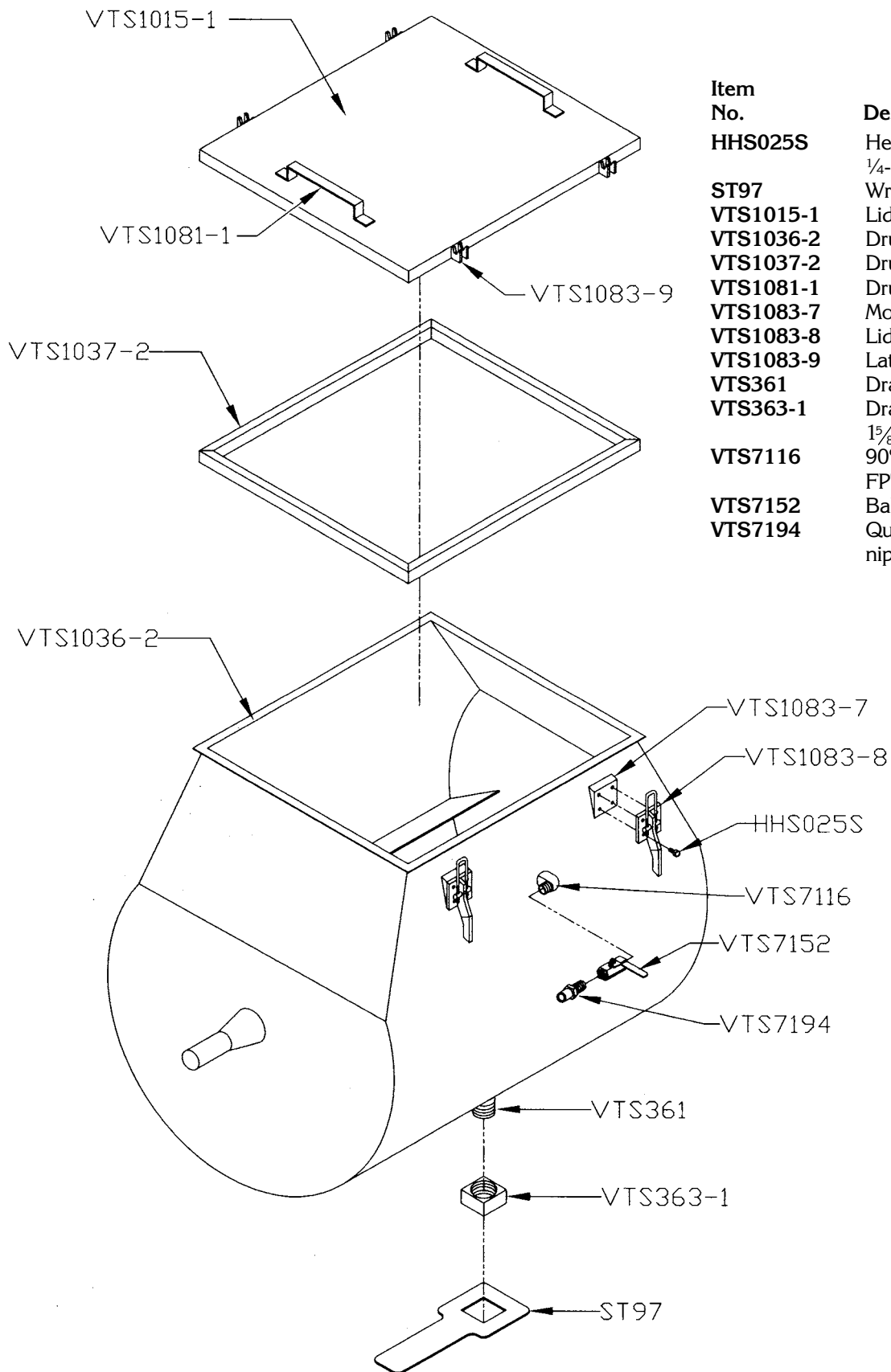

Item No.	Description
HHS025S	Hex head screw, 1/4-20 x 1/2 SS
ST97	Wrench, 2 1/4, drain cap
VTS1015-1	Lid weldment
VTS1036-2	Drum weldment
VTS1037-2	Drum gasket
VTS1081-1	Drum cover handle
VTS1083-7	Mounting block
VTS1083-8	Lid latch
VTS1083-9	Latch keeper plate
VTS361	Drain plug
VTS363-1	Drain cap, delrin, 1 5/8-12 thread
VTS7116	90° elbow 3/8 MPT x 3/8 FPT, SS
VTS7152	Ball valve, SS
VTS7194	Quick coupling nipple, SS

FRAME ASSEMBLY AND COMPONENTS

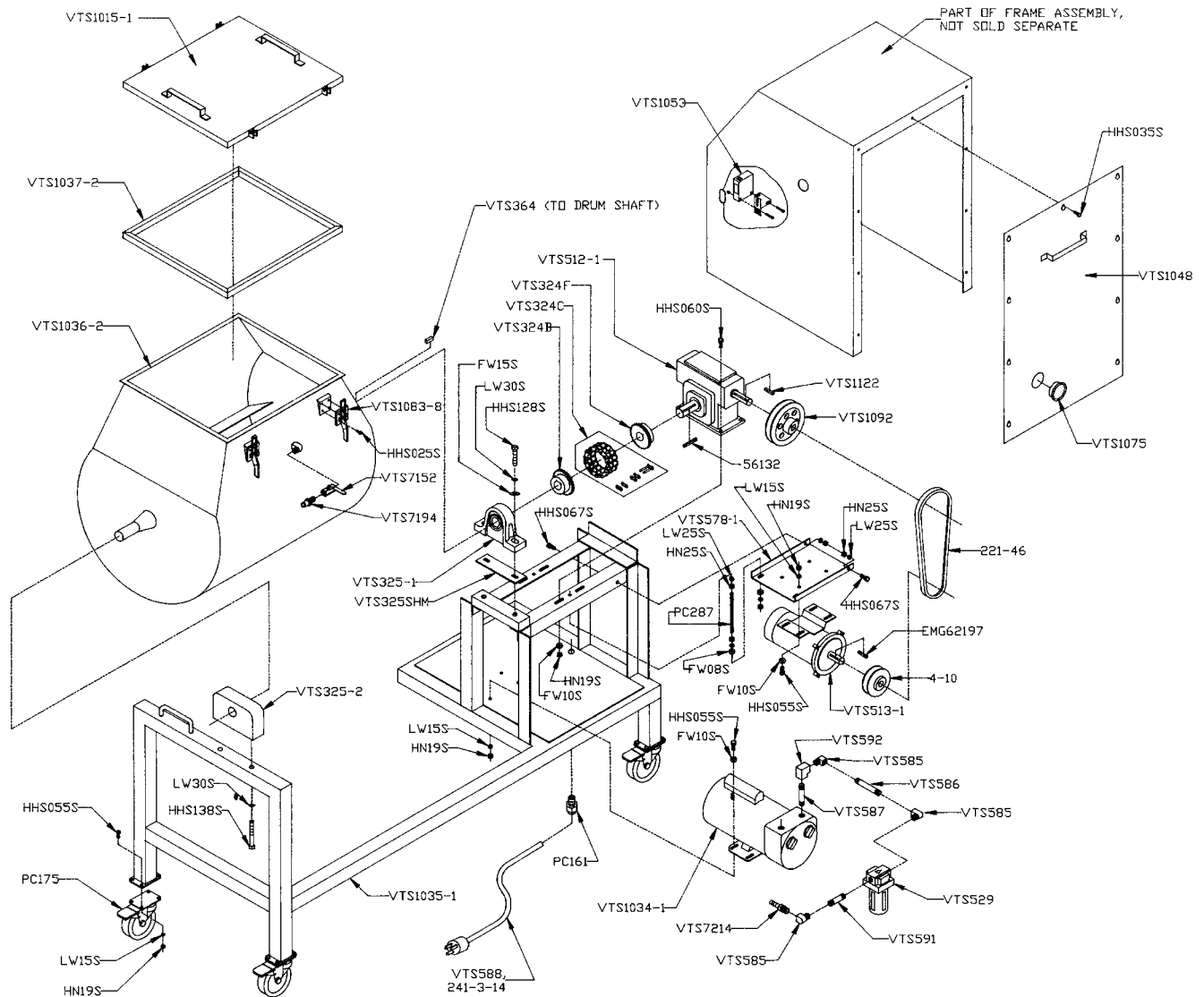

Item No.	Description
221-46	V-belt, 46 inch
4-10	Pulley 4 x 5/8 bore
56132	Pulley key 1/4 x 1/4 x 1 1/2 long S.S.
FW08S	3/8 flat washer, 1 1/32 x 1 x 1/16 S.S.
FW10S	5/16 flat washer, 1 1/32 x 3/4 x 1/16 S.S.
FW15S	1/2 flat washer, 1/2 x 1 1/4 x 1/16 S.S.
HHS025S	Hex head screw 1/4-20 x 1/2 S.S.
HHS035S	Hex head screw 1/4 - 20 x 5/8 SS
HHS055S	Hex head screw, 5/16-18 x 3/4, S.S.
HHS060S	Hex head screw, 3/16-18 x 1, S.S.
HHS067S	Hex head screw, 3/8-16 x 3/4, S.S.
HHS128S	Hex head screw, 1/2-13 x 1 3/4, S.S.
HHS138S	Hex head screw, 1/2-13 x 4, S.S.
HN19S	Hex nut 3/8-18 S.S.
HN25S	Hex nut 3/8-16 heavy S.S.
HN43S	Hex nut 1/2-13 heavy S.S.
LW15S	Lock washer 5/16 S.S.
LW25S	Lock washer 3/8 heavy S.S.
LW30S	Lock washer 1/2 S.S.
PC161	Strain relief fitting 3/8 dia.
PC175	Caster w/swivel locking
PC287	Motor adjustment threaded rod
VTS1015-1	Lid weldment
VTS1034-1	Vacuum pump - 3/4 HP
VTS1035-1	Frame assembly (NSS)
VTS1036-2	Drum weldment
VTS1037-2	Drum gasket
VTS1048	Rear door

Item No.	Description
VTS1053	Photoelectric eye
VTS1075	Sight window - 2" dia.
VTS1083-8	Lid latch
VTS1092	Pulley - aluminum 9 x 3/4 bore
VTS1122	Key 3/16 x 3/16 x 1 3/8 SS
VTS324B	Roller chain coupling hub 1 1/2 bore
VTS324C	Chain assembly
VTS324F	Roller chain coupling hub 1 1/8 bore
VTS325-1A	Pillow block bearing & shim
VTS325-2	Pillow block - Delrin
VTS325SHM	Pillow block shim
VTS364	Key 3/8 x 3/8 x 1 1/8 SS
VTS512-1	Gear reducer 60 to 1 (Grove Gear) after serial no. VT3
VTS513-1	Gear motor 90VDC x 3/4HP
VTS529	Vacuum pump filter
VTS529-1	Filter element
VTS578-1	Motor base plate, adjustable (Grove Gear)
VTS585	Elbow, 90 degree Street, 3/8" brass
VTS586	Nipple, 3 inch, 3/8 pipe, brass
VTS587	Nipple, 2 inch, 3/8 pipe, brass
VTS588	Power cord, 14-3 sjow, 12 ft. w/plug
VTS591	Nipple 3/8 MPT x 1 1/8 - brass
VTS592	Elbow 90° x 3/8 MPT - brass
VTS7152	Ball valve - SS
VTS7194	Quick coupling nipple - SS
VTS7214	Hose barb 3/8 MPT x 3/8 x .95 lg. brass

VACUUM HOSES & FITTINGS

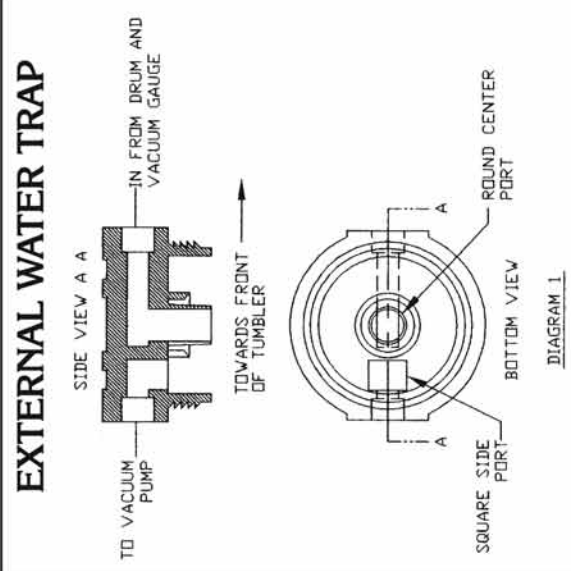
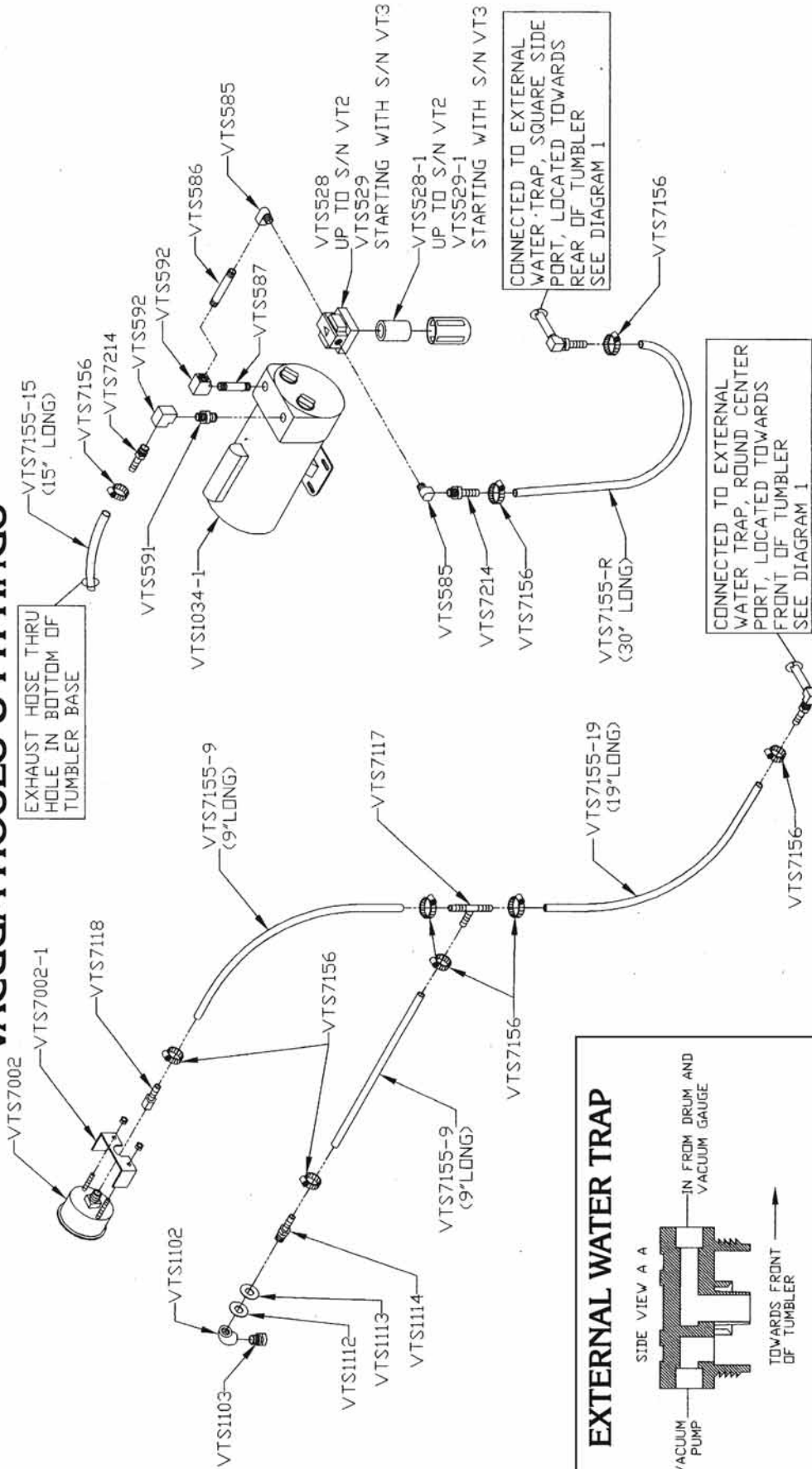

Item No.	Description	Item No.	Description
VTS1034-1	Vacuum pump - 3/4 HP	VTS7002	Vacuum gauge
VTS1103	Reducer bushing 1/2 x 3/8 - S.S.	VTS7117	Tee barb - plastic 3/8 x 3/8 x 3/8
VTS1112	Shim washer .125 Thk x .875 ID x 1.375 OD	VTS7118	Straight barb - brass 1/4 FPT x 3/8
VTS1113	Shim washer .093 Thk x .875 ID x 1.375 OD	VTS7132	Washer - aluminum 1 1/16 O.D. x 1 1/16 I.D.
VTS1114	Male hose barb 3/8 hose x 1/2 NPT	VTS7155-9	Vacuum hose - 9 inch
VTS529-1	Filter (06F21BC)	VTS7155-10	Vacuum hose - 10 inch
VTS585	Filter element	VTS7155-15	Vacuum hose - 15 inch - Nylobrade
VTS586	Elbow, 90 degree street, 3/8", brass	VTS7155-19	Vacuum hose - 19 inch
VTS587	Nipple, 3 inch, 3/8 pipe, brass	VTS7156	Hose clamp
VTS591	Nipple, 2 inch, 3/8 pipe, brass	VTS7159	90 degree elbow - S.S., 3/8 FPT x 3/8 FPT
VTS592	Nipple 1 1/2 x 3/8 pipe - brass	VTS7214	Hose barb - brass 3/8 MPT x 3/8
	Elbo - 90° x 3/8 pipe - brass		

VACUUM HOSES & FITTINGS

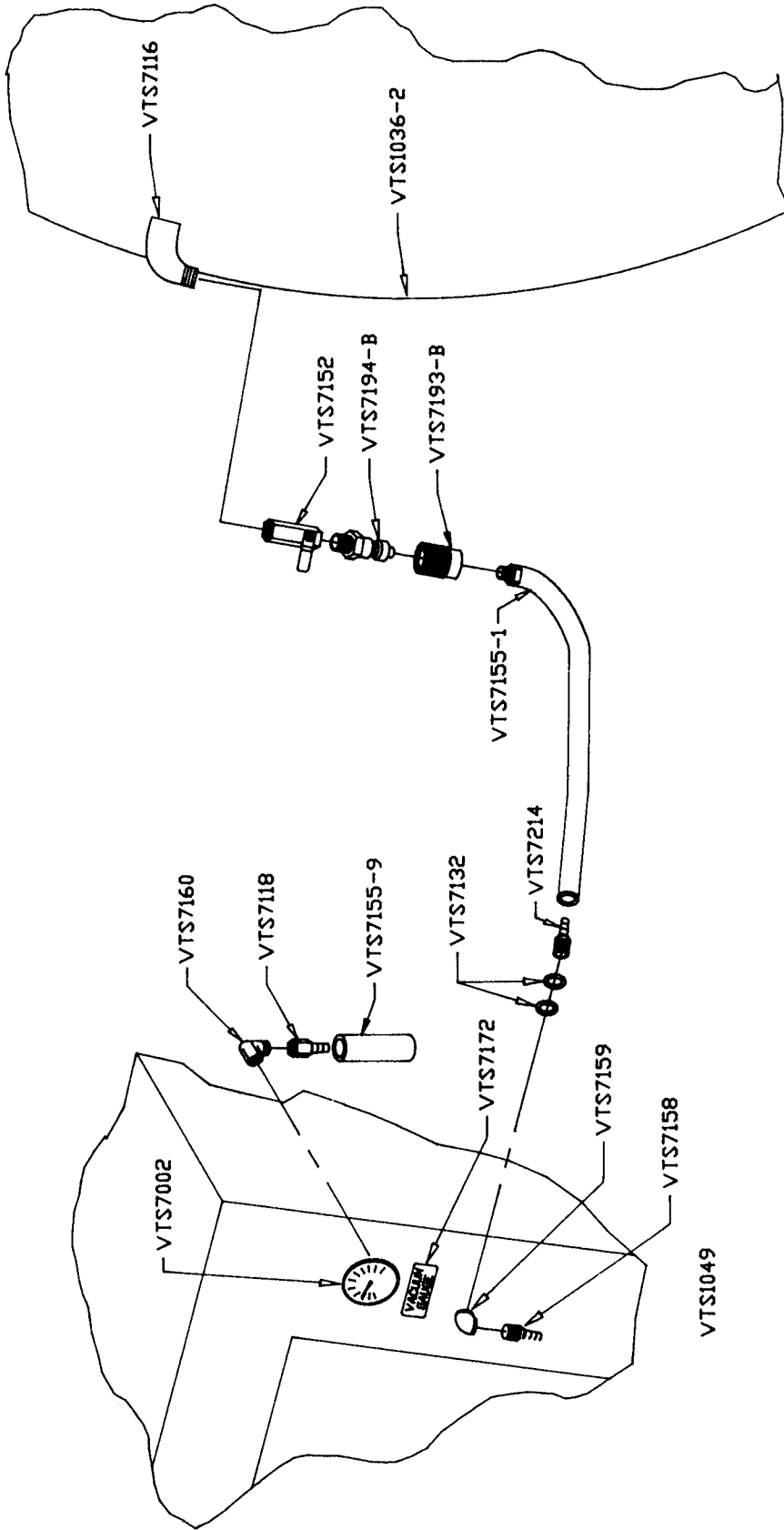

Item No.	Description	Item No.	Description
VTS1036-2	Drum weldment	VTS7155-9	Vacuum hose - 9" nylobrade
VTS1049	Control box cover	VTS7158	Hose barb $\frac{3}{8}$ " MPT x $\frac{3}{8}$ " x $1\frac{3}{8}$ " barb lg
VTS7002	Vacuum gauge - glycerin filled	VTS7159	90 degree elbow $\frac{3}{8}$ " FPT x $\frac{3}{8}$ " FPT - SS
VTS7116	90° elbow $\frac{3}{8}$ " MPT x $\frac{3}{8}$ " FPT - SS	VTS7160	90° street $\frac{1}{4}$ " MPT x $\frac{1}{4}$ " FPT - brass
VTS7118	Straight barb $\frac{1}{4}$ " FPT x $\frac{3}{8}$ " - brass	VTS7172	Vacuum gauge label
VTS7132	Washer - aluminum	VTS7193-B	Quick coupler BST-3
VTS7152	$1\frac{3}{16}$ " O.D. x $1\frac{1}{16}$ " I.D. x $\frac{1}{16}$ " TK	VTS7194-B	Nipple - quick coupler BST-N3M
VTS7155-1	Ball valve - SS	VTS7214	Hose barb $\frac{3}{8}$ " MPT x 1 barb - brass
	Hose w/ $\frac{3}{8}$ " crimped fitting - 38" long		

COMPONENT COVER AND REAR DOOR

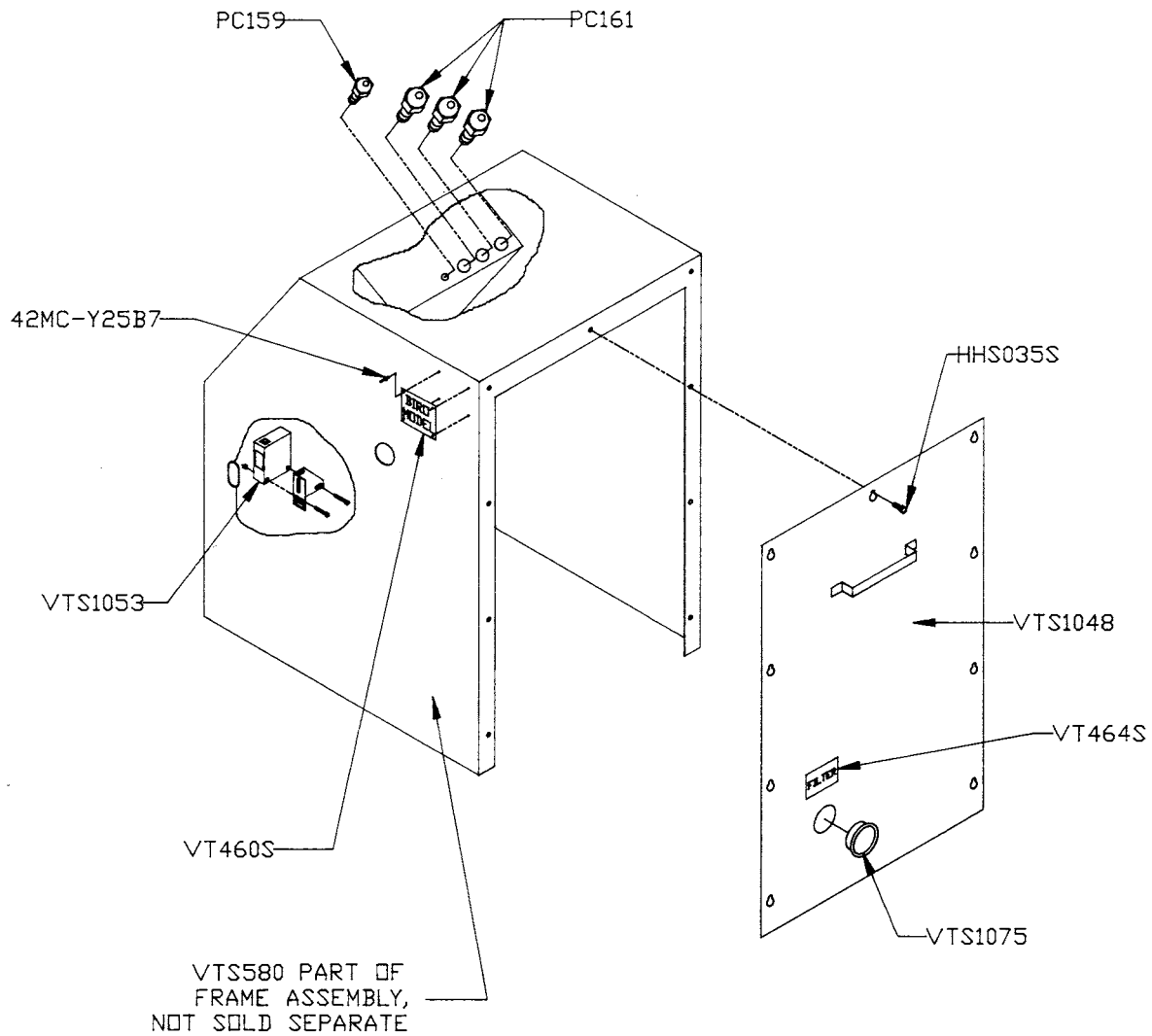

Item No.	Description
42MC-Y25B7	Pop rivet – aluminum $\frac{1}{8} \times \frac{1}{4}$
HHS035S	Hex head screw $\frac{1}{4}$ -20 $\times \frac{5}{8}$ S.S.
PC159	Strain relief fitting – $\frac{1}{2}$ dia.
PC161	Strain relief fitting $\frac{7}{8}$ dia
VTS1048	Rear door
VTS1053	Photoelectric eye w/bracket only.
VTS1053-1	Photoelectric eye assembly complete - 4 wires used w/VT492S timer.
VTS1053-2	Photoelectric eye assembly complete - 5 wires used w/VTS511 timer.

Item No.	Description
VTS1075	Sight window – 2" dia.
VT460S	Model and S/N plate
VT464S	Filter label
VT481S	Locking knob
VTS580	Component cover (NSS)
VTS7197	Filter access panel

120 VAC WIRING DIAGRAM

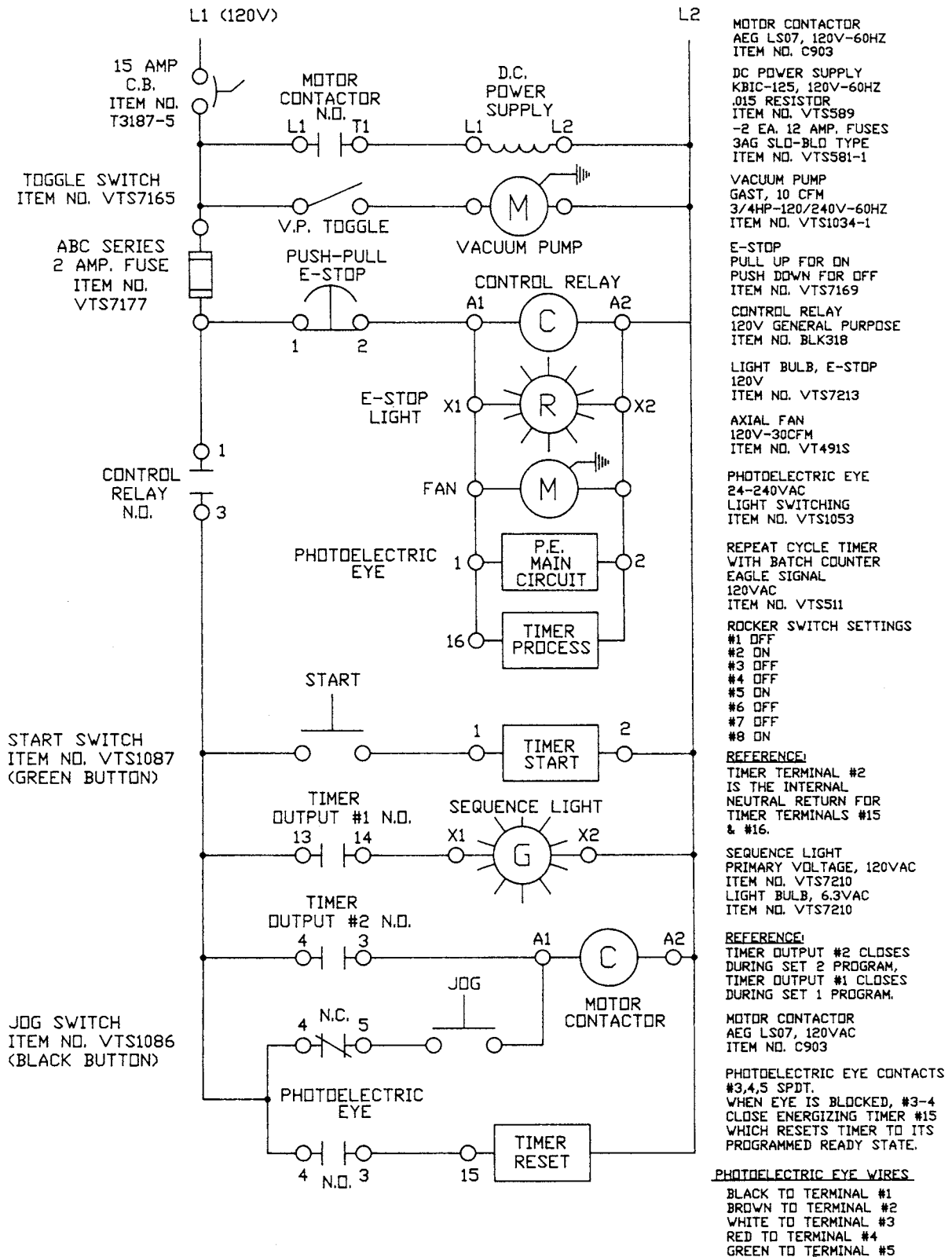

220 VAC WIRING DIAGRAM

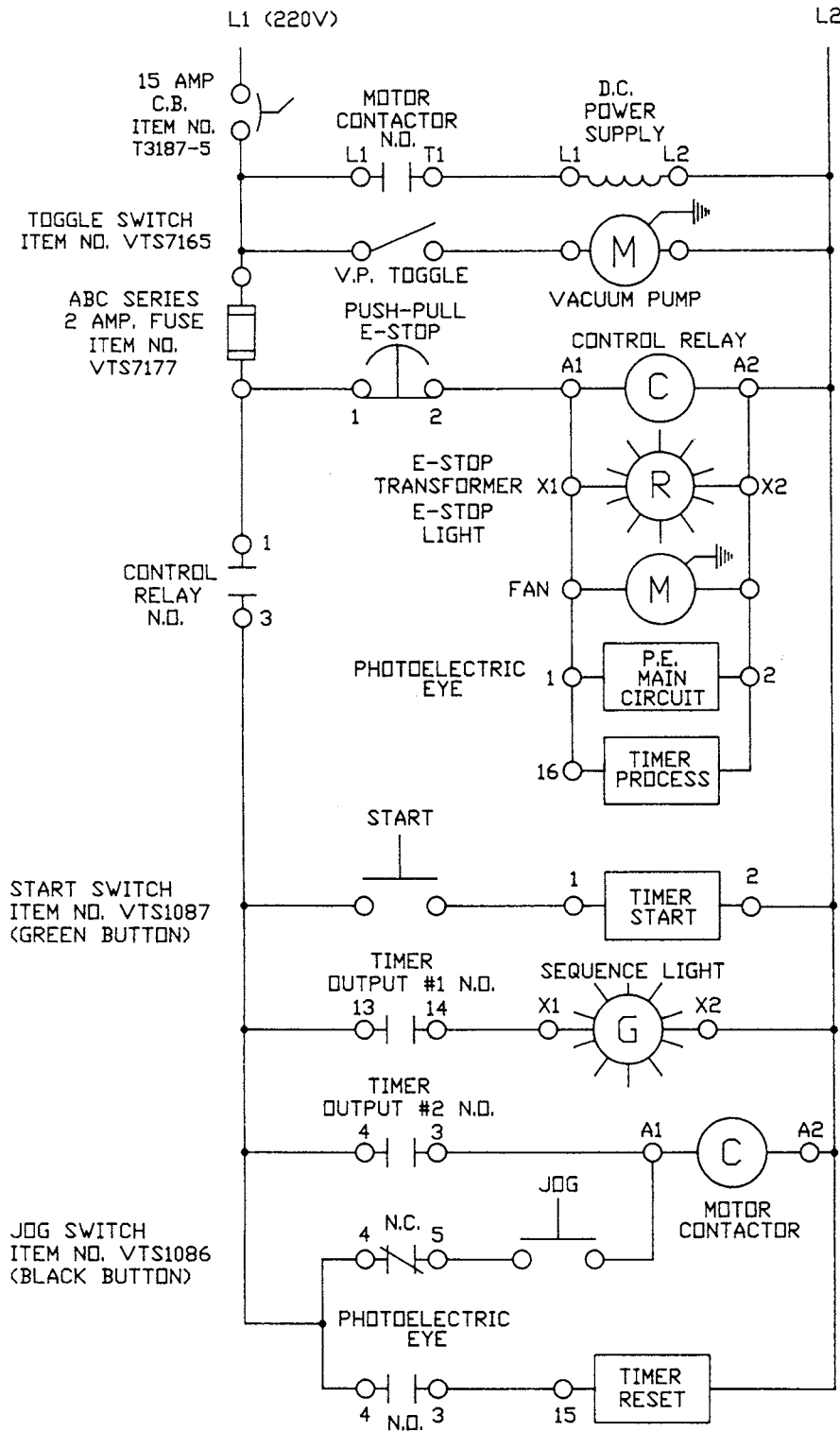

- MOTOR CONTACTOR
AEG LS07, 220V-60HZ
ITEM NO. C903-1
- DC POWER SUPPLY
KBIC-240, 240V-60HZ
.015 RESISTOR
ITEM NO. VTS589-50
-2 EA. 12 AMP. FUSES
3AG SLD-BLD TYPE
ITEM NO. VTS581-1
- VACUUM PUMP
GAST, 10 CFM
3/4HP-120/240V-60HZ
ITEM NO. VTS1034-1
- E-STOP
PULL UP FOR ON
PUSH DOWN FOR OFF
ITEM NO. VTS7169
- CONTROL RELAY
220V GENERAL PURPOSE
ITEM NO. VTS1072
- TRANSFORMER, E-STOP
220V PRI./6.3V SEC.
ITEM NO. VTS7211
- LIGHT BULB, E-STOP
6.3V
ITEM NO. VTS7210
- AXIAL FAN
220V-30CFM
ITEM NO. VT491S-1
- PHOTOELECTRIC EYE
24-240VAC
LIGHT SWITCHING
ITEM NO. VTS1053
- REPEAT CYCLE TIMER
WITH BATCH COUNTER
EAGLE SIGNAL
220VAC
ITEM NO. VTSS11-50
- ROCKER SWITCH SETTINGS
#1 OFF
#2 ON
#3 OFF
#4 OFF
#5 ON
#6 OFF
#7 OFF
#8 ON
- REFERENCE:
TIMER TERMINAL #2
IS THE INTERNAL
NEUTRAL RETURN FOR
TIMER TERMINALS #15
& #16.
- SEQUENCE LIGHT
PRIMARY VOLTAGE, 220VAC
ITEM NO. VTSS15-1
LIGHT BULB, 6.3VAC
ITEM NO. VTS7210
- REFERENCE:
TIMER OUTPUT #2 CLOSES
DURING SET 2 PROGRAM,
TIMER OUTPUT #1 CLOSES
DURING SET 1 PROGRAM.
- MOTOR CONTACTOR
AEG LS07, 220VAC
ITEM NO. C903-1
- PHOTOELECTRIC EYE CONTACTS
#3,4,5 SPDT.
WHEN EYE IS BLOCKED, #3-4
CLOSE ENERGIZING TIMER #15
WHICH RESETS TIMER TO ITS
PROGRAMMED READY STATE.
- PHOTOELECTRIC EYE WIRES
BLACK TO TERMINAL #1
BROWN TO TERMINAL #2
WHITE TO TERMINAL #3
RED TO TERMINAL #4
GREEN TO TERMINAL #5

RECOMMENDED VTS-100 SPARE PARTS

VTS1037-2	Drum cover gasket
VTS363-1	Drain cap
VTS529	Vacuum pump filter
VTS1083-8	Latches
VT492S	Timer
VTS1053	Photoelectric eye
VTS529-1	Filter elements

– NOTES –

VTS - 100 VACUUM TUMBLER

PREVENTATIVE MAINTAINANCE

GENERAL:

VACUUM COMPONENTS, ELECTRICAL COMPONENTS:

Check drum cover gasket for cuts, tears, damage. Replace if damaged.

Install gasket and lid onto vacuum drum.

Check for proper fit and correct latch tension to achieve a good seal. Adjust latches if needed.

Check electrical components for damage.

Remove power from machine. Replace damaged components.

Check power cord for wear or damage.

Remove cord from power source. Replace power cord.

Check photoelectric eye safety switch for proper operation.

Machine must stop when eye is activated.

Do not use machine if photoelectric eye safety switch does not work correctly. Repair or replace.

Check external water trap for liquid/marinate.

If liquid is above maximum level, inspect complete vacuum system and vacuum pump.

Disassemble, clean, and dry all components including vacuum pump. Reassemble.

Check vacuum hoses and fittings for wear or damage. Replace if damaged.

VACUUM PUMP CAUTION: During operation, water/marinate must not enter the vacuum pump. Immediately clean and dry all vacuum components.

LUBRICATION: **MOTOR, VACUUM PUMP, DRUM BEARINGS, CHAIN COUPLING, GEAR REDUCER:**

The drive motor has sealed bearings.

The vacuum pump motor has sealed bearings.

The vacuum pump has carbon vanes and does not require lubrication.

CAUTION: PUMP MUST NOT INGEST ANY WATER OR MARINATE.

The drum bearings should be greased every 40 hours.

The chain coupling should be greased 160 hours.

Grease Manufacturer: SHELL

Grease Type: CASSIDA EPS 2 OR Equivalent.

The gear reducer oil should be changed at the end of 250 hours.

Subsequent oil changes should be done every 2500 hours or 6 months, whichever comes first.

Oil Manufacturer: MOBILE OIL CORP.

Oil Type: 600W SUPER CYLINDER Oil or Equivalent.

Oil Capacity: 1-3/4 Ounces

OPERATOR'S SIGNATURE PAGE

WARNING
READ AND UNDERSTAND THIS ENTIRE
MANUAL BEFORE SIGNING BELOW

MY SIGNATURE ATTESTS THAT I HAVE COMPLETELY READ AND UNDERSTAND THIS MANUAL. I REALIZE THAT THIS MACHINE, IF OPERATED CARELESSLY, CAN CAUSE SERIOUS INJURY TO MYSELF AND OTHERS.

NAME (PRINT)	SIGNATURE	SUPERVISOR'S INITIALS	DATE

LIMITED WARRANTY:

WARRANTY: The Biro Manufacturing Company warrants that the BIRO Vacuum Tumbler will be free from defects in material and workmanship under normal use and with recommended service. BIRO will replace defective parts, which are covered by this limited warranty, provided that the defective parts are authorized for return, shipping charges prepaid, to a designated factory for inspection and/or testing.

DURATION OF WARRANTY: The warranty period for all parts covered by this limited warranty is one (1) year from installation/demonstration as advised on the returned warranty registration card, or eighteen (18) months starting from original factory shipping date, whichever occurs first, except as noted below.

PARTS NOT COVERED BY WARRANTY: The following are **not** covered by this limited warranty: VTS529 vacuum pump inlet filter, VTS1037-2 drum lid gasket. This limited warranty does not apply to machines sold as used, rebuilt, modified, or altered from the original construction in which the machine was shipped from the factory. Water contaminated electrical systems and VTS1034-1 vacuum pump, are not covered under this limited warranty. BIRO is not responsible for electrical connection of equipment, adjustments to switch components or any other electrical requirements, which must be performed only by a certified electrician. BIRO is not responsible for service charges or labor required to replace any part covered by this limited warranty or for any damages resulting from misuse, abuse, lack of proper or recommended service. Failure to follow drum loading procedure will result in liquid collecting inside the vacuum pump which voids this warranty.

EXCLUSION OF WARRANTIES AND LIMITATION OF REMEDIES: BIRO gives no warranties other than those expressly stated in this limited warranty. THE IMPLIED WARRANTY OF MERCHANTABILITY, THE IMPLIED WARRANTY OF FITNESS FOR PROCESSING OF FOOD PRODUCTS, AND ALL OTHER IMPLIED WARRANTIES ARE SPECIFICALLY EXCLUDED. BIRO IS NOT LIABLE FOR CONSEQUENTIAL OR INCIDENTAL DAMAGES, EXPENSES, OR LOSSES. THE REMEDIES PROVIDED IN THIS BIRO LIMITED WARRANTY ARE PURCHASER'S SOLE AND EXCLUSIVE REMEDIES AGAINST BIRO.

REGISTRATION CARDS: You must sign, date and complete warranty registration card supplied with each machine. The warranty registration card must be returned to The Biro Manufacturing Company for proper registration. If no warranty card is returned to BIRO, the warranty period will begin from the date the machine was originally shipped from the factory.

HOW TO GET SERVICE:

1. Contact the agency from whom you purchased the machine.
2. Consult the yellow pages of the phone directory for the nearest authorized dealer.
3. Or call BIRO Service Department (419) 798-4451, who will put you in contact with the nearest service agency.

THE BIRO MANUFACTURING COMPANY

1114 Main Street
Marblehead, Ohio 43440-2099
Ph. 419-798-4451
Fax 419-798-9106
E-mail: service@birosaw.com
Web: <http://www.birosaw.com>