



# **B350MV**

## **VERTICAL FOOD SLICER**

### **INSTALLATION, USE, MAINTENANCE & PARTS MANUAL**

MARBLEHEAD, OHIO 43440-2099 U.S.A.  
Ph. 419-798-4451 Fax 419-798-9106  
[sales@birosaw.com](mailto:sales@birosaw.com) [service@birosaw.com](mailto:service@birosaw.com)  
<http://www.birosaw.com>

Revised 6-13-11



WWW.BIROSAW.COM  
THE BIRO MANUFACTURING COMPANY, 1114 W. MAIN ST.,  
MARBLEHEAD, OH 43440-2099 U.S.A.

Model: **B 350 MV** \_\_\_\_\_

s/n: \_\_\_\_\_



Compliant to NSF/ANSI Standard 8: Commercial powered food preparation equipment.



This machine was designed and built to slice food in compliance to the norms of the 89/392 - 89/336 Directive and following amendments CE 91/368 - 93/44 - 93/68 CE, EN 1974 directive 89/109.

\*Materials and objects destined to the food products contact directive (89/109 CEE) and subsequent modification (2002/72/CEE)

\*EN 60204-1 Machines electrical equipments

\*EN 60335-2-64 Particular requisition for kitchen machines

\*UNI EN 1974 Machines for food industries – Slicing Machines  
-Security and hygiene features

## **CONTENTS**

### **FOREWORD**

SCOPE OF THIS MANUAL

### **GENERAL INFORMATION**

GENERAL SAFETY REGULATIONS

MANUFACTURER'S WARRANTY AND LIABILITY

PLATES – CONFORMITY MARKS

ENVIRONMENTAL CONDITIONS OF USE

### **PACKING**

OPENING THE BOX

### **TECHNICAL DESCRIPTION AND PROPOSED CONDITIONS OF USE**

GENERAL DESCRIPTION

MECHANICAL AND ELECTRICAL SAFETY DEVICES

WARNING: RESIDUAL RISKS

DIMENSIONS

MAIN TECHNICAL DATA

SUPPLIED LITERATURE AND ACCESSORIES

PRODUCTS THAT CAN BE SLICED

PRODUCTS THAT MUST NOT BE SLICED:

MAIN COMPONENTS

### **MACHINE COMMISSIONING AND FUNCTION TESTS**

INSTALLING THE MACHINE

ELECTRICAL CONNECTION

CONTROLS

FUNCTIONING TEST AND BLADE ROTATION DIRECTION

### **USING THE MACHINE**

LOADING THE PRODUCT ON THE TRAY AND SLICING

### **CLEANING THE SLICER B350M (1)**

GENERAL

DISASSEMBLING THE MACHINE FOR CLEANING

### **CLEANING THE SLICER B350M (2)**

REASSEMBLING THE MACHINE

### **MAINTENANCE**

GENERAL

BLADE SHARPENING

SHARPENING INSTRUCTIONS B350M

### **LUBRICATION**

### **TROUBLESHOOTING AND REMEDIES**

### **DISMANTLING THE SLICER**

### **ELECTRICAL DIAGRAM**

### **B350M RECOMMENDED SPARE PARTS**

## **FOREWORD**

### **SCOPE OF THIS MANUAL**

This manual contains all the necessary information to install, use and service the gravity slicers for food (please see models in paragraph “Technical Description”). The scope of this document, hereinafter the “manual”, is to permit users, and especially end users, to take all the cautions and provisions possible for using this machine safely and for a long period of time.

### **GENERAL SAFETY REGULATIONS**

The slicer must only be used by trained personnel. Furthermore, they must have read this manual carefully.

#### *In particular, please comply to the following instructions*

- Install the machine according to the instructions contained in the “Installation” section.
- Do not remove the transparent protections, do not modify nor exclude the mechanical and electrical safety devices.
- Do not use the machine with improvised connections, or provisional or non - insulated cables.
- Check the power cable and gland plate on the machine body regularly, and when necessary have them replaced by a qualified personnel.
- In case of abnormalities, defective operation, incorrect movement, unusual noise, etc stop the machine immediately.
- Before cleaning or servicing, disconnect the machine.
- Always use non-slip gloves during cleaning or maintenance.
- Lay or remove the goods to be sliced on the sliding plate only when the carriage is completely pushed back and the thickness control knob is positioned to 0.
- To move the carriage tray when slicing, use the handle or the product grip handle.
- For extraordinary maintenance (to replace the sharpening stones, the blade, or others) please contact the manufacturer or qualified and duly trained personnel.
- Avoid running the slicer with no product on it.
- The slicer is equipped with a ventilated motor.
- **WARRANTY: 1 YEAR** except for the electrical parts

## MANUFACTURER'S WARRANTY AND LIABILITY

The manufacturer's warranty covering the functioning of the machine and their compliance to the service for which they have been designed, depends on the proper application of the instructions contained in this manual.

*The Manufacturer assumes no liability either direct or indirect for:*

- Failure to comply with the instructions contained in this manual;
- Use of the machine by personnel who has not read or fully understood the content of this manual
- Use not complying to the specific norms currently applicable in the country of installation
- Improper use
- Use of non original accessories or spare parts.
- Exceptional events.

## PLATES – CONFORMITY MARKS

The machine has been constructed in compliance with the European Directive 89/392 and subsequent amendments. All the parts used in the machine meet the terms of the Directive and the CE marks have been applied to substantiate this compliance.

The plate carrying the Manufacturer's data, the machine data and the CE mark are applied onto the machine base under the blade guard tie-rod knob.

*In case of wear or damage, the user must replace it.*

<b>BIRO</b> ®	THE BIRO MANUFACTURING COMPANY MARBLEHEAD, OH 43440-2099 EM: sales@brosaw.com www.brosaw.com
Mod.: B350M B350MV	
Volt: 115V 60Hz 1Ph	
S/N:	<input type="text"/>

## ENVIRONMENTAL CONDITIONS OF USE

- |                     |                       |
|---------------------|-----------------------|
| - Temperature       | from -5 °C to + 40 °C |
| - Relative humidity | max 95%               |

## PACKING

### OPENING THE BOX

On receipt, check packaging integrity, otherwise inform the forwarding agent or the area agent immediately.

*To unpack the machine, proceed as follows:*

- Open the box and remove the manual of use and maintenance, then proceed according to the instructions found in it;
- Lift the machine still wrapped in a transparent polythene sheet.
- Now check the box contents and make sure it corresponds to what is shown on the external label.

### **WARNING:**

*The packaging components (cardboard, polythene, and others) are classified as normal solid urban waste and can therefore be disposed of without difficulty. In any case, for suitable recycling, we suggest disposing of the products separately (differentiated waste) according to the current norms.*

**DO NOT DISCARD ANY PACKAGING MATERIALS  
IN THE ENVIRONMENT!**

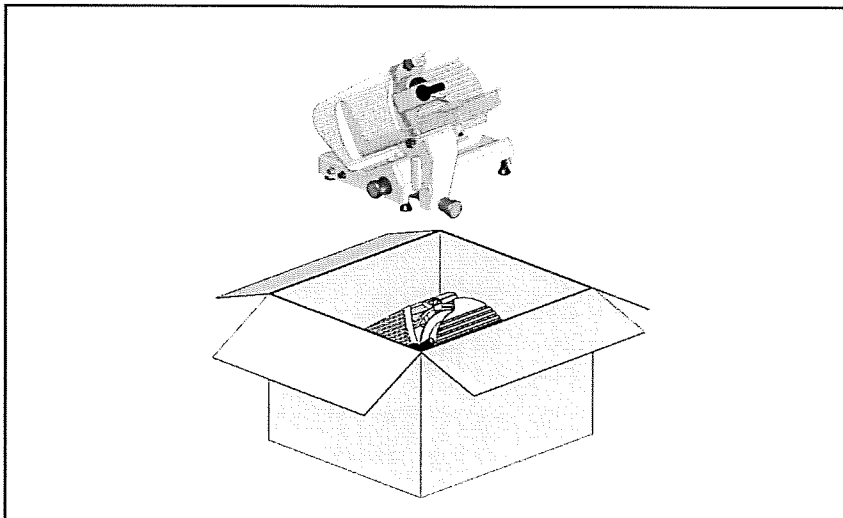

## **TECHNICAL DESCRIPTION AND PROPOSED CONDITIONS OF USE**

### **GENERAL DESCRIPTION**

The machine is essentially made of a base supporting, a circular blade mounted in a tilted position. This blade is driven by an electrical motor to slice food. The machine is equipped with a carriage holding, a product tray and sliding on tracks mounted under the base top, parallel to the blade.

Slice thickness is adjusted by a gauge plate mounted in front of the blade. This plate is moved transversally with respect to the blade up to the desired slice thickness.

All the machine components are made of polished and anodized oxidized aluminium alloy, of stainless steel and food grade plastic material.

The blade is driven by an electrical motor, the transmission by a grooved belt. The machine is started and stopped by control buttons provided with auxiliary circuit preventing accidental restarts after an outage.

Some of the machine models have a user-friendly and safe built-in blade sharpener.

### **MECHANICAL AND ELECTRICAL SAFETY DEVICES**

*The following mechanical safety devices are installed:*

- aluminium hands protection on the carriage
- ring covering the edge of the blade

*The following electrical safety devices are installed:*

- Start/stop button system requiring a voluntary restart of the machine in the case of an outage or interruption of the power supply.

### **WARNING: RESIDUAL RISKS**

**Not with standing all the possible cautions taken during the design and the construction of the machine, residual risks (cutting) still exist during use or during cleaning or maintenance. Therefore be careful and PAY THE UTMOST ATTENTION to what you are doing.**

**DO NOT use the machine if you are not in perfect psychological and physical conditions. DO NOT ALLOW anyone near the machine when it is in use. ALWAYS wear gloves that can resist cuts or tears when cleaning, lubricating or sharpening the blade.**

**Slice only the products mentioned as sliceable. NEVER try to slice products that have been mentioned as non sliceable.**

## DIMENSIONS / MAIN TECHNICAL DATA

### BIRO MOD. B350MV

#### VERTICAL SLICER

<b>MODEL</b>	<b>B350MV</b>		<b>MODEL</b>
motor kw	0,35		motor kw
blade diam inch	14"	350	blade diam mm
rpm	200		rpm
slice thickness inch	0 – 1"	0 – 18	slice thickness mm
max cut inch ○	10"	255	max cut mm ○
max cut inch □	12" x 10"	300 x 255	max cut mm □
<b>Overall dimensions inc</b>			<b>Overall dimensions mm</b>
length	24,5"	620	length
width	28,5"	720	width
height	21,5"	540	height
gross weight-Lbs	99,2	45	gross weight - kg
net weight-Lbs	79	35	net weight - kg
box dimensions inch	28" x 32,5" x 26,5"	710 x 830 x 670	box dimensions mm.



## **SUPPLIED LITERATURE AND ACCESSORIES**

If not otherwise defined at the moment of order, the machines are supplied together with the following:

- Instructions manual for installation, use and maintenance.
- ETL NSF CSA
- EU conformity declaration

## **PRODUCTS THAT CAN BE SLICED**

- All types of cold cuts (raw, cooked, smoked);
- Meat without bone (raw or cooked, at a temperature not less than + 3 °C);
- Cheese cuts (obviously types that can be sliced such as gruyere, mozzarella, etc.).

## **PRODUCTS THAT MUST NOT BE SLICED:**

1. Frozen or deep-frozen food;
2. Food containing bones (meat or fish);
3. Any other non-food product

## MAIN COMPONENTS B 350 MV

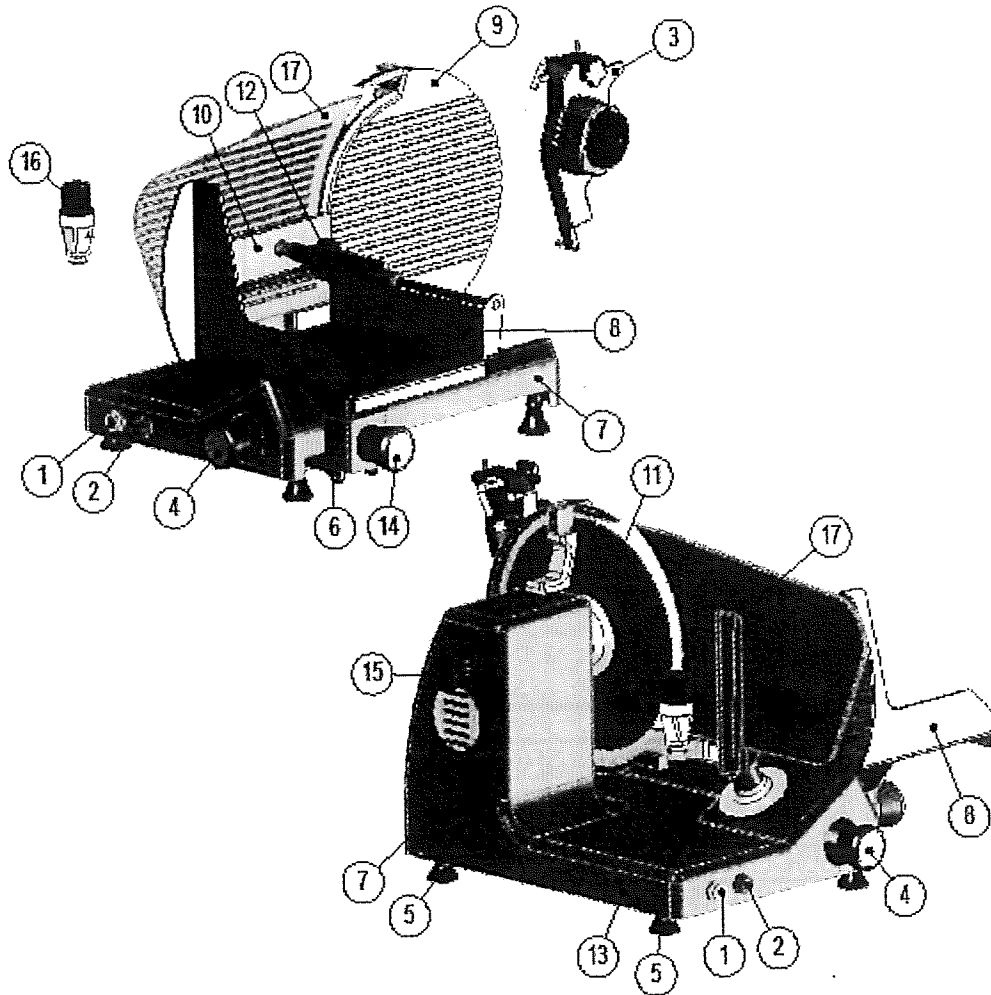

CODE	DESCRIPTION
1	STARTUP BUTTON(GREEN)
2	STOP BUTTON (RED)
3	SHARPENER
4	SLICE THICKNESS CONTROL KNOB
5	ADJUSTABLE FOOT
6	CARRIAGE TRAY SUPPORT
7	BASE
8	PRODUCT TRAY
9	BLADE PLATE
10	PRODUCT GRIP
11	BLADE
12	PRODUCT GRIP HANDLE
13	MANUFACTURED IDENTIFICATION
14	CARRIAGE TRAY KNOB
15	BLADE PLATE TIE-ROD
16	SUPPLY CORD
17	GAUGE PLATE

## **MACHINE COMMISSIONING AND FUNCTION TESTS**

### **INSTALLING THE MACHINE**

Position the machine on a well leveled, smooth and dry top suitably dimensioned to withstand the machine weight.

### **ELECTRICAL CONNECTION**

Install the machine near a USA compliant outlet derived from a system meeting the current norms.

**The user is responsible for** ascertaining that the electrical system is suitably dimensioned and functions correctly (supply line, outlet, distribution panel, differential protecting breaker, grounding).

**Before carrying out the connection** ascertain that the mains characteristics correspond to those indicated on the machine plate.

### **COMMANDS**

#### **START AND STOP BUTTONS**

- Press the green button (1) to start running the blade.
- The light turns on to indicate that the machine works correctly.
- Press the red button to stop the blade (2).

**Slice thickness** can be adjusted by turning the graduated knob (3) anti clockwise.

**Thickness adjustment range:** see paragraph “Technical description and conditions of use”.

#### **FUNCTIONING TEST AND BLADE ROTATION DIRECTION**

Start the machine and check whether the light is on; make sure that the blade rotates in the direction indicated by the arrow (anti clockwise if you look at the machine from the blade plate side).

- Ascertain that the carriage and the pusher slide correctly;
- Ascertain that the gauge plate works and adjust thickness to desired value.

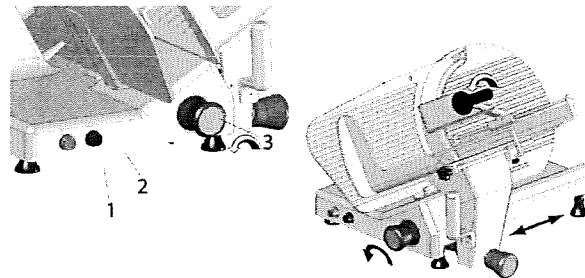

## USING THE MACHINE

### LOADING THE PRODUCT ON THE TRAY AND SLICING

- Ascertain that the adjustable knob is correctly positioned to '0'.
- Draw back the carriage completely (towards the operator) to loading position.
- Lift the pusher by pulling it away by 10 cm from the blade and put it in the rest position.
- Lay the product to be sliced against the gauge plate on the operator side.
- Secure the pusher by exerting slight pressure.
- Adjust the thickness gauge plate. Start the blade by pressing on the green button.
- Grip the handle affixed onto the plate and start the forward and backward cutting movement. The product travels towards the gauge plate by gravity.
- When the product weight or its dimensions do not provide a satisfactory cut by effect of the gravity, use the pusher handle.
- When finished, return the adjustable knob to '0' and pull the carriage back.
- Stop the blade by pressing the red button.

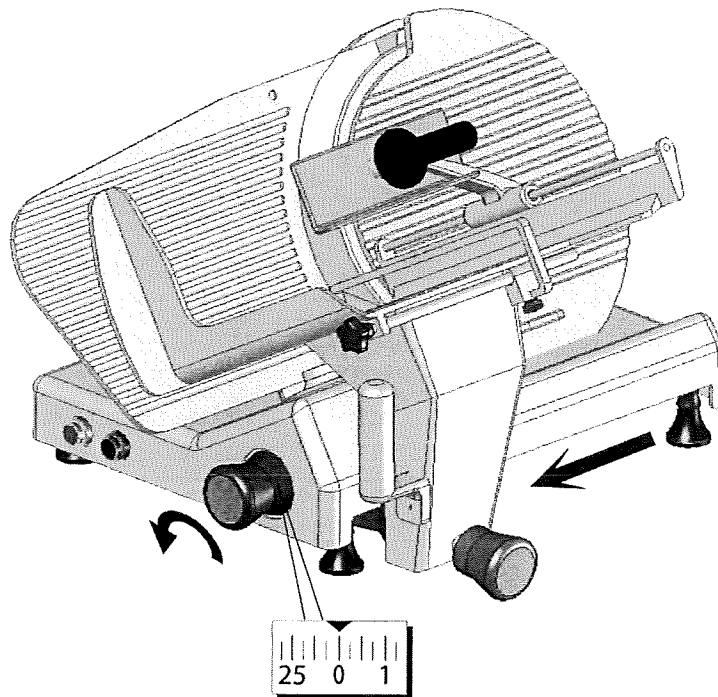

## CLEANING THE SLICER B350M – B350MV (1)

### GENERAL

The machine must always be carefully cleaned at least once a day, and more often if necessary.

Always use protective gloves.

### DISASSEMBLING THE MACHINE FOR CLEANING

- Disconnect the plug from the mains;
- Turn the gauge plate to '0';
- Remove the various components as described in the following paragraphs:
- Unscrew (anticlockwise) the blade guard rod (ref. 1);
- Remove the blade guard using for this operation only cover handle (ref. 2).
- Remove the slice guard.

To clean the machine body and the blade use only a damp cloth with water and biodegradable soapy detergent having 7-8 pH and at a temperature not below + 30°C.

### WARNING:

Use scratch-proof and non-slip gloves to carry out the following operations. Proceed carefully and pay attention to what you are doing.

**Danger of cutting!**

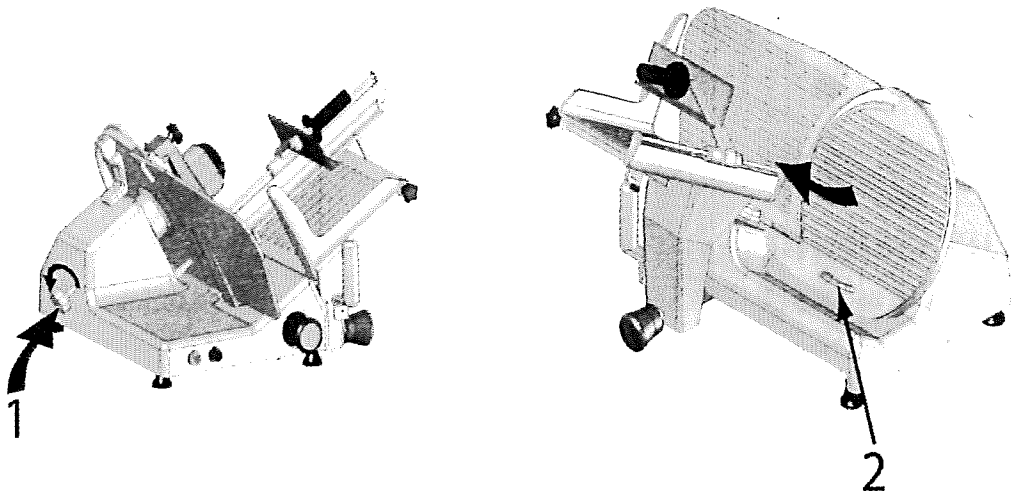

## CLEANING THE SLICER B 350 MV (2:UPSETTING PLATE)

- Stop the machine, rotate the adjustable knob to regulate the gauge plate and position it on 0 (1)
- Return the carriage to the operators side (2)
- Turn the knob (3) anti clockwise, until loose, the carriage will then drop back for cleaning(4).

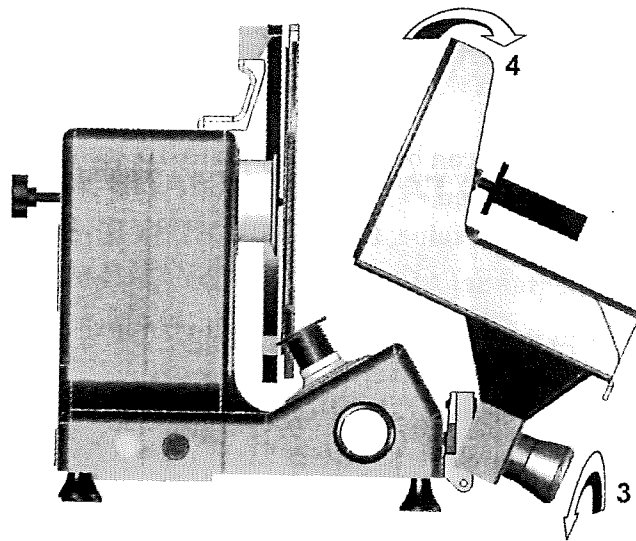
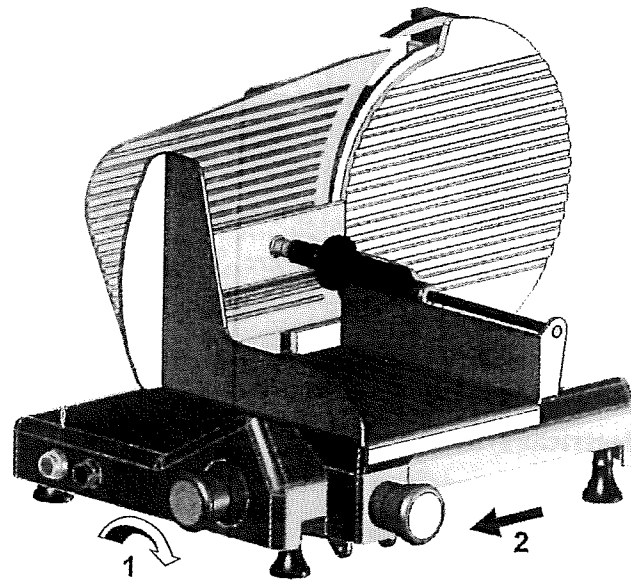

## REASSEMBLING THE MACHINE

Proceed as indicated for the previous operations but in reverse order.

## MAINTENANCE

### GENERAL

*The operator is allowed to perform the following maintenance operations:*

- Blade sharpening: regularly (intervals and duration obviously depend on the use of the machine, time of use and type of product sliced);
- Lubrication of carriage sliding guides: once a week.
- Lubrication of product grip sliding bar: once a week.
- Checking the power supply wire conditions and the gland plate: from time to time.

### WARNING

*Maintenance must always be carried out when the machine is disconnected from the mains.*

*Always make sure that the adjustable knob is in the "O" position*

*The following maintenance operations are to be entrusted only to personnel authorised by the manufacturer:*

- Replacing the blade;
- Replacing the sharpening stones;
- Replacing the motor transmission belt;
- Replacing electrical system components under the machine frame;
- Repairing structural parts, repairing the components under the frame.

### BLADE SHARPENING

Before proceeding, carefully clean the machine as explained in the previous paragraphs:

### WARNING

Sharpening can be done only up to 0,5 inches of the blade diameter value.

**Beyond this value, the BLADE MUST BE REPLACED ONLY by personnel AUTHORISED BY THE MANUFACTURER.**

## SHARPENING

Version with **NOT INTEGRATED** sharpener

To sharpen the blade periodically and proceed as per the following instructions:

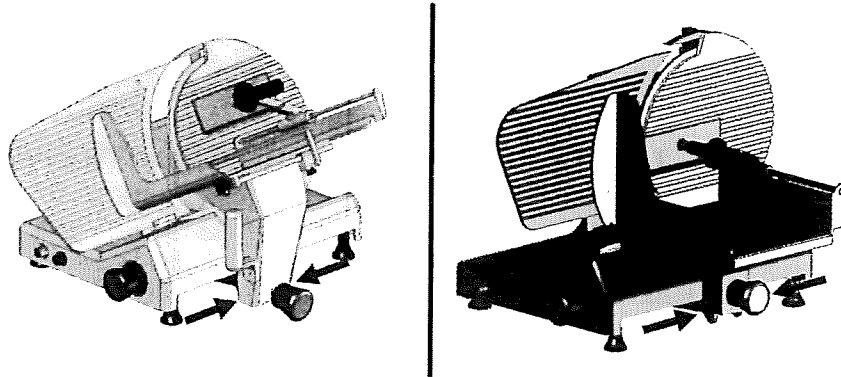

**1) CLEAN THE BLADE**

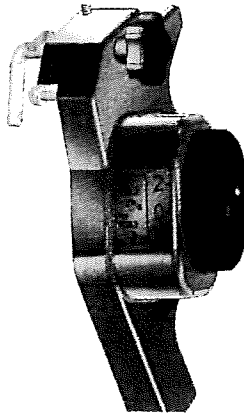

**2) ASSURE THE SHARPENER IS AT ZERO POSITION**

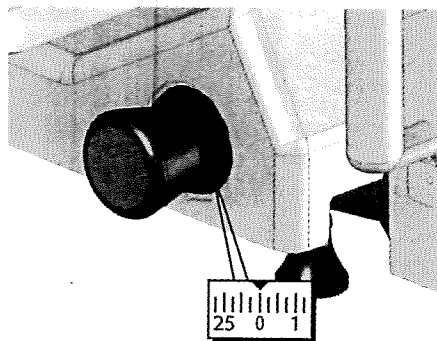

**3) B 350 M : MOVE THICKNESS REGULATOR TO THE 25mm**  
**3) B 350 MV: MOVE THICKNESS REGULATOR TO THE 20mm**



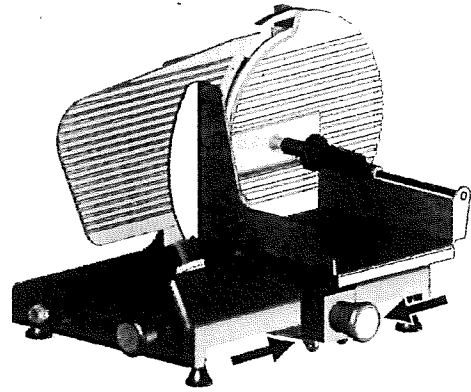
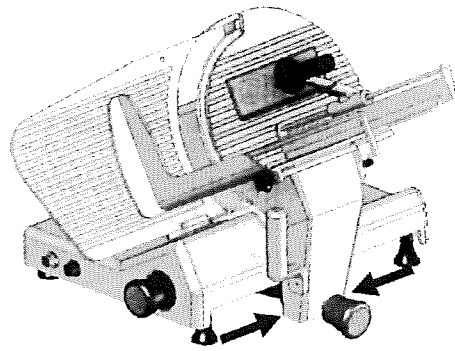

4) THIS OPENED THE BLADE TO THE DESIRED POSITION READY FOR POSITIONING THE SHARPENER. MEAT PLATE POSITIONED IN THE MIDDLE.

5) THE SMALL RECESS ON THE GAUGE PLATE IS FOR THE POSITIONING OF THE SHARPENING MECHANISM.

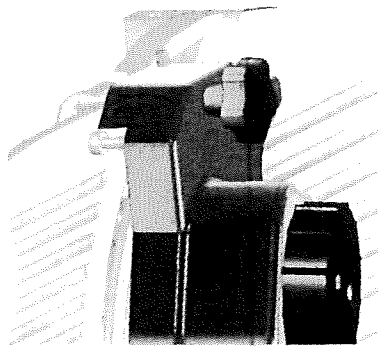
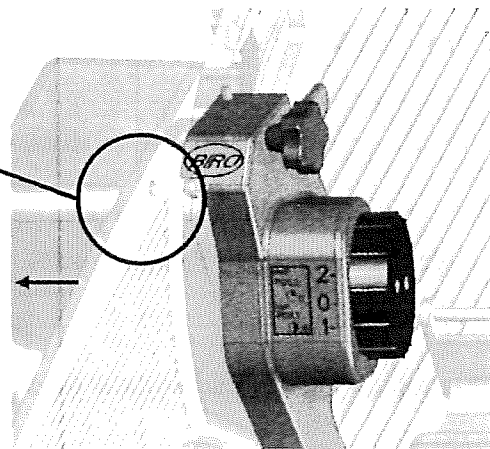
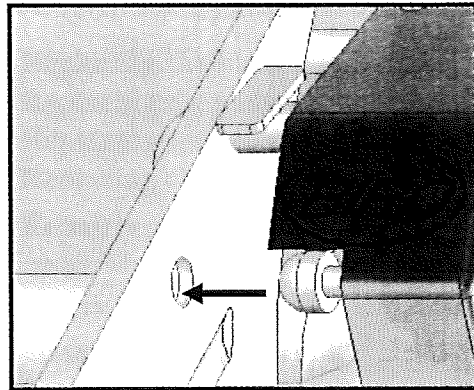

PLACE SHARPENING MECHANISM ONTO PLATE.

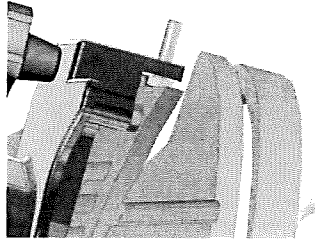

**6) VERIFY POSITION**

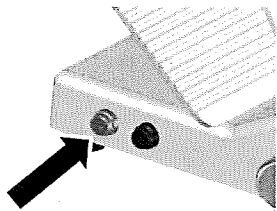

**7) START BLADE ROTATING.**

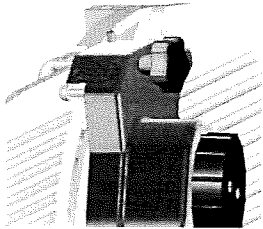

**8) TURN DIAL TO POSITION 1. THIS WILL SHARPEN THE REAR OF THE BLADE.  
RUN FOR 30 SECONDS, TURN DIAL TO POSITION 2 FOR 15 SECONDS. THIS WILL TAKE THE BURR OF THE FRONT SURFACE OF BLADE**

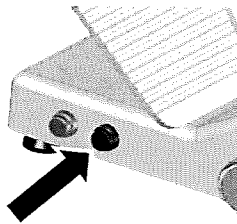

**9) STOP MACHINE.  
REMOVE SHARPENER AND CLEAN BLADE BEFORE USING THE MACHINE AGAIN.**

## LUBRICATION

### Carriage sliding guides pusher (once a week)

*Use only the oil provided, otherwise use food grade lubricant spray.  
**DO NOT USE VEGETABLE OILS.***

- Spread a small quantity of oil on the bar and move the assembly 3 or 4 times.
- Clean as required to remove excess of oil.

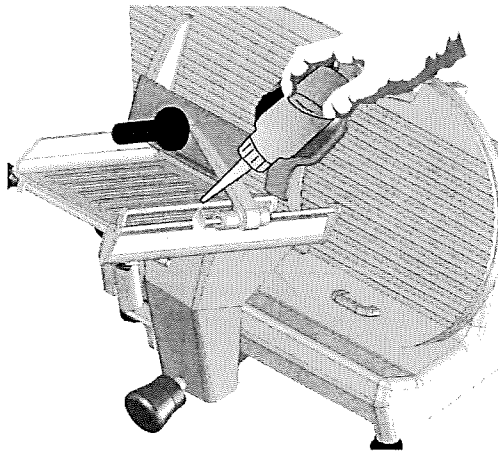
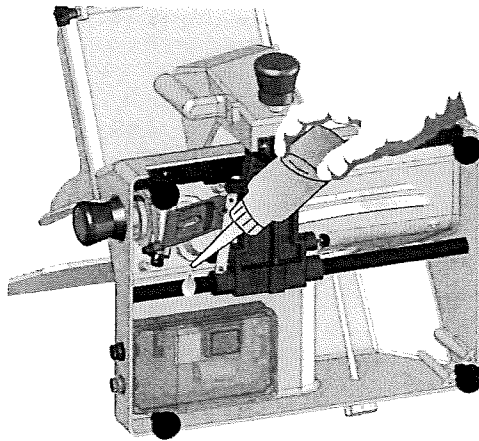

## TROUBLESHOOTING AND REMEDIES

The table below indicates the most common problems that may arise during slicing and the necessary remedies.

<b>PROBLEM</b>	<b>POSSIBLE CAUSE</b>	<b>REMEDY</b>
The machine does not start when the green button is pressed	No power supply The blade guard is not correctly positioned. Defective electrical control circuit.	Ascertain that the plug is correctly inserted. Check Call technical assistance
The machine does not start, and there is continuous noise like a buzz only in the case of machines equipped with three-phase motors.	The motor is running on single-phase mode	Press the red button immediately and have the power supply cord and the circuits upstream verified by qualified personnel.
When the green button is pressed, the machine starts, but the white functioning light is not on.	Defective indicator	Do not use the machine when the pilot lamp is not on. Call technical assistance
The machine starts, but there are vibrations. The motor is very hot and there is a bad smell.	Defective motor or transmission.	Do not use the machine. Call technical assistance.
Under strain, the machine slows down or comes to a stop.	Defective transmission	Call technical assistance
Excessive resistance to product slicing.	The blade is blunt	Sharpen the blade
The slices are ragged and/or shaped irregularly	The blade is blunt The blade is excessively worn out	Sharpen the blade Call technical assistance
Unsatisfactory blade sharpening	Worn wheels	Replace the grinding stones. Call technical assistance
The product tray does not slide	Guides are insufficiently lubricated	Lubricate
When the red button is pressed, the machine does not stop	Defective electrical control circuit	Stop the machine, unplug from mains and call technical assistance

## **DISMANTLING THE SLICER**

This machine is made of the following elements:

- Aluminium frame;
- Stainless steel fittings and others;
- Electrical parts and wires;
- Electrical motor;
- Plastic materials, etc.

Whether dismantling is entrusted to third parties or done in-house (in that last case you will have to separate the various materials) please note that disposal of the materials can only be carried out by duly authorised businesses.

In any case, please comply to the current norms of your country.

## **WARNING**

*In any case, to remove the blade and dispose of it, you must contact the manufacturer or personnel duly authorized by the manufacturer.*

***NEVER DISPOSE OF WASTE IN AREAS WHERE ACCESS IS NOT DELIMITED BY BARRIERS AND FORBIDDEN BY WARNING SIGNS AS THIS WASTE REPRESENTS A SERIOUS DANGER, ESPECIALLY FOR CHILDREN AND ANIMALS. ANY RESPONSIBILITY ARISING OUT OF INCORRECT DISPOSAL FALLS ON THE OWNER.***



**BIRO**  
Recommended Spare Parts  
May 2011



Z9MAF  
Sharpening stone

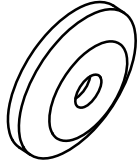

GRSTA  
Electrical Box Assembly Mono-Phase 115V-60Hz

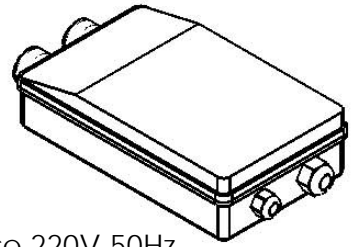

Z9MSB  
Cleaning stone

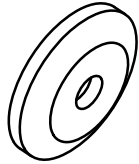

GRSTS  
Electrical Box Assembly Mono-Phase 220V-50Hz

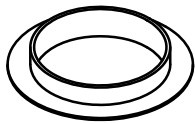

Z9TCA  
Mono phase card 115V-60Hz

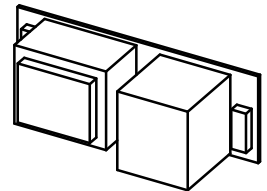

Z9SCH  
Single phase card 220V-50Hz

X0090 : B300M  
G111-A : B350M-B350A-B350MV  
Water-ring protection

B300M :  
M9346 UP S/N 90764  
G7CIN FROM S/N 90765

B350 M :  
G5CIN UP S/N 80415  
G8CIN FROM S/N 80416

B350 A :  
G5CIN UP S/N 10801  
G8CIN FROM S/N 10802

B350 MV :  
G5CIN UP S/N 90732  
G8CIN FROM S/N 90733

Trasmission Belt

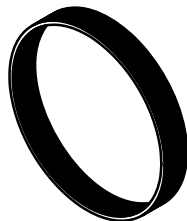

Z9PIE  
Foot

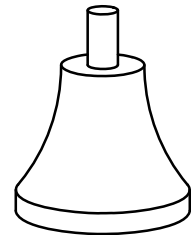

B300 M :  
AF02US

B350 M - B350 A :  
AF01US

B350 MV :  
AF03US

Sharpener

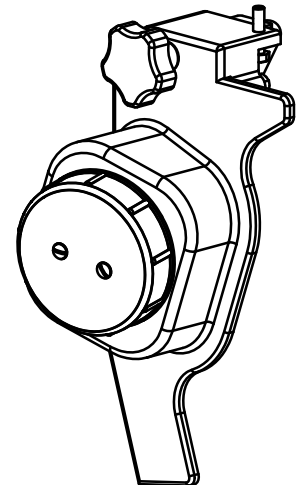

MODEL 300 :  
G9320

MODEL 350 STND :  
Z5L4G

MODEL 350 3rd GEN. :  
Z5L3G

Blade

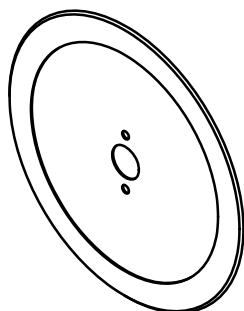

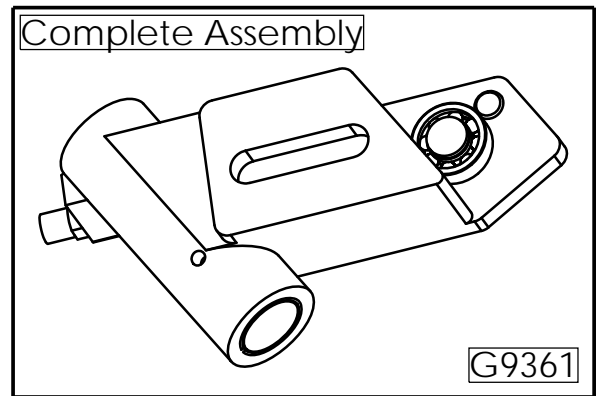
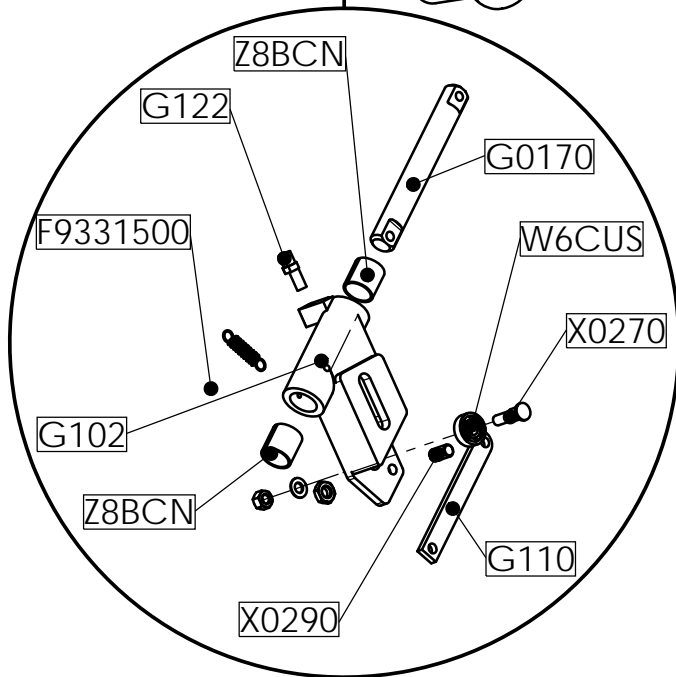
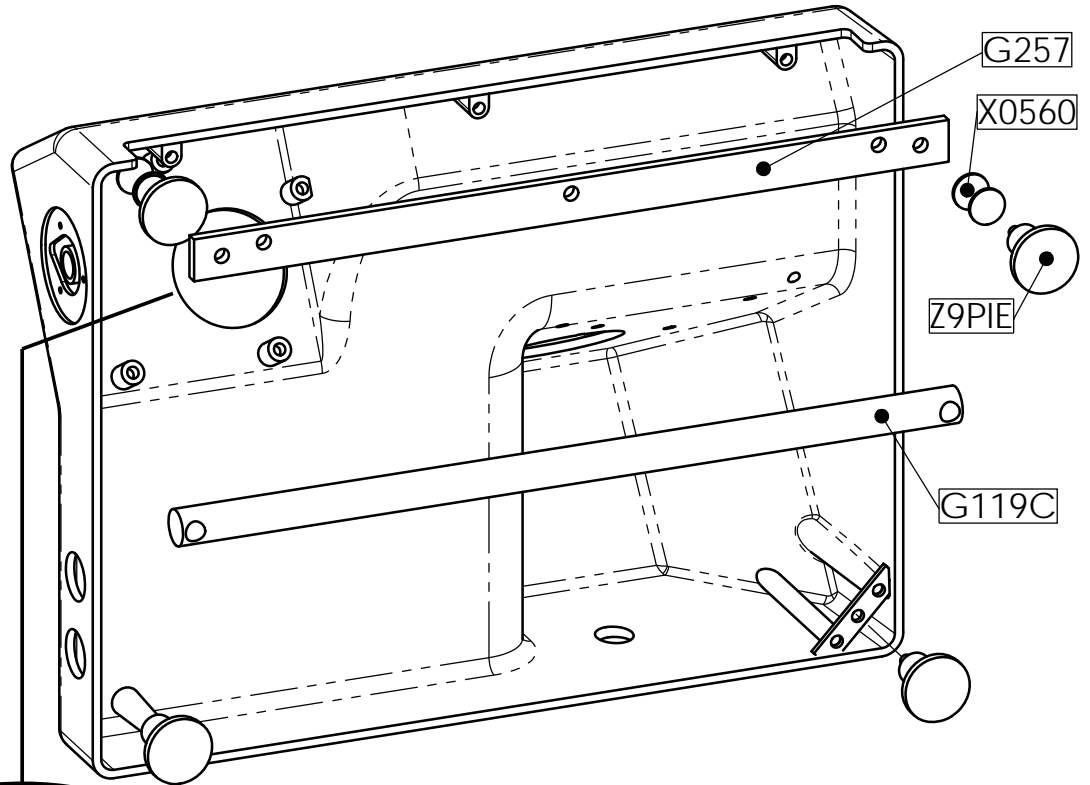

CODE	DESCRIPTION	Q,TY
F9331500	SPRING d 10 L 55	1
G0170	ROD - INDEX SLIDE	1
G102	SLIDE - INDEX MECHANISM	1
G110	ROD - INDEX ANTI ROTATION	1
G119C	SLIDE ROD - 25 x 578	1
G122	PIN - INDEX CAM	1
G257	SS BAR - TRANSPORT ROLLER	1
<b>G9361</b>	<b>SLIDE INDEX COMPLETE ASSEMBLY</b>	
W6CUS	SS BEARING 6000 ZZ 10 x 20 X 6	1
X0270	BEARING PING 10 x 30 M6	1
X0290	GUIDE - INDEX MECHANISM	1
X0560	SS FOOT SPACER 25 x 44 M8	2
Z8BCN	BUSHING 20 23 20E	2
Z9PIE	FOOT	4

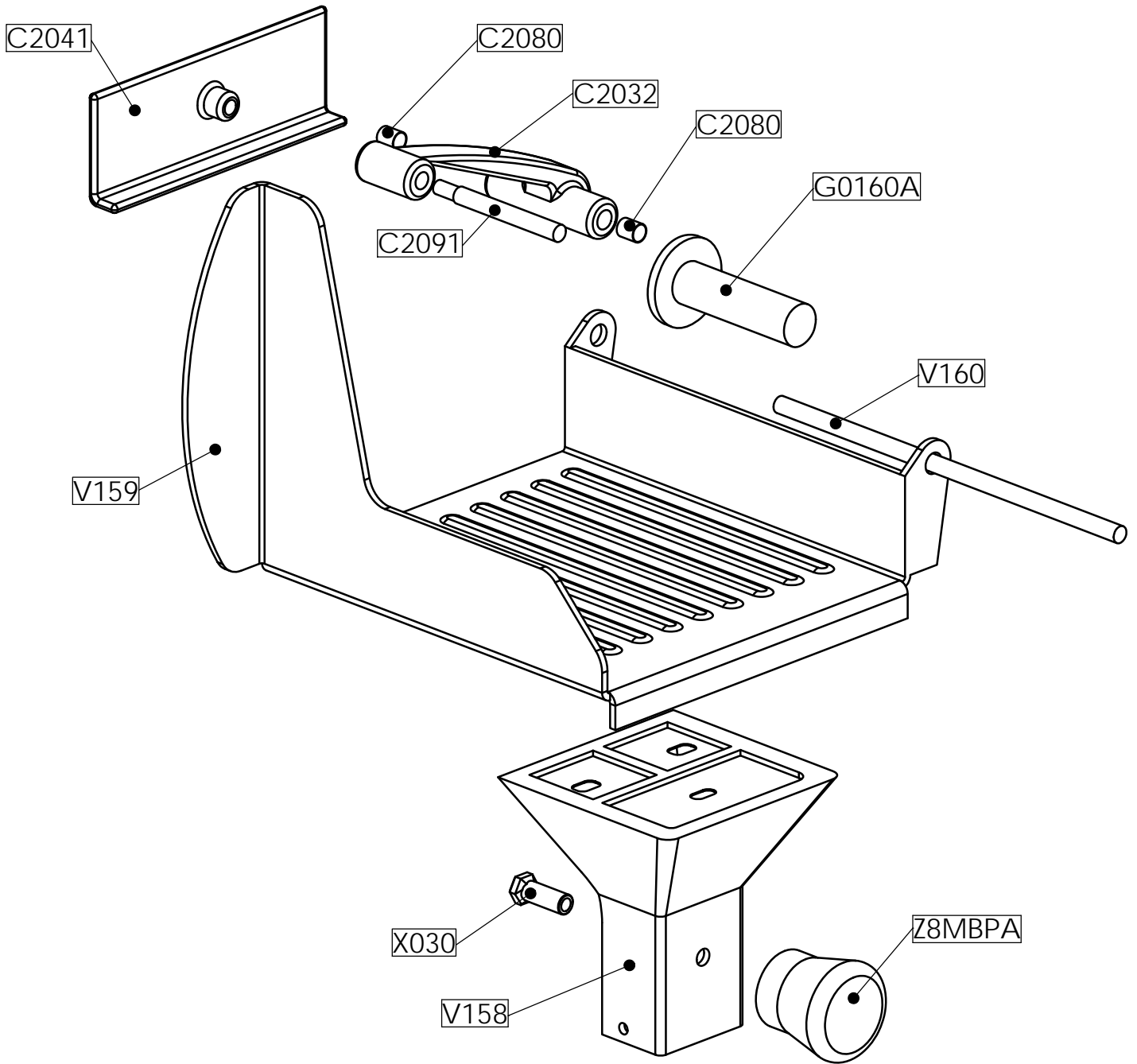

CODE	DESCRIPTION	Q, TY
C2032	MEAT GRIP HOLDER	1
C2041	MEAT GRIP	1
C2080	BUSHING	2
C2091	HANDLE ASSY	1
V159	CARRIAGE TRAY	1
V160	SLIDE ROD ASSY	1
G0160A	HANDLE	1
V158	SUPPORT - TRAY ASSY	1
X030	KNOB SHAFT	1
Z8MBPA	KNOB - SUPPORT TRAY	1



G200 COMPLETE ASSEMBLY

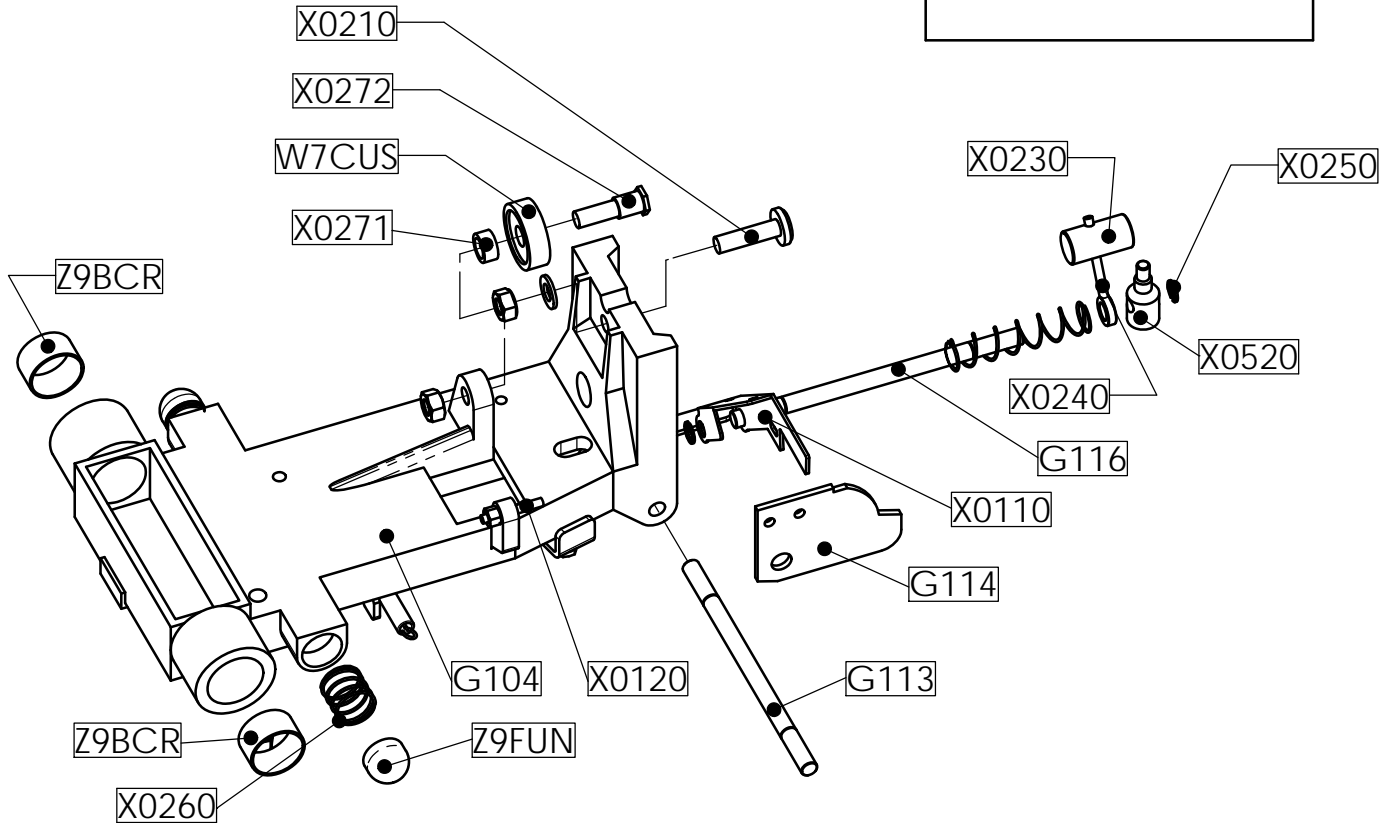
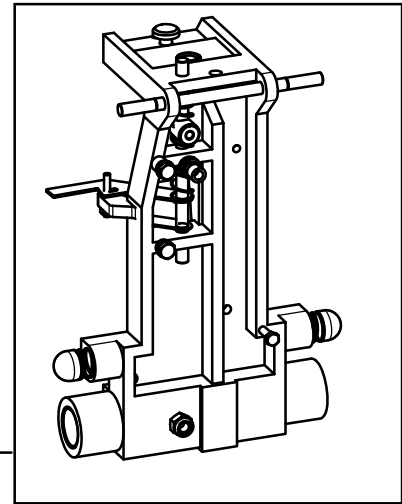
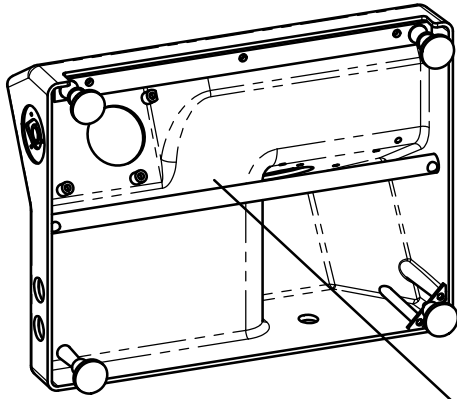

CODE	DESCRIPTION	Q.TY
G104	CARRIAGE	1
G113	SHAFT - PIVOT RETURN	1
G114	COVER - CARRIAGE	1
G116	LOCKING CARRIAGE SHAFT	1
<b>G200</b>	<b>COMPLETE CARRIAGE ASSEMBLY</b>	
W7CUS	BEARING	1
X0110	BRACKET	1
X0120	GUIDE PIN	1
X0210	CAP SCREW	1
X0230	LOCKING SUPPORT TRAY ASSY	1
X0240	LOCKING SHAFT MECHANISM	1
X0250	SPRING - LOCKING CARRIAGE	1
X0260	SPRING - CARRIAGE	2
X0271	SPACER - BEARING	1
X0272	BEARING PIN	1
X0520	LOCKING SHAFT MEC. PART 2	1
Z9BCR	BUSHING 25 28 25 E	2
Z9FUN	BUMPER - SLIDE ROD	2

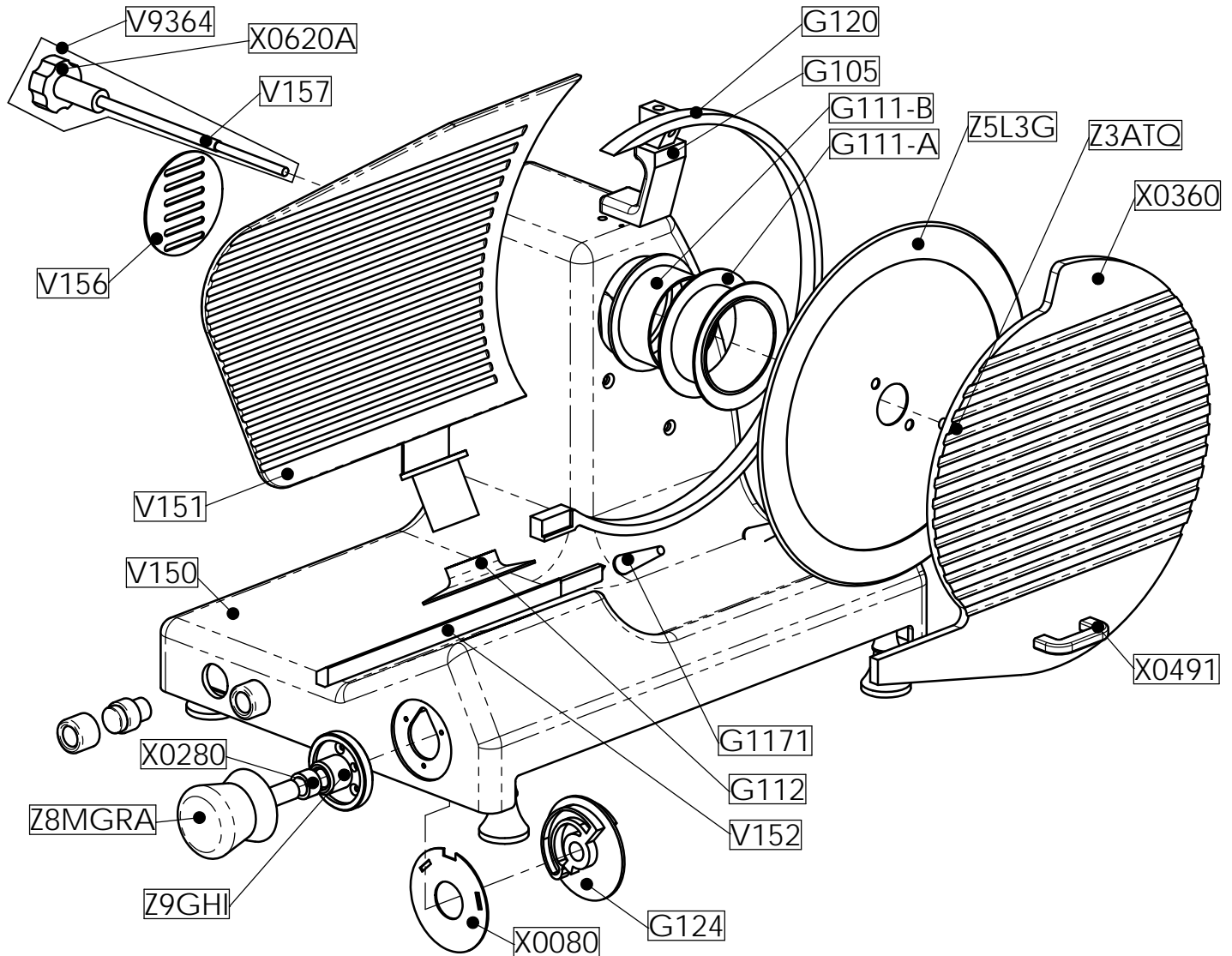

COD	DESCRIPTION	Q.TY
G105	RING STUDBOLT	1
G111-A	BLADE SEAL	1
G111-B	BLADE SEAL	1
G112	GUAGE PLATE SEAL	1
G1171	RING SPACER	1
G120	BLADE GUARD RING	1
G124	CAM	1
<b>V9364</b>	<b>BLADE GUARD ROD - ASSEMBLY</b>	
V150	FRAME	1
V151	GAUGE PLATE	1
V152	MEAT HOLDER	1
V156	SS COVER	1
V157	BLADE GUARD ROD	1
X0080	CAM SPACER	1
X0280	CAM SPACER	1
X0491	HANDLE COVER BLADE	1
X0620A	BLADE GUARD ROD KNOB	1
Z3ATQ	BLADE GUARD LOCKING SCREW 12x12	1
Z5L3G	BLADE 350/57 mm 100Cr6 (3RD GEN.)	1
Z6COP	BLADE GUARD	1
Z8MGRA	ADJUSTABLE KNOB 0:21	1
Z9GHI	KNOB SPACER 76,6	1

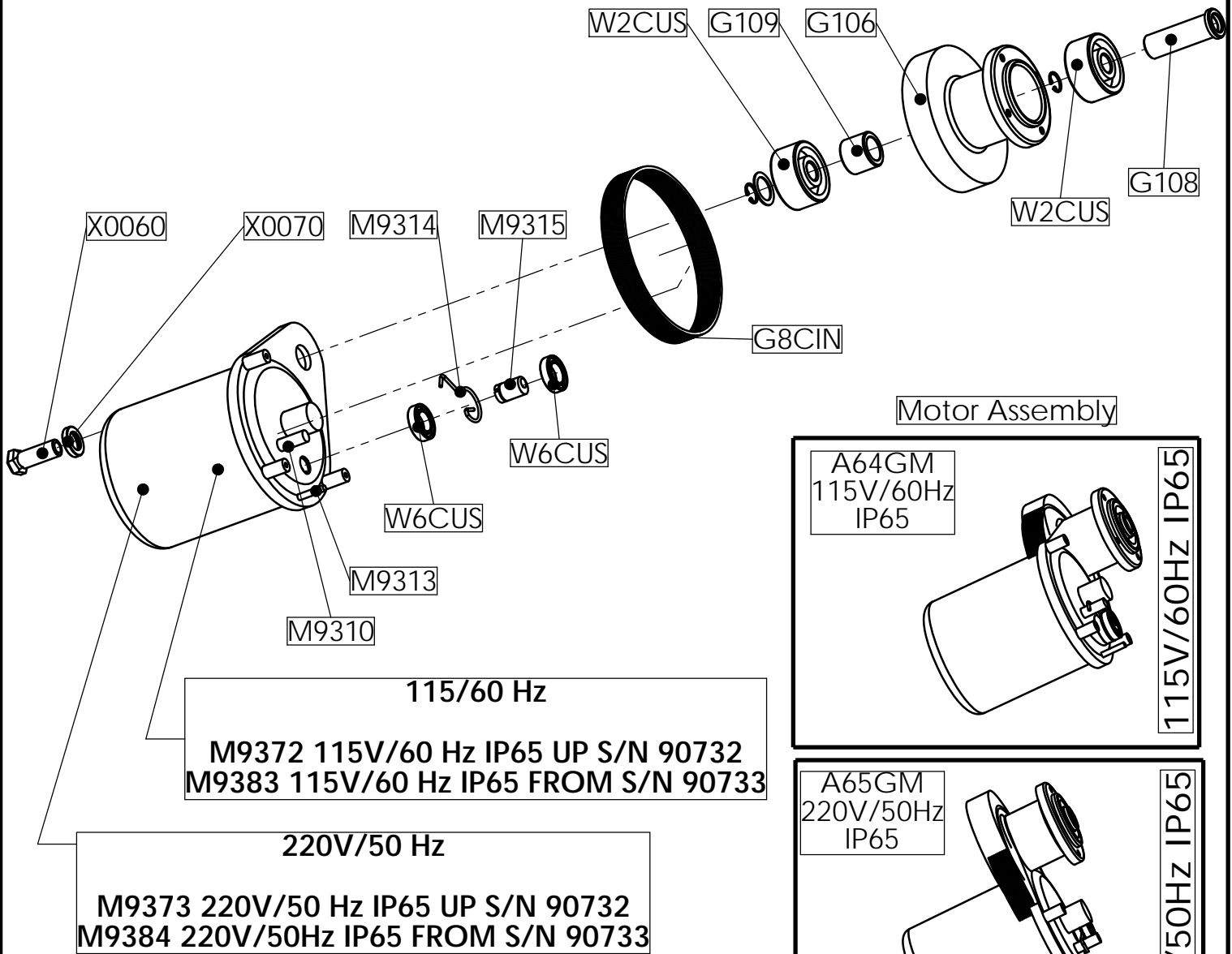

CODE	DESCRIPTION	Q.TY
G106	PULLEY B 350 M	1
G108	SHAFT - KNIFE 25 x 97	1
G109	SPACER	1
G8CIN	BELT TB2 11 x 400	1
M9310	PIN 25 x 5	1
M9313	RING SUPPORTING SPRING 20 x 6	1
M9314	BEARING TENS. SPRING	1
M9315	BEARING PIN	1
M9383	MOTOR - IP 65 115 VOLT 60 Hz	1
M9384	MOTOR - IP 65 220 VOLT 50 Hz	1
W2CUS	SS TRANSMISSION BEARING	2
W6CUS	SS BEARING 6000 ZZ 10 x 20 X 6	2
X0060	CAP SCREW	1
X0070	LOCK WASHER	1
CODE	DESCRIPTION	Q.TY
A64GM	MOTOR ASSEMBLY IP 65 115V / 60Hz	1
A65GM	MOTOR ASSEMBLY IP 65 220V / 50Hz	1

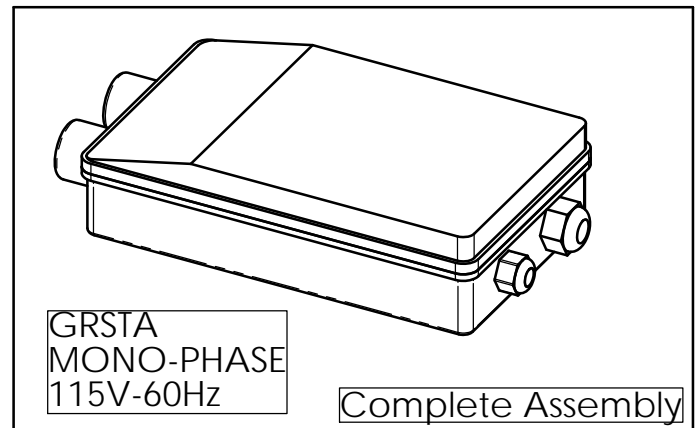
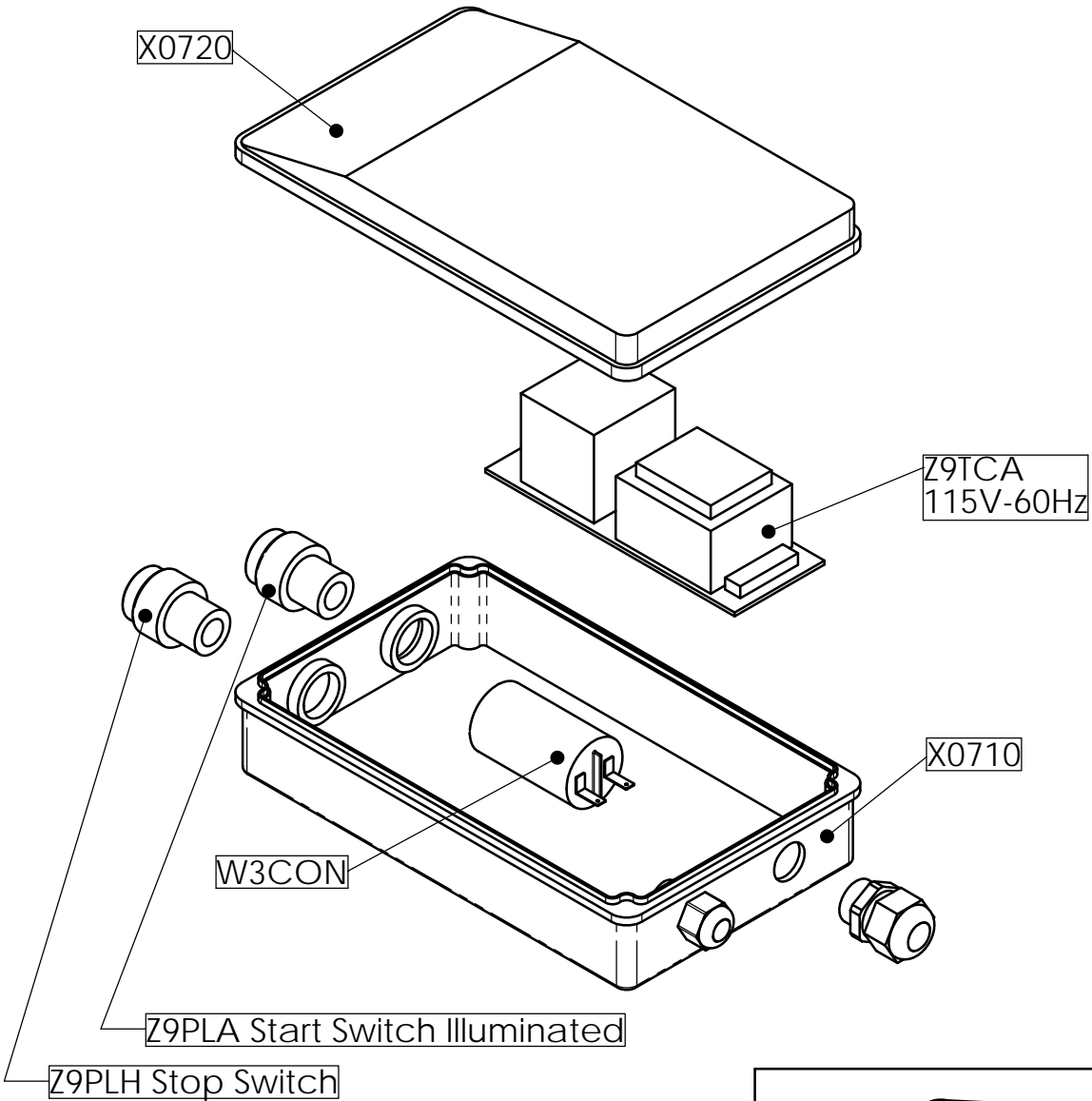

CODE	DESCRIPTION	Q.TY
GRSTA	COMPLETE CONTROL BOX	
W3CON	CAPACITOR 20 Mf	1
X0710	ELECTRIC BOX - BASE	1
X0720	PLASTIC COVER	1
Z9PLA	START SWITCH - IP 69	1
Z9PLH	STOP SWITCH - IP 69 RED	1
Z9KAP	SWITCH PROTECTION	2
Z9TCA	CARD 115/60Hz -	1

AF03US

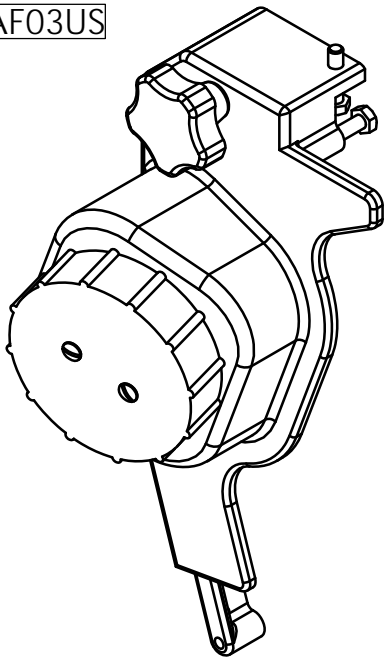

Complete Assembly

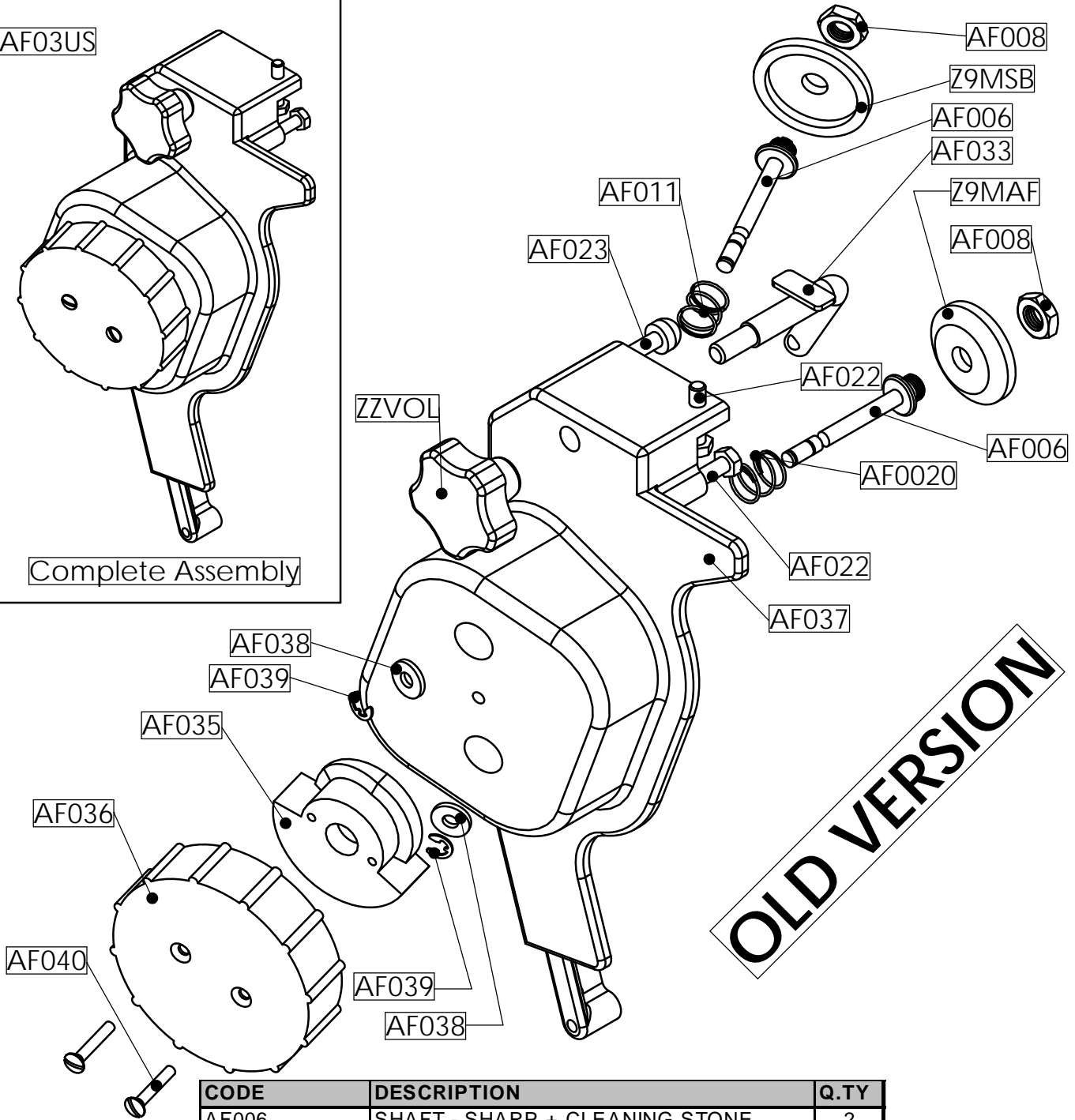

**OLD VERSION**

CODE	DESCRIPTION	Q.TY
AF006	SHAFT - SHARP + CLEANING STONE	2
AF008	NUT - SPECIAL	2
AF011	SPRING - CLEANING STONE	1
<b>AF03US</b>	<b>SHARPENER - COMPLETE ASSEMBLY</b>	
AF020	SPRING - SHARPENING STONE	1
AF022	SCREW - PLASTIC	3
AF023	SCREW - MAIN GUIDE - PLASTIC	1
AF033	ARM	1
AF037	HOUSING	1
AF035	SHARPENER CAM	1
AF036	KNOB - SHARPENER	1
AF038	WASHER - PLASTIC	2
AF039	RING - RETAINER - UNI 7434	2
AF040	SCREW - TC 5 x 10	2
Z9MAF	STONE - SHARPENING	1
Z9MSB	CLEANING STONE	1
ZZVOL	KNOB - BLADE G. + SHARPENER	1

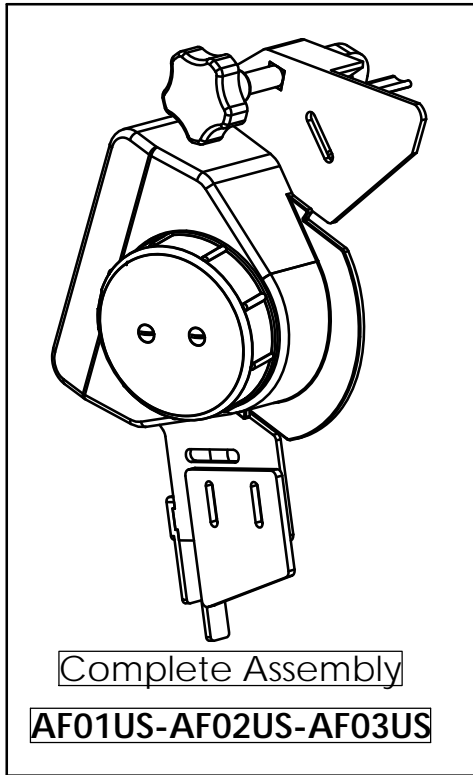
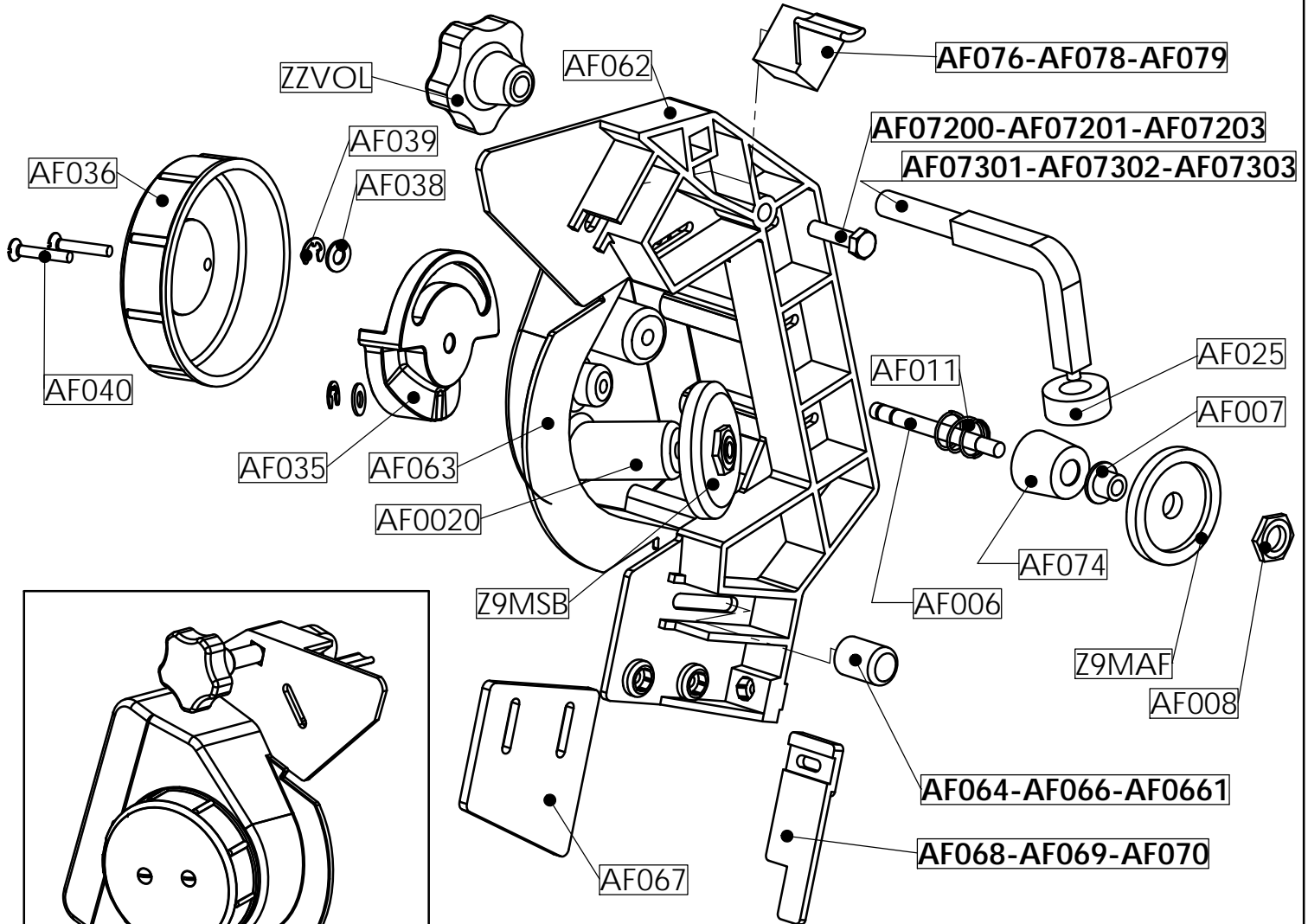

CODE	DESCRIPTION	Q.TY
AF006	SHARPENER SHAFT 6x68	2
AF007	BUSHING	2
AF008	NUT - SPECIAL	2
AF011	SPRING - CLEANING STONE	1
AF020	SPRING - SHARPENING STONE	1
AF025	PLASTIC WHEEL	1
AF035	SHARPENER CAM - NOT INTEGRATED	1
AF036	KNOB - SHARPENER	1
AF042	BUSH 12x27 hole 5.9	2
AF062	PLASTIC SHARPENER DEVICE	1
AF063	SEPARATED SHARPENER BOX	1
AF064	SEP. SHARP. FOOT B 300 M	1
AF066	SEP. SHARP. FOOT B 350 MV	1
AF0661	SEP.SHARP. FOOT B350 M / B350 A	1
AF067	SEP.SHARP. COVER PLATE - ALL	1
AF068	PROTECTION B300 M	1
AF069	PROTECTION B350 M / B350 A	1
AF070	PROTECTION B350 MV	1
AF07200	PIN B300 M	1
AF07201	PIN B350 MV	1
AF07203	PIN B350M / B350 A	1
AF07301	LOCKING SHAFT B350 MV	1
AF07302	LOCKING SHAFT B300 M	1
AF07303	LOCKING SHAFT B350 M / B350 A	1
AF074	DUST COVER ALL	2
AF076	REFERING FOOT B300 M	1
AF078	REFERING FOOT B350 MV	1
AF079	REFERING FOOT B350 M / B350 A	1
Z9MAF	STONE - SHARPENING	1
Z9MSB	STONE - CLEANING	1
ZZVOL	KNOB	1
<b>ASSEMBLY</b>		
AF01US	COMPLETE ASS.BLY B350 M / B350 A (30mm OPENING)	
AF02US	COMPLETE ASS.BLY B300 M	
AF03US	COMPLETE ASS.BLY B350 MV	

**MODEL: B300M - B350M - B350MV**

3-PHASE VOLTAGE L1-L2-L3  
 1-PHASE VOLTAGE L1-L2

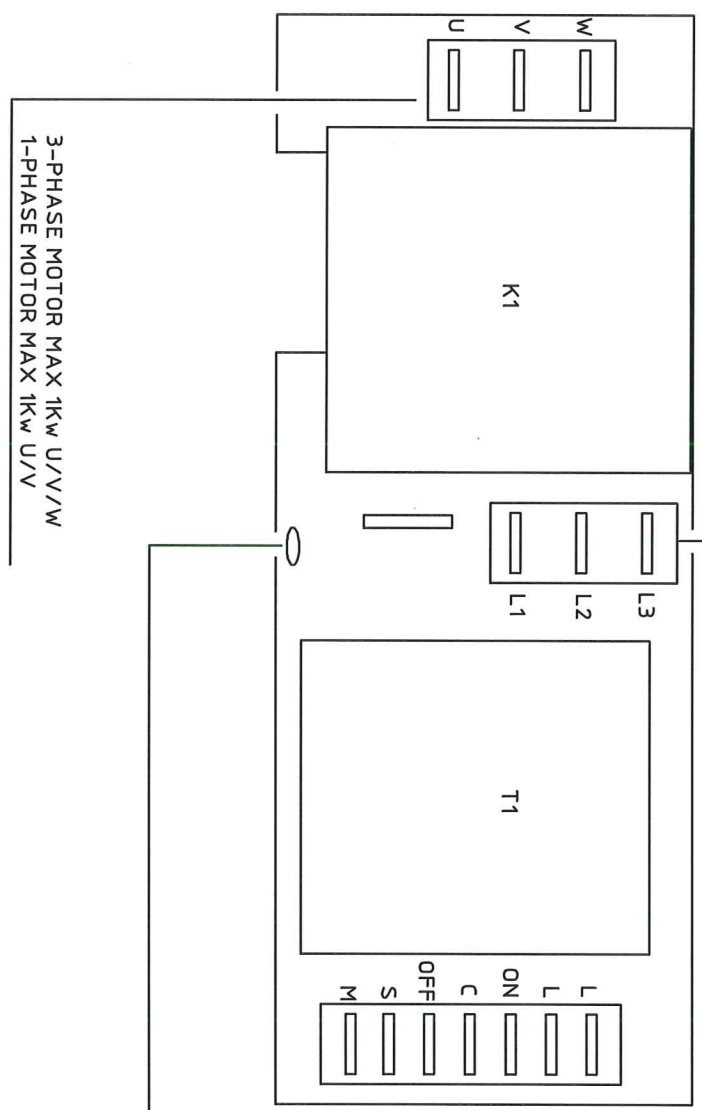

3-PHASE MOTOR MAX 1KW U/V/W  
 1-PHASE MOTOR MAX 1KW U/V

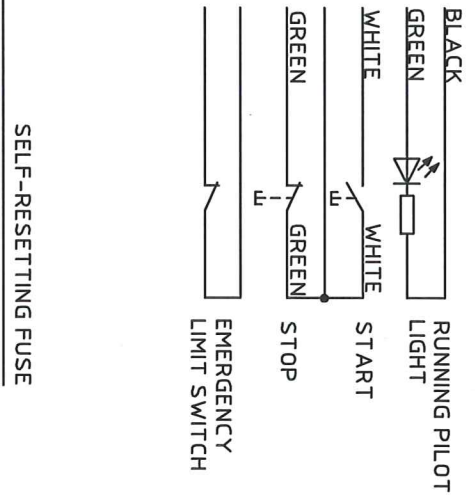

SELF-RESETTING FUSE

<p style="font-size: 2em; text-align: center;">BIRRO</p>		Dis. N. B350M		Impianto		Ordine		FOGLIO	
		CAD <b>SPAC</b>		ON-OFF CIRCUIT BOARD		Commissa B350M		3	
Nome File AMB0201		Denominazione		CONNECTION DIAGRAM		Esecutore AR		SEQUE	
Data 02-04-2008								/	