



MODEL
3334FH & 3334-4003FH
FIXED HEAD POWER MEAT CUTTER
OPERATING AND SERVICE MANUAL



★ **IMPORTANT NOTICE** ★

This Manual contains important safety instructions which must be strictly followed when using this equipment.

TABLE OF CONTENTS

	PAGE
NOTICE TO OWNERS AND OPERATORS	1
SAFETY TIPS	2
INSTALLATION	3
WARNING LABELS FOR POWER CUTTERS	6
WARNING LABEL LOCATIONS ON MACHINE	7
BAND SAW SAFETY GUIDELINES	8
OPERATION	9
FOOD HANDLING TO PREVENT CONTAMINATION	9
TO PROCESS PRODUCT	10
MAINTENANCE	10 & 11
GENERAL	11
LUBRICATION	11
PARTS DIAGRAMS	12-15
BLADE TENSION SCREW INSTALLATION INSTRUCTIONS	16
OPERATOR'S NOTES	17
PARTS DIAGRAMS	18-29
LEFT BASE DOORS - MOTOR ADJUSTMENT	24
LONGER SAW GUARD KIT	25
LOWER REMOVABLE WHEEL PARTS DIAGRAM & INSTALLATION	26-29
OPERATOR'S NOTES	30
SWITCH ASSEMBLIES AND SERVICE PARTS	31-32
WIRING DIAGRAMS	33-39
OPERATOR'S NOTES	40
CLEANING PROCEDURE	41
PARTS LIST/ORDERING	42
PARTS ASSEMBLIES LIST/ORDERING	43
WEARABLE SAW PARTS LIST	44
OPERATOR'S SIGNATURE PAGE	45
LIMITED WARRANTY	46

NOTICE TO OWNERS AND OPERATORS

BIRO's products are designed to process food products safely and efficiently. Unless the operator is properly trained and supervised, however, there is the possibility of a serious injury. It is the responsibility of the owner to assure that this machine is used properly and safely, strictly following the instructions contained in this Manual and any requirements of local law.

No one should use or service this machine without proper training and supervision. All operators should be thoroughly familiar with the procedures contained in this Manual. Even so BIRO cannot anticipate every circumstance or environment in which its products will be used. You, the owner and operator, must remain alert to the hazards posed by the function of this equipment – particularly the SHARP MOVING BAND TYPE SAW BLADE. No one under eighteen (18) years of age should operate this equipment. If you are uncertain about a particular task, ask your supervisor.

This Manual contains a number of safe practices in the SAFETY TIP section. Additional warnings are placed throughout the Manual. Warnings related to your personal safety are indicated by:



OR



Warnings related to possible damage are indicated by:



BIRO also has provided a wall chart to be posted near the equipment. If any warning label, wall chart, or Manual becomes misplaced, damaged, or illegible, please contact your nearest Distributor or BIRO directly for a replacement.

Remember, however, this Manual or the warning labels do not replace the need to be alert and to use your common sense when using this equipment.

This Manual applies to 3334FH & 3334-4003FH Power Meat Cutters with Fixed Heads.

– NOTE –

A copy of this manual is included with each MODEL 3334FH & 3334-4003FH FIXED HEAD POWER MEAT SAW.

The descriptions and illustrations contained in this manual are not binding. The manufacturer reserves the right to introduce any modification without updating the manual.

SAFETY TIPS

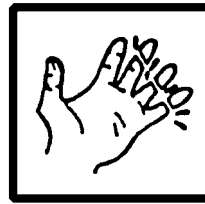
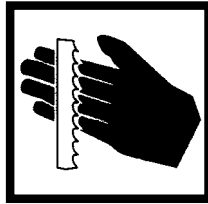

SHARP MOVING BAND TYPE SAW BLADE TO AVOID SERIOUS PERSONAL INJURY

- NEVER** Touch This Machine Without Training and Authorization By Your Supervisor.*
- ALWAYS** Read Operation and Parts Manual **BEFORE** Operating, Cleaning or Servicing.*
- ALWAYS** Keep Hands Clear of Sharp Band Type Saw Blade and Other Moving Parts.*
- ONLY** Use a Qualified Electrician to Install According to Local Building Codes: Machines **MUST** Be Properly Grounded.*
- ONLY** Install on Level, Non-Skid Surface in a Clean, Well-Lighted Area Away From Children and Visitors.*
- DO NOT** Attempt to Operate This Machine Until it has Been Inspected and Demonstrated by the Seller – Recognized **BIRO** Representative.*
- DO NOT** Alter or Modify This Machine in any Way From its Original Form. This Machine in its Original Form Meets the Intent of O.S.H.A. Applicable Standards.*
- NEVER** Operate with Saw Guard on Saw Guide Bar in the Raised Position or the Saw Guard Removed from the Saw Guide Bar.*
- ALWAYS** Adjust the Saw Guide Bar with Saw Guard to Within $\frac{1}{2}$ " of Product to be Cut.*
- ALWAYS** Use Supplied Safety End Cut Pusher Plate for Smaller Products or The Last Cuts of Product.*
- DO NOT** Use This Machine for Non-Food Products.*
- DO NOT** Use This Machine to Cut Pigs Feet.*
- DO NOT** Wear Gloves While Operating.*
- ALWAYS** Turn Off, Unplug From Power Source and Perform Lockout/Tagout Procedure to This Machine **BEFORE** Removing Shrouds, Removable Guards, Covers, Doors, Fences or Panels for Cleaning, Servicing or Any Other Reason.*
- NEVER** Leave Machine Unattended While Operating.*
- PROMPTLY REPLACE** Any Worn or Illegible Warning Labels.*
- USE ONLY BIRO** Parts and Accessories Properly Installed.*

INSTALLATION



TO AVOID SERIOUS PERSONAL INJURY PROPERLY INSTALL EQUIPMENT IN ADEQUATE WORK AREA

ALWAYS Read Operating and Parts Manual **BEFORE** Installation.

ALWAYS Use Qualified Technician and Electrician for Installation.

ALWAYS Install Equipment in Work area with Adequate Light and Space.

ONLY Operate on a Solid, Level, Non-Skid Surface.

DO NOT Attempt to Operate This Machine Until It has been Inspected and demonstrated by the Seller – Recognized BIRO Representative.

DO NOT Alter or Modify This Machine in Any Way from its Original Form. This Machine in its Original Form Meets the Intent of O.S.H.A. Applicable Standards.

NEVER Operate with Saw Guard on Saw Guide Bar in the Raised Position or the Saw Guard Removed from the Saw Guide Bar.

ALWAYS Adjust Saw Guide Bar with Saw Guard to Within $\frac{1}{2}$ " of Product to be Cut.

NEVER Operate Without all Warning Labels Attached and Wall Chart Posted.

USE ONLY BIRO Parts and Accessories Properly Installed.

1. Read this Manual thoroughly before installation and operation. **Do not** proceed with installation and operation if you have any questions or do not understand anything in this Manual. Contact your local Distributor, or BIRO first.
2. Install machine on a level, solid, non-skid surface in a well-lighted work area away from children and visitors.



ALWAYS LEVEL MACHINE BEFORE USING

3. After installing machine in operational area, it is imperative that the four adjusting leg hex bolts be adjusted to level the machine.
4. To install the meat gauge plate assembly to the machine. Loosen the lock knob. Raise the gear rack. Slide the meat gauge arm over the gear rack. Be sure to hold meat gauge arm so that the release handle is depressed. Lower the gear rack to original position. Tighten the lock knob. Keep gear rack well oiled with a food grade oil to ensure free movement.

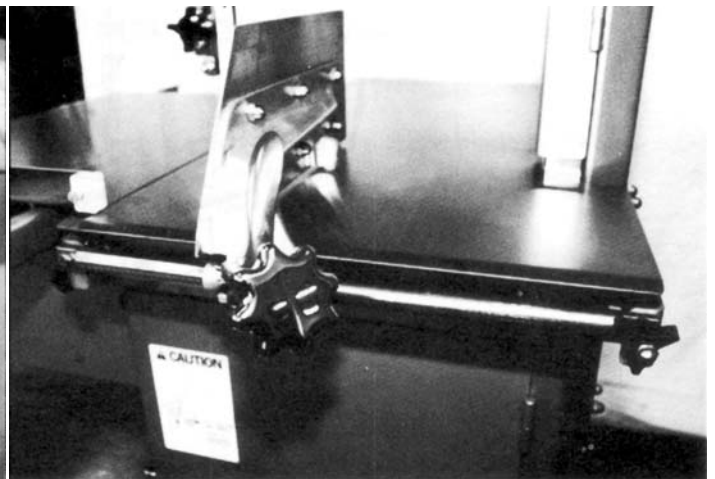
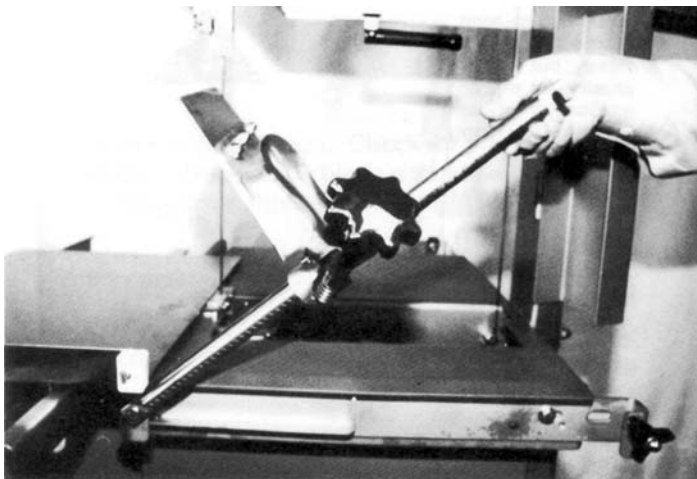

5. Place removable finger lift with saw guard assembly on the saw guide bar and fasten in place with four point finger lift fastener knob.
6. The side platter bracket is packed loose in the machine and must be installed on the left side of the base structure with the supplied hardware and checked for proper adjustment.
7. Machine **MUST** be properly grounded. Use qualified electrician to install according to building codes.

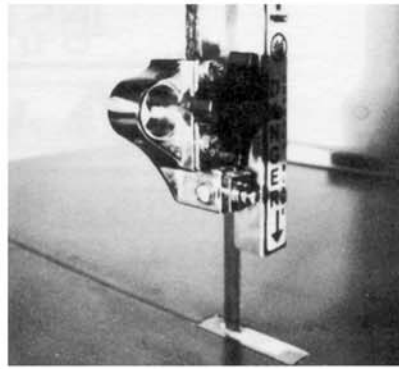

**FINGERLIFT
ASSEMBLY**

WIRING MOTOR

- (1) Interchange of motor current is made in motor outlet box. Leads are properly marked. Changing instructions are on motor plate or inside junction box cover.
- (2) All saws are wired 220 volts unless otherwise specified. Be sure motor specifications (voltage, cycle, phase) match power supply line. Be sure line voltage is up to specification.
- (3) Connect leads to machine in a manner that will be approved by local electrical inspectors.
- (4) We recommend no less than No. 12 wire. If the leads are too light, machine may not have sufficient cutting power and/or speed.
- (5) The drive belt is packed loose in machine to prevent deformation, and must be installed on pulleys at time of wiring motor.
- (6) The BIRO Manufacturing Company is not responsible for permanent wiring, connection or installations.



NOTE TO OWNER AND ELECTRICIAN: IF THIS MACHINE IS NOT CORD AND PLUG CONNECTED TO THE ELECTRICAL SUPPLY SOURCE, THEN IT SHOULD BE EQUIPPED WITH, OR CONNECTED TO, A LOCKABLE, MANUALLY OPERATED DISCONNECT SWITCH (OSHA 1010.147).

8. All machines are tested at the factory, but electrical phasing for proper rotation may not match your electrical supply. Some Model 3334's have removable lower wheel when the option is ordered from the factory. All machines with removable lower wheel must be first test run for proper phasing with the lower wheel removed. Failure to remove the lower wheel could cause the wheel to become dislodged during testing.

All machines with removable lower wheel will display the following decal on the right hinged base door.



**** This saw has been equipped with a "REMOVABLE" lower wheel****

**ATTENTION: ELECTRICIAN/SERVICE TECHNICIAN
** READ FIRST BEFORE STARTING POWER CUTTER ****

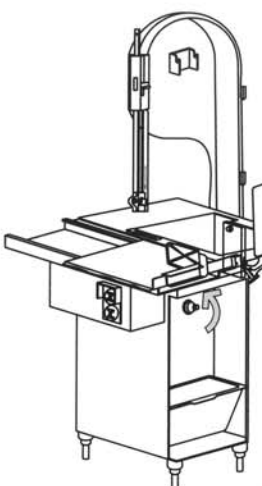

IMPORTANT

This saw has been electrically tested at the factory, but electrical phasing for proper rotation may not match your electrical supply.

WITH LOWER SAW WHEEL REMOVED, check rotation of shaft. Rotation must be counterclockwise when facing shaft.

Failure to confirm correct rotation could result in the wheel dislodging.

16716



SHARP SAW BLADE. HANDLE WITH EXTREME CAUTION.

9. Placing blade on cutter: Unpack upper wheel assembly and hang on the hinge bracket in the head structure. Lift the nylon filler in the stationary bar. Hang the blade on the upper wheel and hold with right hand. With the left hand force the back of the blade between the front blade scrapers, located below the stationary bar. Lower the nylon filler. Be sure the blade is in the upper saw guide. The blade has dropped over the lower wheel. Switch hands holding the blade on the upper wheel. With the right hand, force the blade between the rear blade scrapers. The blade is now ready to be tightened.
10. Turn the blade tensioning handle clockwise until the tension mark is even with the bottom of the upper wheel hinge plate as shown. Carefully turn saw wheels by hand and watch for proper tracking of blade on the wheels.

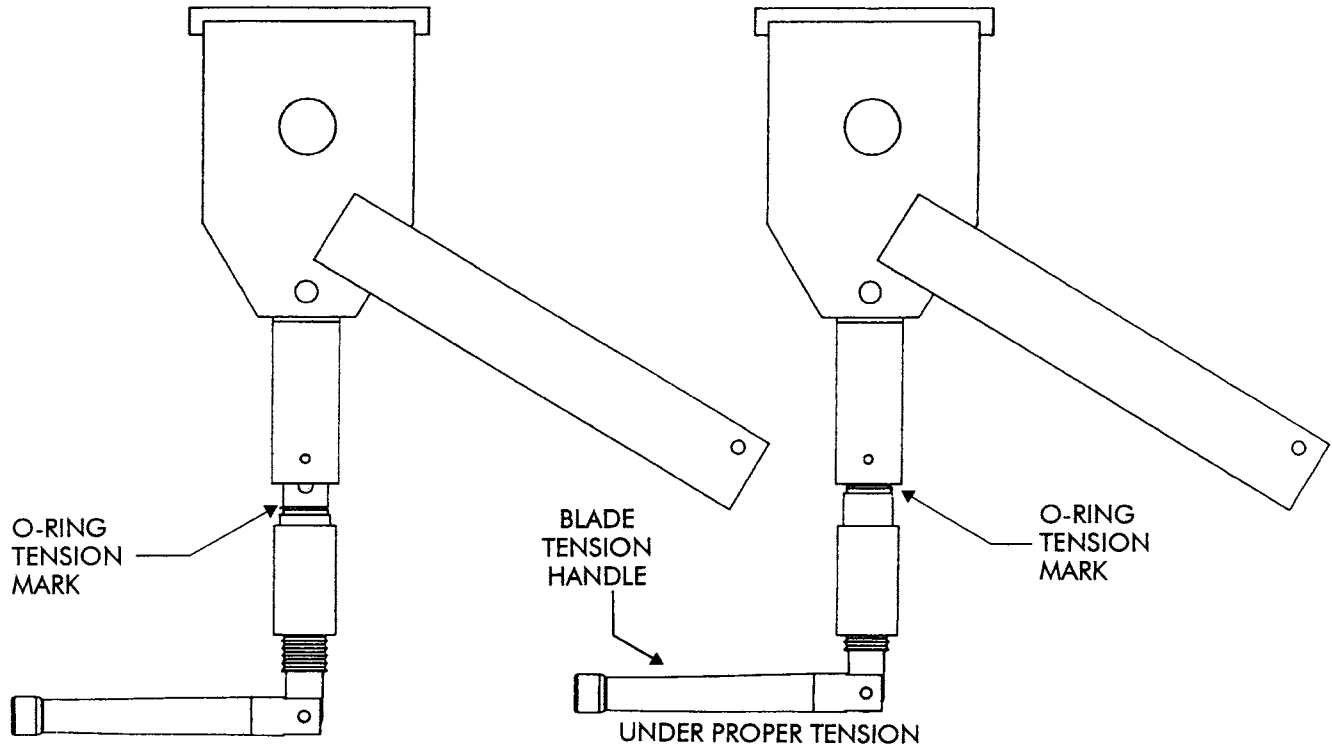

11. The stationary platter is placed on top of the base structure and held in place by two platter hold down catches located in the base structure.
12. The sliding meat carriage assembly is installed on the channel. Start by turning the movable stop assembly clockwise. After the carriage assembly has been installed on the channel for operation, turn the movable stop assembly counterclockwise to lock.
13. Make sure saw guide bar with saw guard is in its lowest position. Close head and base doors.



KEEP HANDS CLEAR OF SHARP MOVING BAND TYPE SAW BLADE

14. Push the start button. Check for proper phasing of the motor and proper tracking of the saw blade in the saw guides. Back of the blade should be centered in the lower saw guide in the stationary bar. Blade should be moving down through the guide. Push the stop button to stop the machine.
15. Check placement of all warning labels, wall chart and Manual. Machine is ready for trained operators to process product.
16. Contact your local Distributor or BIRO directly if you have any questions or problems with the installation or operation of this machine.

WARNING LABELS FOR BIRO POWER CUTTERS



WARNING



DO NOT Use Unless Trained and Authorized By Supervisor And Over 18 Years Old.
Read Operation Manual Thoroughly Before Operating.
ALWAYS Keep Hands Clear of Saw Blade and Other Moving Parts. Turn Off Saw when Finished Cutting.
ALWAYS Keep Blade Guard Adjusted to 1/2" Above the Product being Cut.
ALWAYS Use End Cut Pusher Plate When Cutting Smaller Piece of Product.
DO NOT Use Saw if it is Altered, Damaged, Improperly Maintained, or If Warnings Are Illegible or Missing.
ALWAYS Disconnect and Unplug from Main Power Source and Perform LOCKOUT/TAGOUT Before Cleaning or Servicing.

#653PC-E

ITEM No. 653PC-E: ALL SAWS
 1 ea. Attached to Head Below S/N Plate
 1 ea. Attached to Channel Bracket



MUCHO CUIDADO



NO Opere Esta Sierra Sin Haber Sido Entrenado Para Ello Ni Tampoco Sin Autorizacion de un Supervisor. Uno Tiene que Haber Cumplido 18 Anos Para Operarla.
LEA Cuidadosamente el Manual de Operacion Antes de Usar Este Equipo.
SIEMPRE Guarde las Manos a Salvo de la Hoja de Serrar y de Otras Partes Moviles. Cirre el Interruptor Despues de Terminar de Cortar.
SIEMPRE Tenga Adjustado el Guardasierra Para que Quede a 1/2" Por Encima del Producto que se Corta.
SIEMPRE Haga Uso de la Place de Empuje Para Cortes de Extremos al Cortar Trocitos Pequenos.
NO Utilice la Sierra si se Halla Alterada, Danadao si No ha Sido Debidamente Mantenido o si la Advertencia es Alegible o si Falta Esta.
SIEMPRE Desconnecte el Equipo Decenchifandolo de la Fuente de Fuerza. Dejelo Bajo Llave o con Etiqueta que Prohiba su Uso Antes de Limpialo o Hacer Trabajos de Mantenimento.

#653PC-SP

ITEM No. 653PC-SP: ALL SAWS
 1 ea. Attached to Channel Bracket

★ ★ ★ NOT TO SCALE ★ ★ ★



CAUTION

** This saw has been equipped with a "REMOVABLE" lower wheel**

ATTENTION: ELECTRICIAN/SERVICE TECHNICIAN
 ** READ FIRST BEFORE STARTING POWER CUTTER **

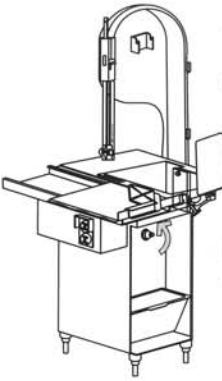

IMPORTANT

This saw has been electrically tested at the factory, but electrical phasing for proper rotation may not match your electrical supply.

WITH LOWER SAW WHEEL REMOVED, check rotation of shaft. Rotation must be **counterclockwise** when facing shaft. Failure to confirm correct rotation could result in the wheel dislodging.

16716

ITEM No. 16716
 Applied to Right Hinged Base Door
 on All Model 1433 and Model 3334
 with Lower Removable Wheel

ITEM No. 708: ALL SAWS
 Attached to saw Guard
 on Saw Guide Bar

**ALWAYS
LOWER
GUARD
TO
HEIGHT
OF
PRODUCT**



**D
A
N
G
E
R**

**E
X
P
O
S
E
D
B
L
A
D
E**



ITEM No. 708

WARNING LABEL LOCATIONS ON MACHINE

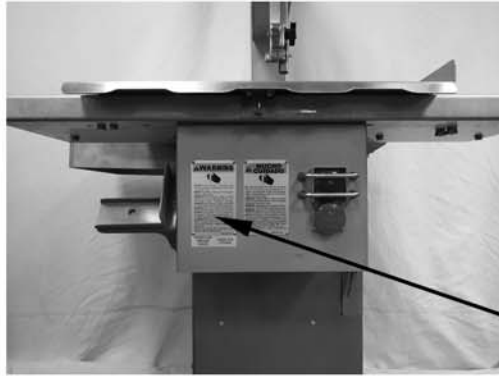

ATTACH TO CHANNEL BRACKET NEXT TO SWITCH BUTTONS



ATTACH ON HEAD STRUCTURE BELOW MODEL/SERIAL NUMBER TAG

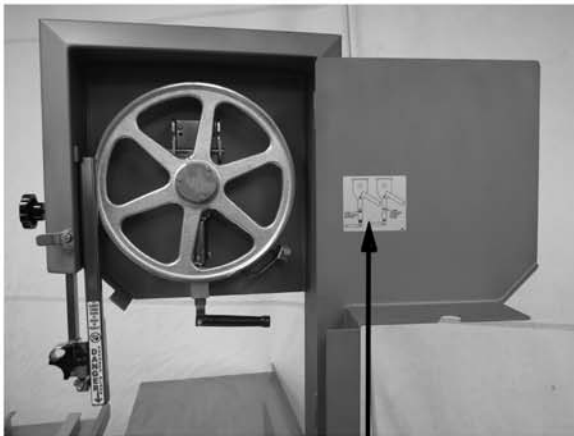

P/N 720 BLADE TENSION ADJUSTMENT DECAL

LOCATED INSIDE HEADDOOR

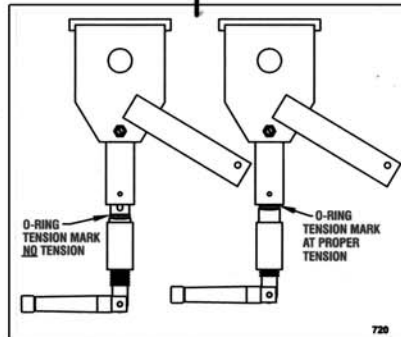

P/N 708 "DANGER EXPOSED BLADE" DECAL

ATTACHED TO SAW GUARD ON SAW GUIDE BAR

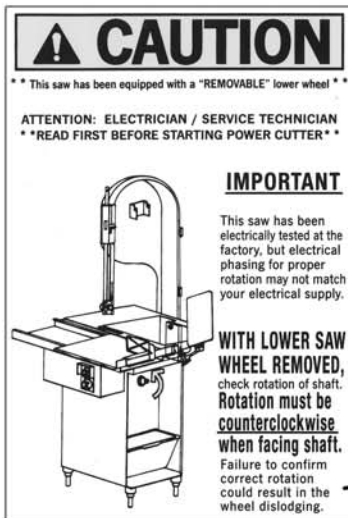

P/N 16716 "CAUTION" LABEL USE ON MACHINES WITH REMOVABLE LOWER WHEEL

ATTACH TO HINGED RIGHT BASE DOOR



ITEM NUMBER 671
WALL CHART "BAND SAW SAFETY GUIDELINES"
ATTACH TO WALL IN VICINITY OF MACHINE IN EASY VIEW OF OPERATOR



WARNING

ONLY PROPERLY TRAINED PERSONNEL SHOULD USE THIS EQUIPMENT

**This Saw Contains A Sharp Blade.
To Reduce Risk of Injury:**

1. Before Using, Make Sure:

- Gauge Plate (A) And Other Components Are Secure.
- All Warning Labels And Guards Are In Place.
- The Guide Bar (B) Is Adjusted To 1/2 Inch Above The Product To Be Cut

2. While Cutting:

- Keep Hands and Fingers Away From Blade.
- Keep Product Securely Against Gauge Plate.
- Use End Cut Pusher (C) When Making Final Cuts. Item No. 256P.

3. Before Cleaning:

- Turn Off Power and Unplug.
- Remove Saw Blade.
- Use Extra Care When Handling The Saw Blade.

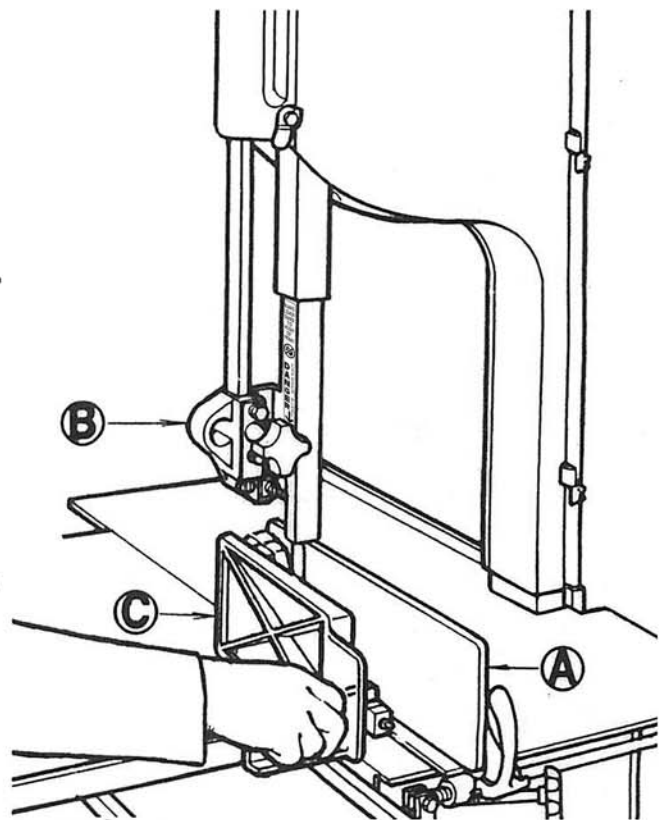

USE YOUR MEAT SAW SAFELY!

SEE PARTS AND SERVICE MANUAL SUPPLIED WITH MACHINE FOR ADDITIONAL SAFETY INFORMATION.

OPERATION



SHARP MOVING BAND TYPE SAW BLADE TO AVOID SERIOUS PERSONAL INJURY

ONLY Properly Trained Personnel Should Use This Equipment.

*ALWAYS Read Operating and Parts Manual **BEFORE** Operating.*

ALWAYS Keep Hands Clear of Band Type Saw Blade and Other Moving Parts.

DO NOT Tamper With, Bypass, Alter, or Modify this Equipment in Any Way or Form.

DO NOT Alter or Modify This Machine in any Way From its Original Form. This Machine in its Original Form Meets the Intent of O.S.H.A. Applicable Standards.

NEVER Operate with Saw Guard on Saw Guide Bar in the Raised Position or the Saw Guard Removed from the Saw Guide Bar.

ALWAYS Adjust the Saw Guide Bar with Saw Guard to Within $\frac{1}{2}$ " of Product to be Cut.

ALWAYS Use Safety End Cut Pusher Plate for Smaller Products or The Last Cuts of Product.

DO NOT Use This Machine for Non-Food Products.

DO NOT Use This Machine to Cut Pigs Feet.

DO NOT Wear Gloves While Operating.

ALWAYS Turn Off, Unplug from Power Source and Perform Lockout/Tag Out Procedures Before Cleaning, Servicing or When Not in Use.

NEVER Leave Machine Unattended While The Saw is Running.

NEVER Operate Without All Warning Labels Properly Affixed to Machine.

A. FOOD HANDLING TO PREVENT CONTAMINATION

1. **ALWAYS** wash hands thoroughly with warm soap and water before and after handling raw fish, poultry or meats.
2. **ALWAYS** clean and sanitize all utensils and surfaces that have been in contact with raw products.
3. **ALWAYS** store cold foods at or below 45 deg. F (7.2 deg. C).

B. TO PROCESS PRODUCT

1. Before starting power cutter, adjust saw guide bar with saw guard to within 1/2" of product to be cut. "B"

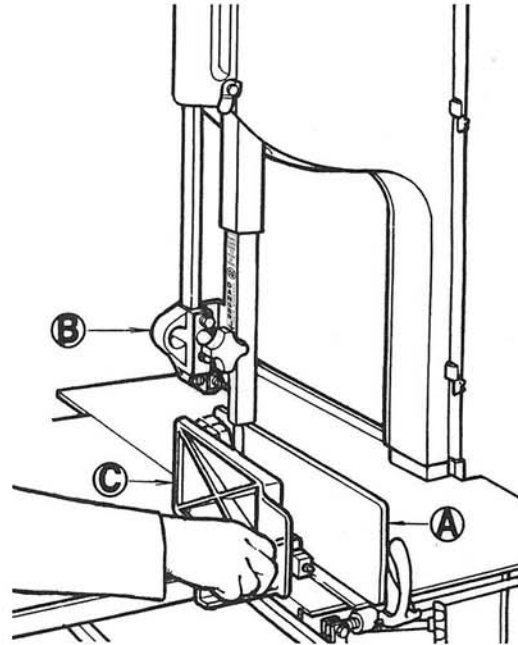
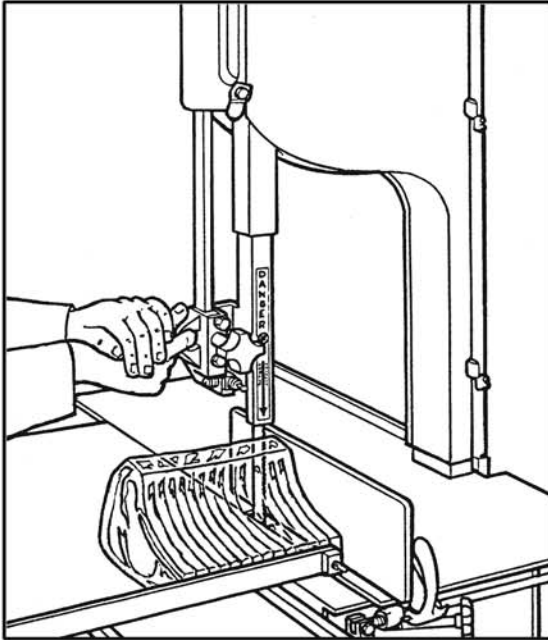

DO NOT WEAR GLOVES WHILE OPERATING

2. Make sure all doors are closed and locked.
3. Adjust meat gauge plate forward to desired thickness of cut. "A"
4. Push start button and watch blade for proper tracking.
5. Standing in front of the power cutter, place product on the meat carriage. Pay attention to position of your hands. Keep hands clear of moving band type saw blade. Leaning lightly against the scalloped front edge of meat carriage, hold the product firmly in right hand with product face flush against the meat gauge plate. Move the meat carriage from right to left at a steady rate until fully past the saw blade. Use left hand to remove and stack cut product, **NEVER REACH IN FRONT OF BAND TYPE SAW BLADE**. On the return stroke, pull the product slightly toward you to clear the blade.



NEVER REACH OR GRAB FOR PRODUCT IN FRONT OF MOVING BAND TYPE SAW BLADE

6. ALWAYS use the Safety End Cut Pusher Plate for smaller products or the last cuts of product. "C" The pusher plate is supplied as standard on all BIRO power cutters.
7. When finished cutting, push stop button. Perform lockout/tag out procedure.

MAINTENANCE



TO AVOID SERIOUS PERSONAL INJURY

ALWAYS Turn Off, Unplug From Power Source and Perform Lockout/Tag Out Procedure to This Machine **BEFORE** Cleaning or Servicing.

NEVER Touch This Machine Without Training and Authorization By Your Supervisor.

ALWAYS Keep Hands Clear of Band Type Saw Blade and Other Moving Parts.
NEVER Bypass, Alter, or Modify This Equipment in Any Way From Its Original Condition.
PROMPTLY REPLACE Any Worn or Illegible Warning Labels.
USE ONLY GENUINE BIRO Parts and Accessories Properly Installed.

A. GENERAL

1. Machine should be generally inspected every time it is cleaned (at least daily) to ensure that it is in good condition and has not been damaged or tampered with.
 - a. SAW WHEELS: Clean outer diameter grooves daily. Check for cracks, gouges or wear on the flange and grooves.
 - b. WHEEL CLEANER ASSEMBLIES: Check condition of fiber cleaner, change every four (4) weeks.
 - c. REMOVABLE FINGER LIFT ASSEMBLY: Check condition of saw guard, make sure mounting bolts are tight and the "DANGER EXPOSED BLADE" decal is affixed and legible. Check condition of upper saw guide, replace every 6 months. Check adjustment of upper saw guide. Should be 1/32" between back of blade and saw guide carbide.
 - d. SAW GUIDE BAR: Check condition of bar for wear, replace if necessary.
 - e. STATIONARY BAR ASSEMBLY: Check condition of nylon filler, change every 4 weeks. Check condition of saw guide, check tracking of blade through guide, back of blade should be centered in hole, replace every 6 months.
 - f. SAW CLEANERS: Check condition of blade cleaners, replace every 4 weeks.
 - g. MEAT GAUGE ASSEMBLY: Check free movement of meat gauge plate on gear rack. Gear rack to be kept lubricated at all times with light food grade oil. Check operation of release handle. Check that worm gear engages properly with gear rack.
 - j. MEAT CARRIAGE ASSEMBLY: Check free movement through full range of travel. Check side to side for excessive clearance, adjust as necessary. Check condition of and grease bearings, replace as necessary. Check condition of thumb guard, replace as necessary.
 - k. SAFETY ITEMS: Safety end cut pusher plate is with machine and accessible. All warning labels are present and legible. Model and Serial Number plate is affixed and legible. Manual accessible to operator.

B. LUBRICATION

1. **UPPER WHEEL BEARINGS:** Grease every four (4) months. Change grease every twelve (12) months. (See instructions at right.)
2. **LOWER BEARING HOUSING:** Grease every four (4) months. Change grease every twelve (12) months.
3. **MEAT CARRIAGE BEARINGS:** Grease every four (4) weeks.
4. **SAW GUIDE BAR:** Oil daily with food machine oil.
5. **MEAT GAUGE GEAR RACK:** Oil daily with food machine oil.
6. **BLADE TENSION SPRING SCREW ASSEMBLY:** Grease every 4 weeks –
 NOTE: Remove upper wheel and turn #14782 Blade Tension screw clockwise until it bottoms out against #14781 Blade Tension Handle then fill the cavity under the O-Ring on the #14782 Blade Tension Screw with #374 Shell Cassida Grease EPS-2 and re-assemble.
7. **MOTOR BEARINGS:** Bearing grease will lose its lubricating ability over time, not suddenly. The lubricating ability of a grease (over time) depends primarily on the type of grease, the size of the bearing, the speed at which the bearing operates and the severity of the operating conditions. Good results can be obtained if the following recommendations are used in your maintenance program.

**USE BIRO No. 374 GREASE FOR RE-GREASING
 SEE INSTRUCTIONS BELOW**

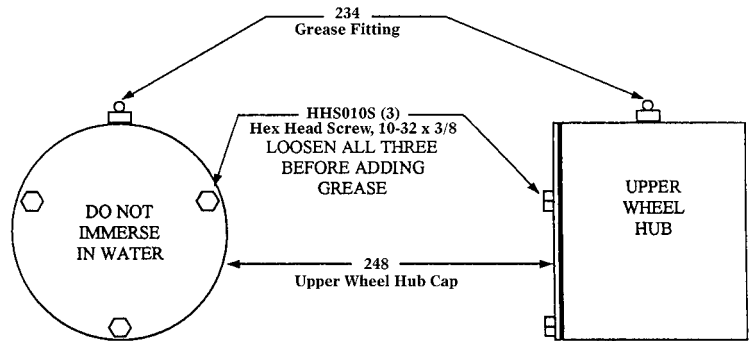

When lubricating the upper wheel bearing it is important that the three hex head screws securing the upper wheel hub cap be loosened slightly before attempting to pump grease into the grease fitting. Loosening the screws allows for an escape of old broken down grease and air from the bearing cavity. Failure to loosen the screws before greasing the upper bearings can cause the upper shaft seal to be dislodged from the upper wheel allowing grease to escape and moisture to get into the cavity. When finished greasing the bearings, retighten the three screws. Take care to also clean off any grease that was pushed out of the cavity during greasing.

A high grade ball or roller bearing grease should be used. recommended grease for standard service conditions is Polyrex EM (Exxon Mobil).

Equivalent and compatible greases include: Texaco Polystar, Rykon Premium #2, Pennzoil Pen 2 Lube, and Chevron SRI.

Recommended lubrications intervals is every 9 months with the equivalent of two (2) teaspoons of grease.

**NOTE:
ALWAYS REPORT MACHINE SERIAL
NUMBER WHEN ORDERING PARTS**

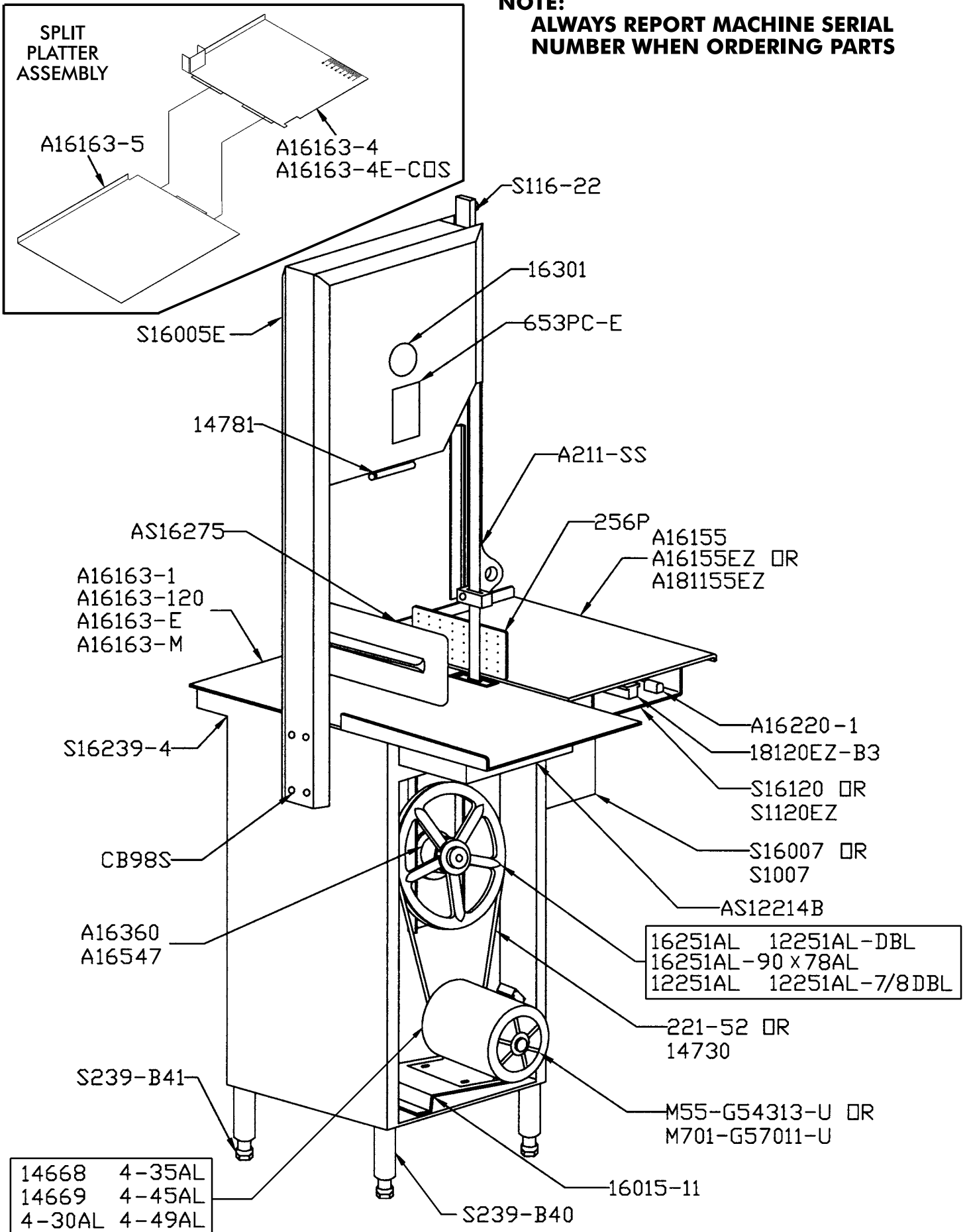

16251AL	12251AL-DBL
16251AL-90x78AL	
12251AL	12251AL-7/8DBL

14668	4-35AL
14669	4-45AL
4-30AL	4-49AL

NOTE:
ALWAYS REPORT MACHINE SERIAL
NUMBER WHEN ORDERING PARTS

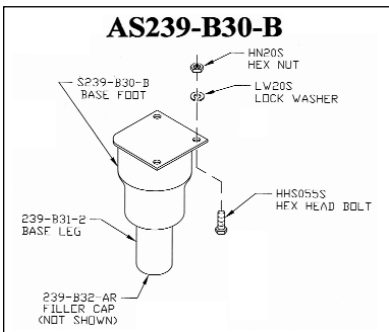
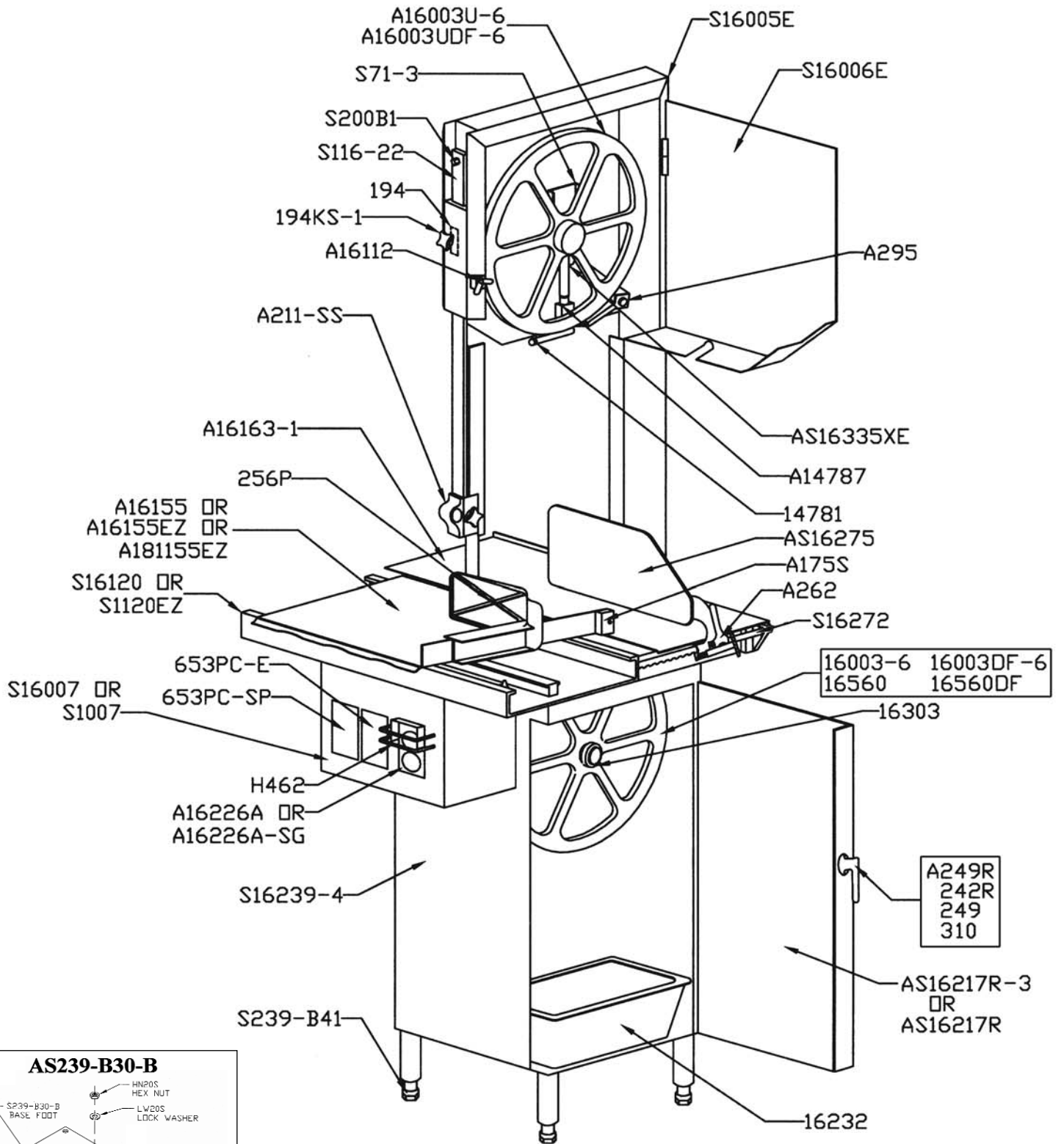

**MODEL 3334FH
SERIES OPTION:
FIXED HEAD &
DOOR ASSEMBLY, SS**

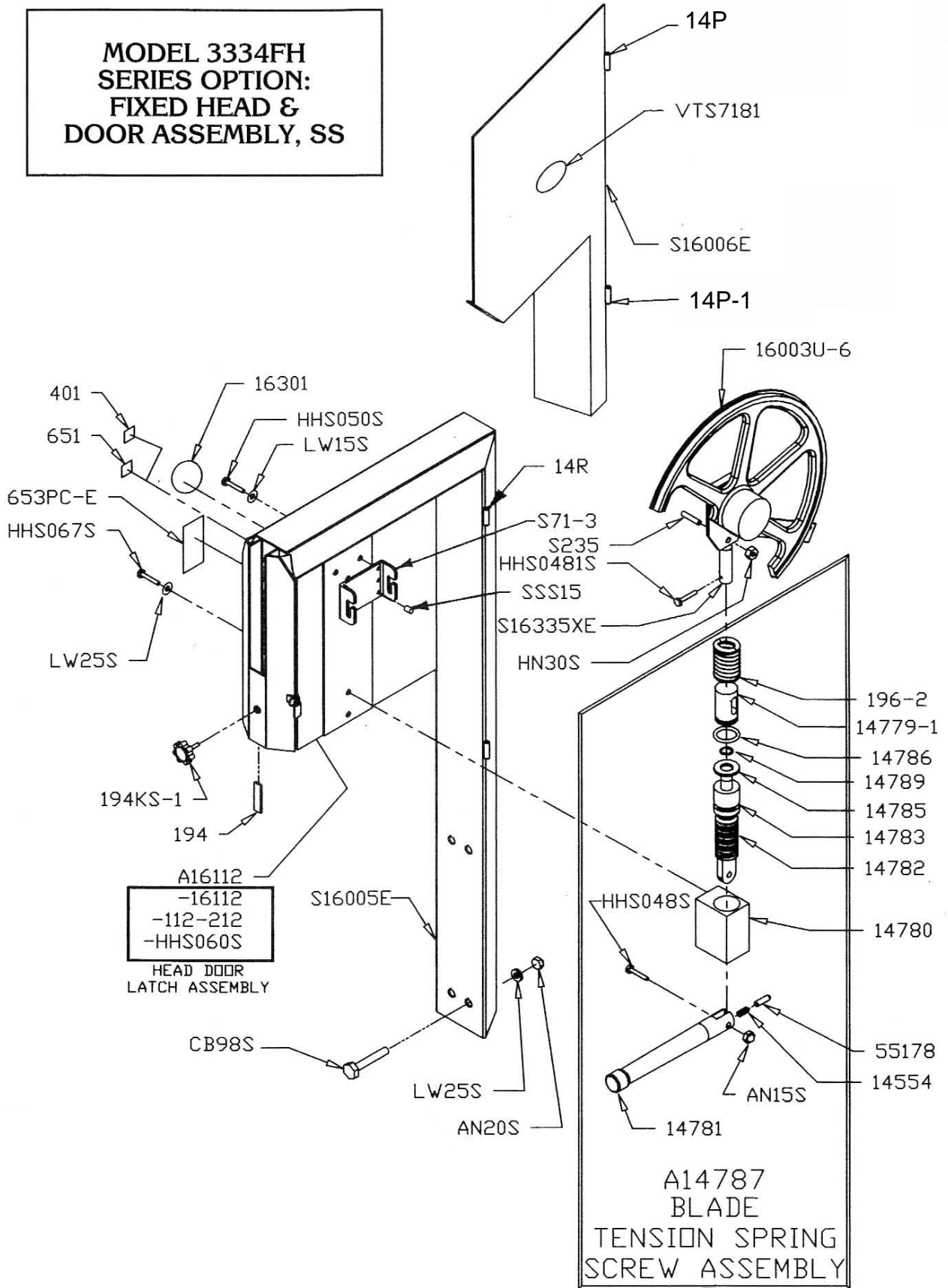

**MODEL 3334
FIXED HEAD &
DOOR ASSEMBLY, S.S.
W/PUSHBUTTON SWITCH**

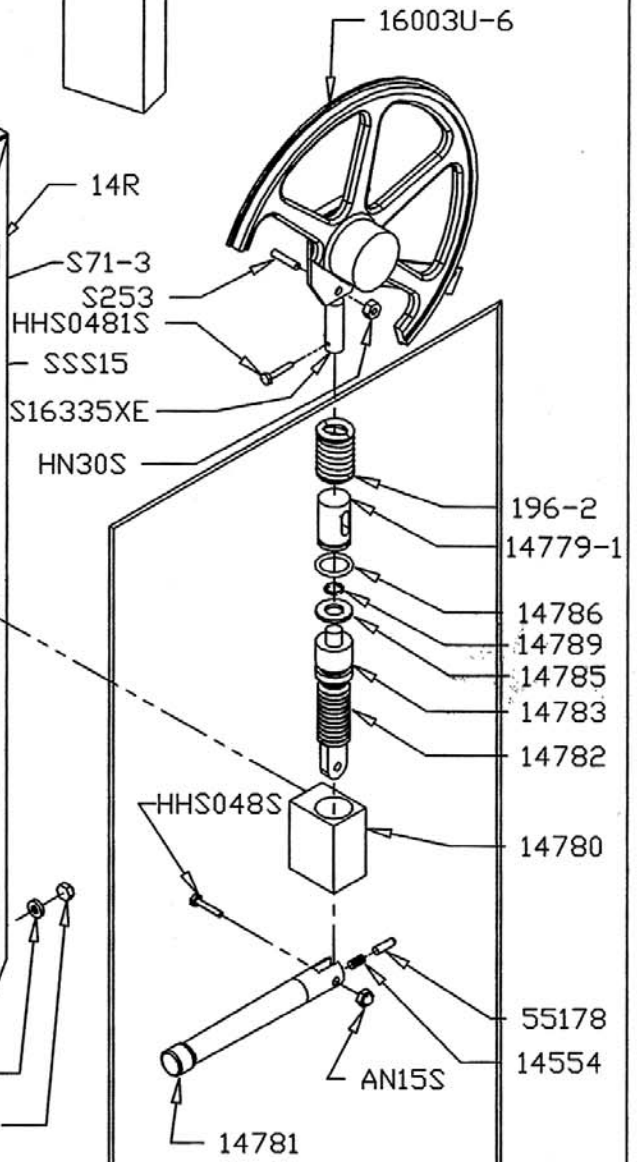
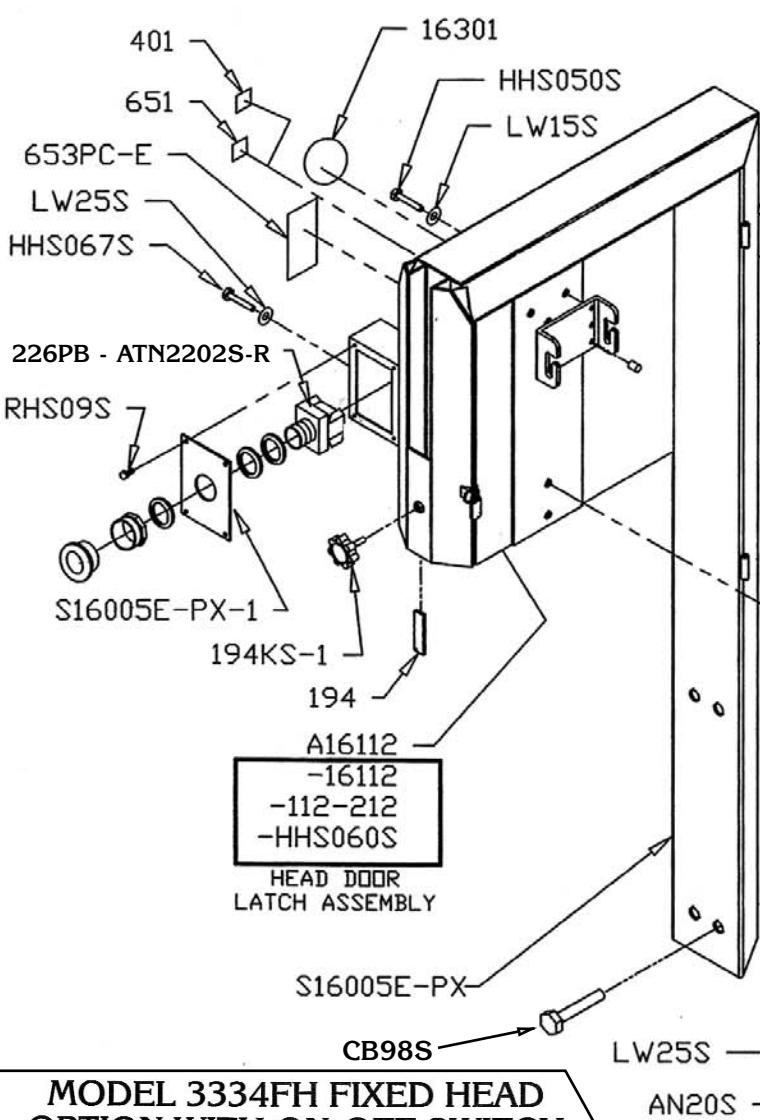
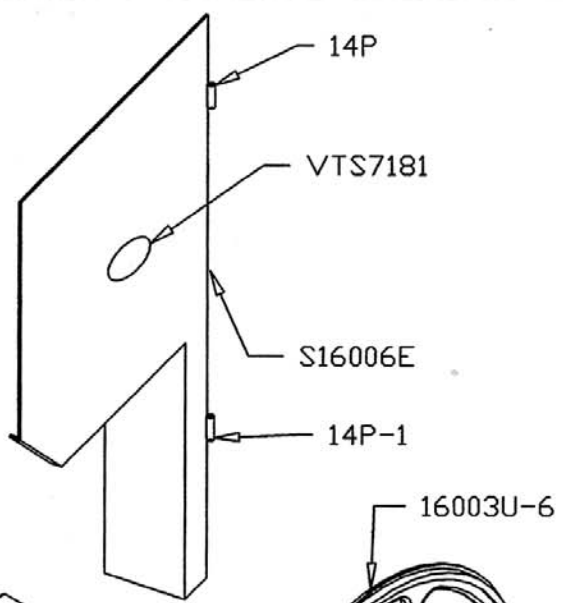

**A14787
BLADE
TENSION SPRING
SCREW ASSEMBLY**

**MODEL 3334FH FIXED HEAD
OPTION WITH ON-OFF SWITCH
LOCATED ON HEAD WELDMENT**

Part No.	Description
S16005E-PX	Head, fixed with pushbutton control box
226PB - ATN2202S-R	Pushbutton switch 3-pos MOM in & out
S16005E-PX-1	Switch cover with gasket
RHS09S	Round head screw 10-32 x 3/8, SS

ITEM No.: 14782K Blade Tension Screw Conversion Kit

INSTALLATION INSTRUCTIONS

Disconnect the machine from main power supply.

Loosen tension on the saw blade and remove the upper wheel assembly

Unbolt the (A) tensioning handle from the (B) blade tension screw.

At the bottom handle mount turn the (B) blade tension screw clockwise until it can be lifted out of the (C) housing.

Apply a good food grade grease to the replacement (D) tension screw and install into the (C) housing turning counterclockwise until it bottoms out.

Replace the (A) tensioning handle. Be sure the (E) spring and (F) plunger pin are still present in the end of the (A) handle.

Replace the upper wheel assembly and the blade.

Tension the blade.

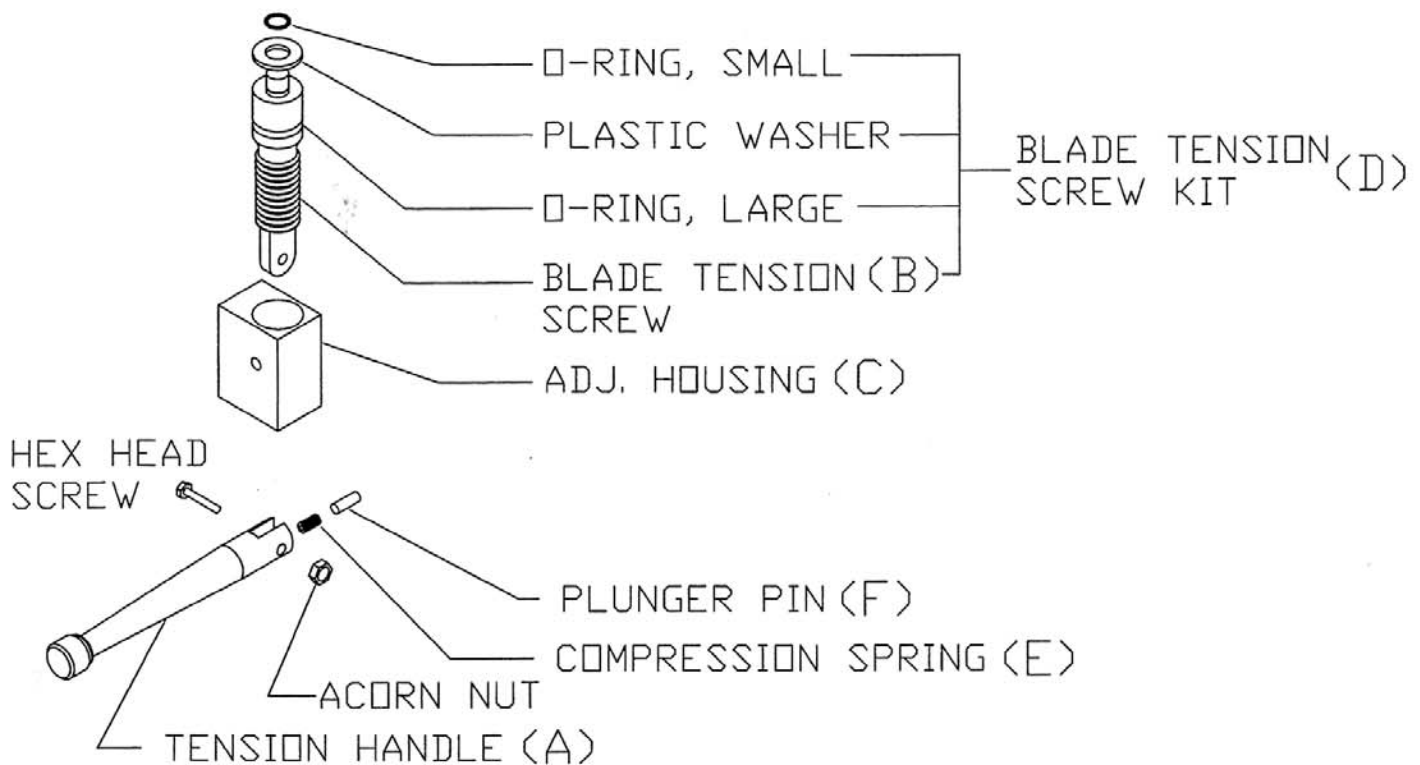

(A)	14781	Tension Handle
(B)	14782	Blade Tension Screw
(C)	14780	Adjustment Housing
(D)	14782K	Blade Tension Screw Kit
(E)	14554	Compression Spring
(F)	55178	Plunger Pin

14783	O-Ring, Large
14785	Plastic Washer
14789	O-Ring, Small
AN15S	Acorn Nut, 1/4-20
HHS048S	Hex Head Screw 1/4-20 x 1 1/4

– OPERATOR’S NOTES –

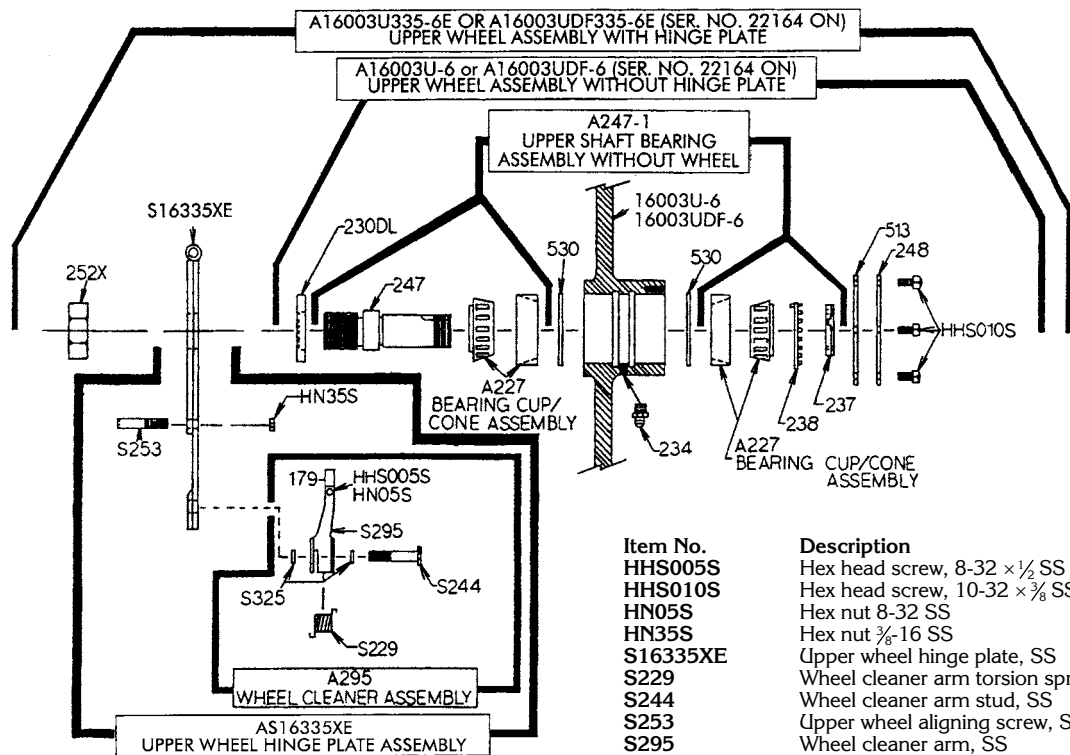

Item No.	Description
A16003U-6	Upper wheel assembly without hinge plate
A16003U335-6E	Upper wheel assembly with hinge plate
A16003UDF-6	Upper double flange wheel assembly without hinge plate
A16003UDF335-6E	Upper double flange wheel assembly with hinge plate
A247-1	Upper shaft bearing assembly
AS16335XE	Upper wheel hinge plate assembly
A227	Bearing cup/cone assembly
A295	Wheel cleaner assembly

Item No.	Description
HHS005S	Hex head screw, 8-32 x 1/2 SS
HHS010S	Hex head screw, 10-32 x 3/8 SS
HN05S	Hex nut 8-32 SS
HN35S	Hex nut 3/8-16 SS
S16335XE	Upper wheel hinge plate, SS
S229	Wheel cleaner arm torsion spring, SS
S244	Wheel cleaner arm stud, SS
S253	Upper wheel aligning screw, SS
S295	Wheel cleaner arm, SS
S325	Wheel cleaner washer, SS
16003U-6	Upper wheel, 16", 6 spoke
179	Wheel cleaner
230DL	Upper shaft seal, double lip
234	Grease fitting, upper wheel
237	Upper shaft castellated lock nut
238	Upper shaft castellated lock nut washer
247	Upper shaft
248	Upper wheel hub cap
252X	Shaft lock nut
513	Upper wheel hub gasket
530	Retaining ring (2 req.)

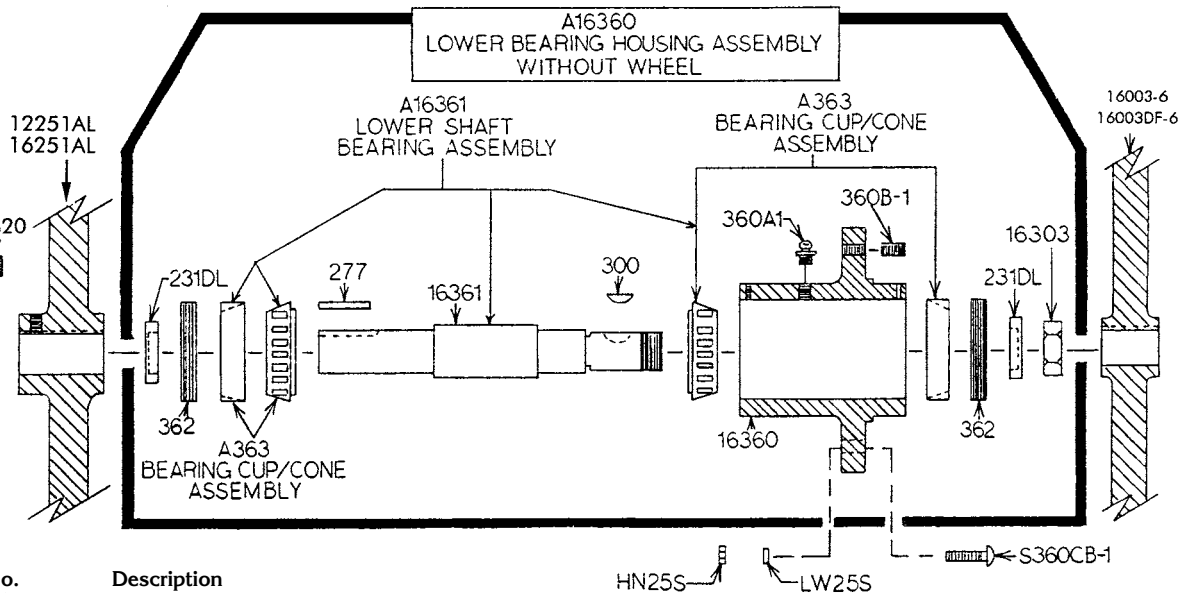

Item No.	Description
A16360	Lower bearing housing assembly without wheel
A16361	Lower shaft bearing assembly
A363	Lower Bearing cup/cone assembly
HN25S	Hex nut, 3/8-16 SS
LW25S	Lock washer, 3/8 SS
SSS20	Set screw, 3/8-16 x 3/8 cup point, SS
S360CB-1	Carriage bolt, 3/8-16 1 1/4 SS
12251AL	Upper V-belt pulley 9 x 1 AL
16003-6	Lower wheel 16", 6 spoke
16003DF-6	Lower double flange wheel 16", 6-spoke

Item No.	Description
16251AL	Upper v-belt pulley, 11.4 x 1 AL
16303	Lower shaft nut
16360	Lower bearing housing
16361	Lower shaft
231DL	Lower shaft seal, double lip
277	Lower shaft key
300	Lower shaft Woodruff key
360A1	Grease fitting
360B-1	Set screw, 1/2-13 x 1/2 flat point
362	Lower bearing housing adj. cap

A415D STATIONARY BAR ASSEMBLY

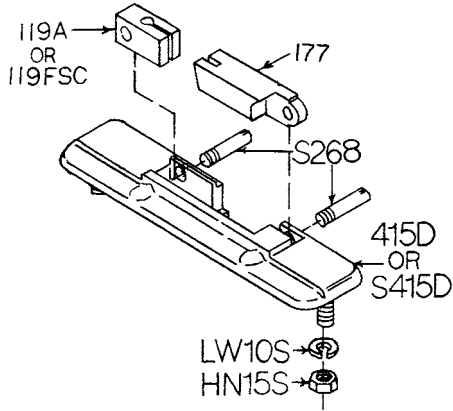

Item No.	Description
A415D	Stationary bar assembly
HN15S	Hex nut 1/4-20 SS
LW10S	Lock washer, 1/4 SS
S268	Stationary bar headless screw
119A	Saw guide in stationary bar
119FSC	Saw guide in stationary bar - fish
177	Nylon filler
415D	Stationary bar

A16132 REAR STEEL CLEANER ASSEMBLY

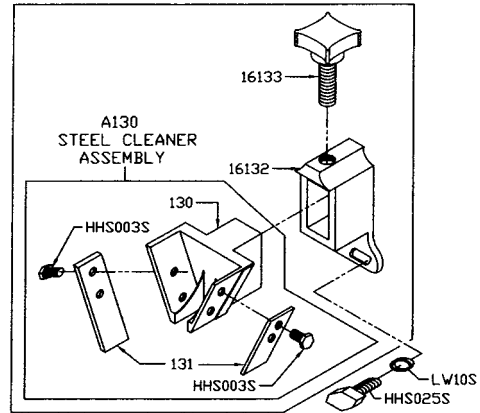

Item No.	Description
A130	Saw cleaner assembly
A16132	Steel cleaner assembly, rear
HHS003S	Trimmed hex head screw 8-32 x 1/4, SS
HHS025S	Hex head screw, 1/4-20 x 1/2 SS
LW10S	Lock washer, 1/4 SS
130	Saw cleaner bracket rear
131	Saw cleaner SS
16132	Saw cleaner bracket holder, rear
175-2-S	Thumb screw, 1/4-20 x 1/2
16133	Fastener knob - 4 point

AS16273-S275 MEAT GAUGE GEAR RACK & BRACKET ASSEMBLY

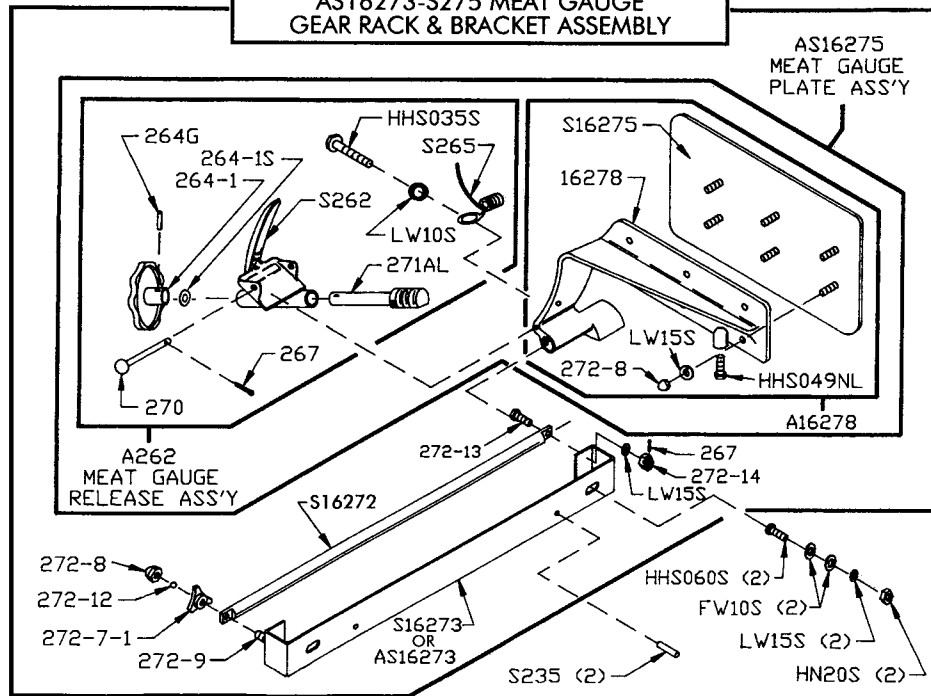

Item No.	Description
A16278	Meat gauge plate assembly less release assembly
A262	Meat gauge release assembly
AS16273	Meat gauge bracket assembly
AS16273-S275	Meat gauge assembly
AS16275	Meat gauge plate assembly with release assembly
FW10S	Flat washer, 5/16, SS
HHS035S	Hex head screw 1/4-20 x 5/8
HHS049NL	Hex head screw, 5/16-18 x 1/2, nylon
HHS060S	Hex head screw, 5/16-18 x 1, SS
HN20S	Hex nut, 5/16-18, SS
LW10S	Lock washer, 1/4, SS
LW15S	Lock washer, 5/16, SS
S16272	Meat gauge gear rack, stainless
S16273	Meat gauge bracket, SS
S16275	Meat gauge plate, SS

Item No.	Description
S235	Taper pin, 4 x 3/4, SS
S262	Meat gauge release handle, SS
S265	Meat gauge release spring
16278	Meat gauge arm
264G	Meat gauge hand wheel groove pin
264-1	Meat gauge hand wheel
264-1S	Hand wheel shim
267	Meat gauge release cotter key
270	Meat gauge release pin
271AL	Meat gauge worm gear, aluminum
272-7-1	Lock knob, 5/16-18, 3 point
272-8	Cap nut, 5/16-18 SS
272-9	Hex bolt, 5/16-18 x 2 SS
272-12	Brass ball
272-13	Hex head screw, 5/16-18 x 1 1/4, SS
272-14	Castellated nut, 5/16-18, SS

SAW GUIDE BAR ASSEMBLY

Item No.	Description
AS116-22SS	Saw guide bar assem. with lock knob 22" - stainless
A116-22SS	Saw guide bar assembly 22" - stainless
AS116-22-COS	Saw guide bar assembly - 22" SS special
A211-SS	Finger lift assembly, removable - stainless
A211-COS	Finger lift assembly - removable SS special
A602	Saw guide assembly, upper
FW05S	Flat washer, 1/4 SS
HHS015S	Hex head screw, 10-32 x 3/4 SS
HHS020S	Hex head screw, 1/4-20 x 3/8 SS
HHS083S	Hex head screw, 3/8-16 x 1 1/4 SS
HN10S	Hex nut, 10-32 SS
LH663	Saw guard for true left head
LW05S	Lock washer, #10 SS
LW10S	Lock washer, 1/4 SS
RHS10S	Round head screw, 10-32 x 3/4 SS
RHS30S	Round head screw, 1/4-20 x 3/8 SS
S200B1	Stop stud on guide bar
S116-22	Saw guide bar, 22"
S116-22-COS	Saw guide bar - 22" special
16662	Saw guard for SS head
16662-COS	Saw guard - special
17211-22	Finger lift, shim, .022
17211-35	Finger lift, shim, .035
193	Saw guide bar spring
194	Saw guide bar lock pad
194KS-1	Saw guide bar lock knob
211	Finger lift bracket
211A-291Q	Fastener knob, 4 point
601	Upper saw guide bracket
602B	Upper saw guide with carbide
602AFSC	Upper saw guide, narrow, fish
708	Decal "DANGER EXPOSED BLADE"

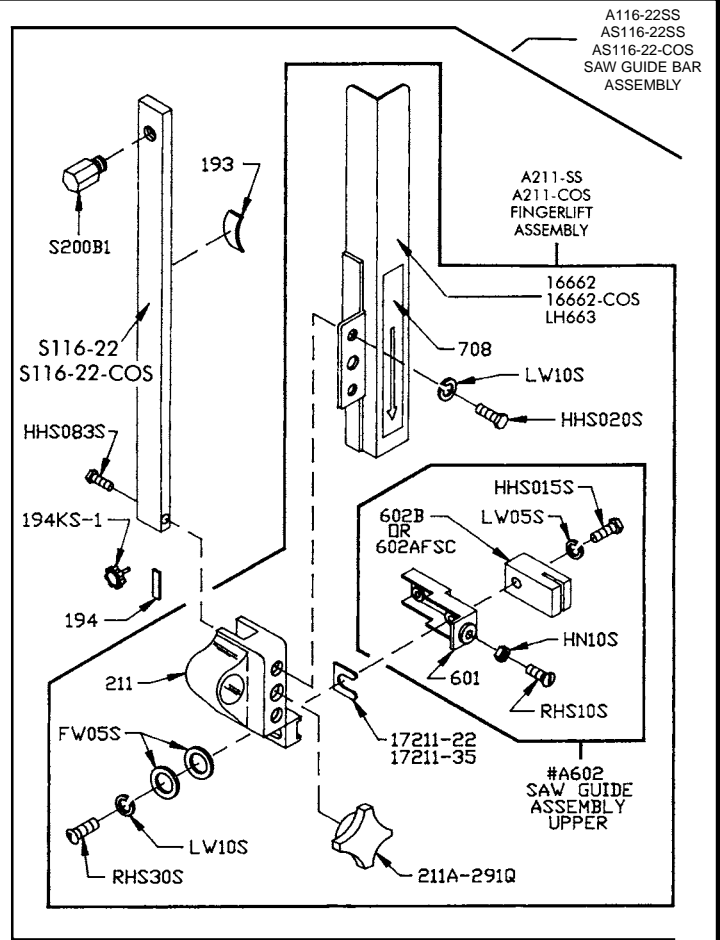

AS16290 CLEANING UNIT TOTAL ASSEMBLY

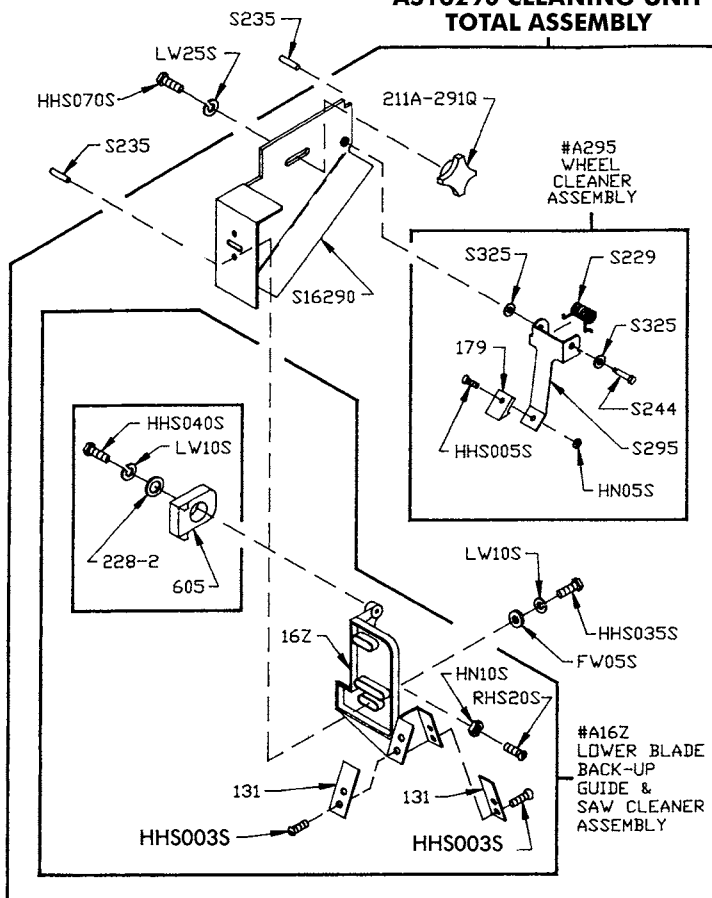

Item No.	Description
A16Z	Guide bracket saw cleaner assembly
A295	Wheel cleaner assembly
AS16290	Cleaning unit total assembly
FW05S	Flat washer, 1/4 SS
HHS003S	Trimmed hex head screw 8-32 x 1/4, SS
HHS005S	Hex head screw, 8-32 x 1/2 SS
HHS035S	Hex head screw, 1/4-20 x 5/8 SS
HHS040S	Hex head screw, 1/4-20 x 3/4 SS
HHS070S	Hex head screw, 3/8-16 x 1 SS
HN05S	Hex nut, 8-32 SS
HN10S	Hex nut, 10-32 SS
LW10S	Lock washer, 1/4 SS
LW25S	Lock washer, 3/8 SS
HHS003S	Hex head screw, 10-32 x 1/8 SS
RHS20S	Round head screw 10-32 x 1 1/8 SS
S16290	Cleaning unit stamping, SS
S229	Wheel cleaner arm torsion spring SS
S235	Taper pin 4 x 3/4, SS
S244	Wheel cleaner arm stud SS
S295	Wheel cleaner arm SS
S325	Wheel cleaner washer SS
131	Saw cleaner SS
16Z	Lower guide bracket saw cleaner holder
179	Wheel cleaner
211A-291Q	Fastener knob, 4 point
228-2	Lower guide washer
605	Saw guide lower blade back-up

STANDARD 3334FH MEAT CARRIAGE & CHANNEL

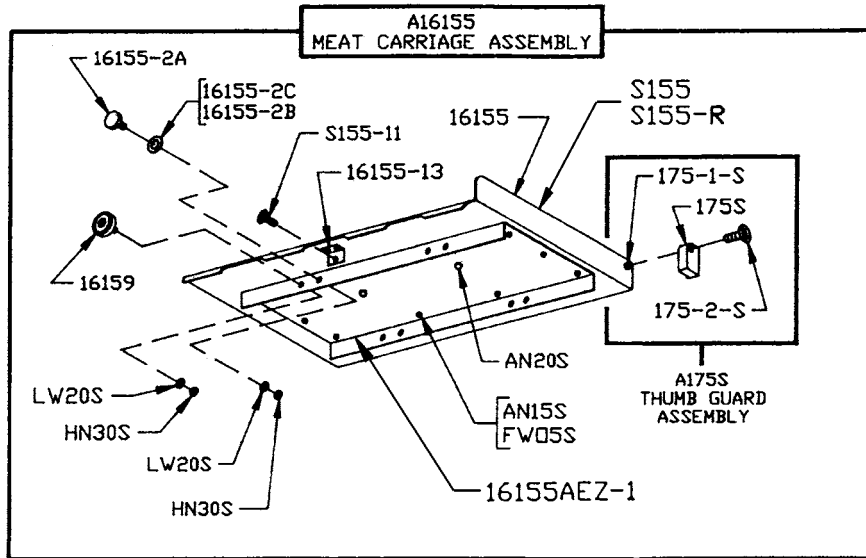

Item No.	Description
A16155	Meat carriage assembly complete
A175S	Thumb guard assembly
FW05S	Flat washer, 1/4 SS
AN15S	Acorn nut, 1/4-20 SS
AN20S	Acorn nut, 3/8-16 SS
HN30S	Hex nut, 3/8-16 light jam SS
LW20S	Lock washer 3/8 regular SS
S155-11	Meat carriage stop thumb screw
S155	Meat carriage top only (NSS)
S155-R	Raw meat carriage top only (DNS)

Item No.	Description
16155	Meat carriage top & angle only
16155-2A	Meat carriage guide
16155-2B	Meat carriage guide spacer, 1/4TK
16155-2C	Meat carriage guide spacer, 1/2TK
16155-13	Carriage stop angle SS, welded
16155AEZ-1	Meat carriage angle plate (DNS)
16159	Meat carriage bearing SS
175S	Thumb guard, nylon
175-1-S	Thumb guard nut SS
175-2-S	Thumb screw 1/4-20 x 1/2

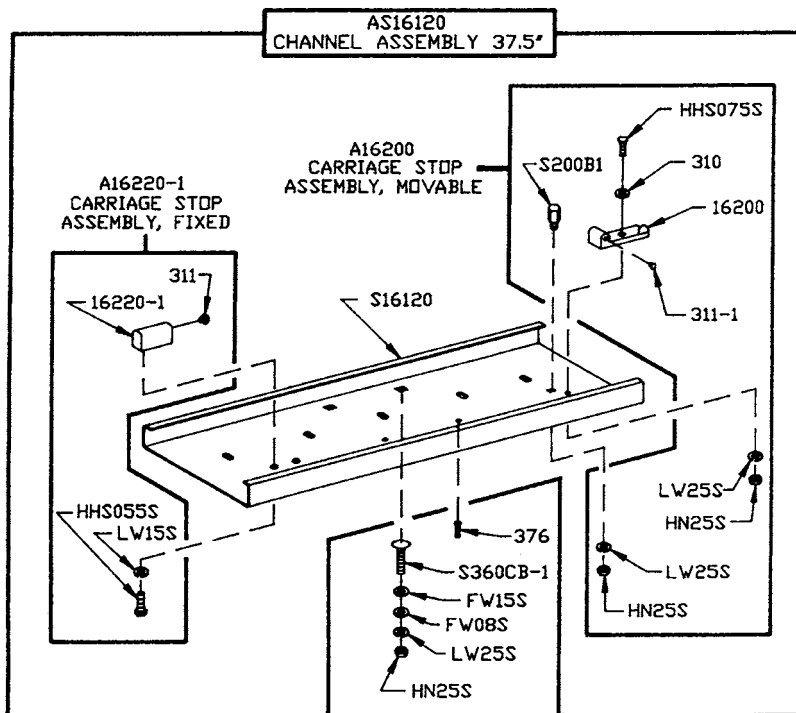

Item No.	Description
A16200	Carriage stop assembly, movable
A16220-1	Carriage stop assembly, fixed
AS16120	Channel assembly, 37"
FW08S	Flat washer, 3/8 SS
FW15S	Flat washer, 1/2 SS
HHS055S	Hex head screw, 5/16-18 x 3/4 SS
HHS075S	Hex head screw, 3/8-16 x 1 1/4 SS
HN25S	Hex nut, 3/8-16 SS
LW15S	Lock washer, 5/16 SS
LW25S	Lock washer, 3/8 SS

Item No.	Description
S16120	Channel, 37" SS
S200B1	Stop stud SS, guide bar & carriage stop
S360CB-1	Carriage bolt, 3/8-16 x 1 1/4 SS
16200	Carriage stop, movable
16220-1	Carriage stop, fixed
310	Waved washer
311	Rubber bumper, fixed stop
311-1	Rubber bumper, movable stop
376	Drive screw 10 x 1/2 SS

OPTIONAL 3334FH EZ FLOW MEAT CARRIAGE & CHANNEL

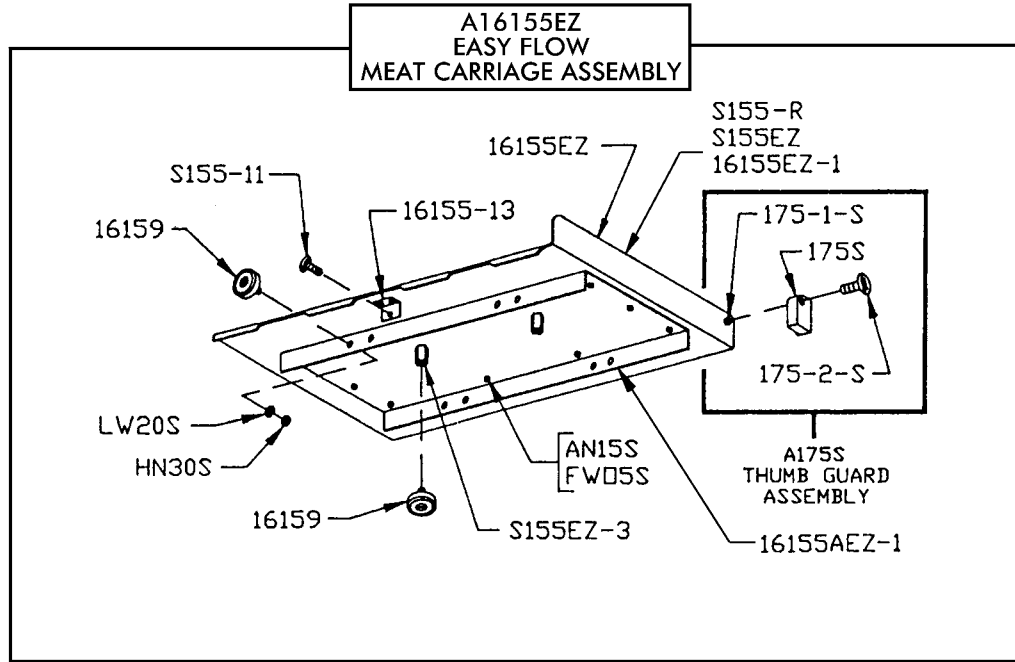

Item No.	Description	Item No.	Description
A16155EZ	Meat carriage assembly complete – EZ Flow	S155EZ-3	Hex stand-off, EZ Flow carriage
A175S	Thumb guard assembly	16155EZ	Meat carriage top & angle only
FW05S	Flat washer, 1/4 SS	16155EZ-1	Meat carriage top only w/weld studs (DNS)
AN15S	Acorn nut, 1/4-20 SS	16155-13	Carriage stop angle SS
HN30S	Hex nut, 3/8-16 light jam SS	16155AEZ-1	Meat carriage angle plate
LW20S	Lock washer 3/8 regular SS	16159	Meat carriage bearing SS
S155-11	Meat carriage stop thumb screw	175S	Thumb guard, nylon
S155-R	Raw meat carriage top only (DNS)	175-1-S	Thumb guard nut SS
S155EZ	Meat carriage top only (NSS)	175-2-S	Thumb screw 1/4-20 x 1/2, SS

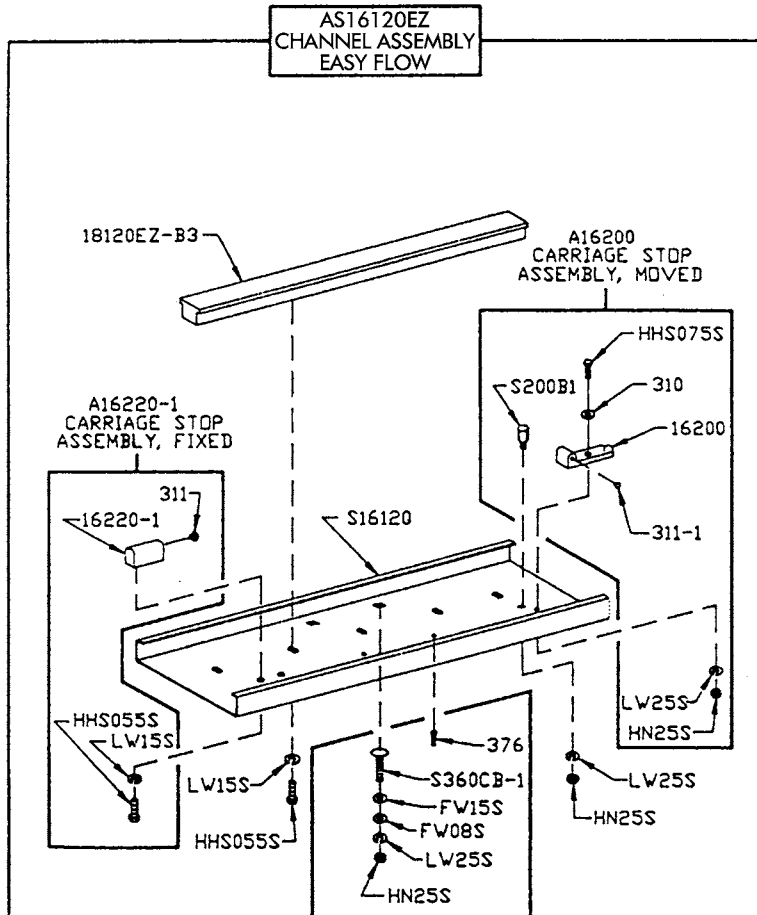

Item No.	Description
A16200	Carriage stop assembly, movable
A16220-1	Carriage stop assembly, fixed
AS16120EZ	Channel assembly, 37" – EZ Flow
FW08S	Flat washer, 3/8 SS
FW15S	Flat washer, 1/2 SS
HHS055S	Hex head screw, 3/16-18 x 3/4 SS
HHS075S	Hex head screw, 3/8-16 x 1 1/4 SS
HN25S	Hex nut, 3/8-16 SS
LW15S	Lock washer, 3/16 SS
LW25S	Lock washer, 3/8 SS
S16120	Channel, 37" SS
S200B1	Stop stud SS, guide bar & carriage stop
S360CB-1	Carriage bolt, 3/8-16 x 1 1/4 SS
16200	Carriage stop, movable
16220-1	Carriage stop, fixed
18120EZ-B3	Guide bar – EZ Flow
310	Waved washer
311	Rubber bumper, fixed stop
311-1	Rubber bumper, movable stop
376	Drive screw 10 x 1/2 SS

**STANDARD 3334-4003FH EZ FLOW MEAT CARRIAGE & CHANNEL
ALSO OPTIONAL ON ALL OTHER 3334**

**A181155EZ
MEAT
CARRIAGE
ASSEMBLY
EZ FLOW**

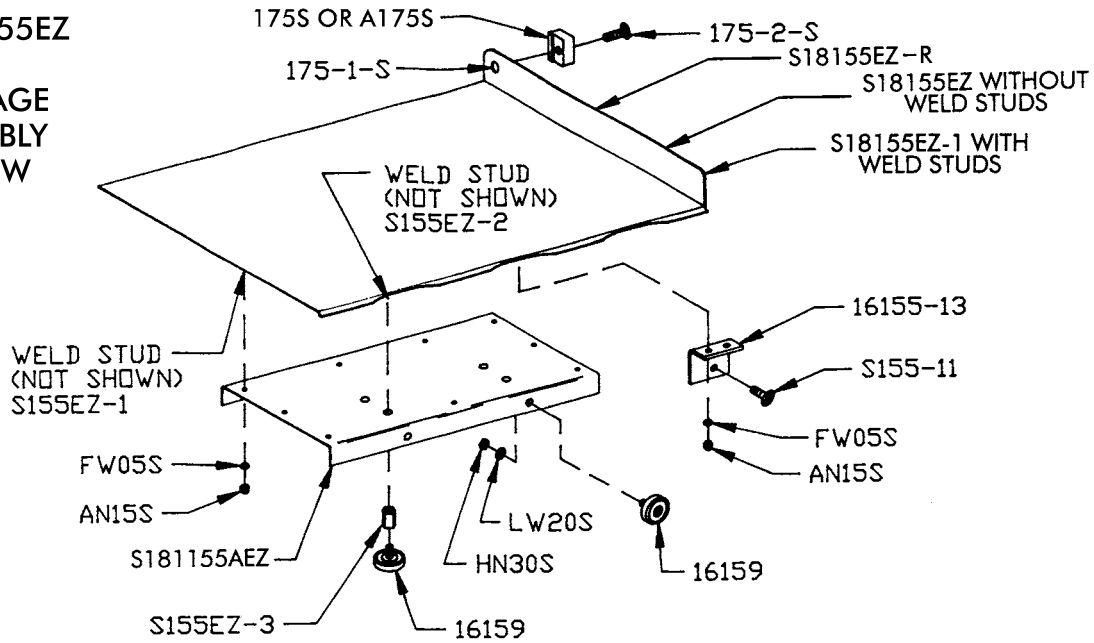

Item No.	Description
A175S	Thumb guard assembly
A181155EZ	Meat carriage assembly, EZ Flow
AN15S	Acorn nut, 1/4-20
FW05S	Flat washer, 1/4
HN30S	Hex nut, 3/8-16 light jam
LW20S	Lock washer, light
S155-11	Carriage stop thumb screw
S155EZ-1	Weld stud - NSS
S155EZ-2	Weld stud - NSS

Item No.	Description
S181155AEZ	Meat carriage angle - EZ Flow
S18155EZ-1	Carriage top w/weld studs
S18155EZ	Carriage top without weld studs
S18155EZ-R	Raw carriage top only (DNS)
S155EZ-3	Hex stand-off - EZ Flow carriage
16155-13	Carriage stop angle SS
16159	Carriage bearing
175S	Thumb guard - nylon
175-1-S	Thumb guard nut, SS
175-2-S	Thumb screw 1/4 x 1/2, SS

**AS1120EZ
CHANNEL
ASSEMBLY
EZ FLOW**

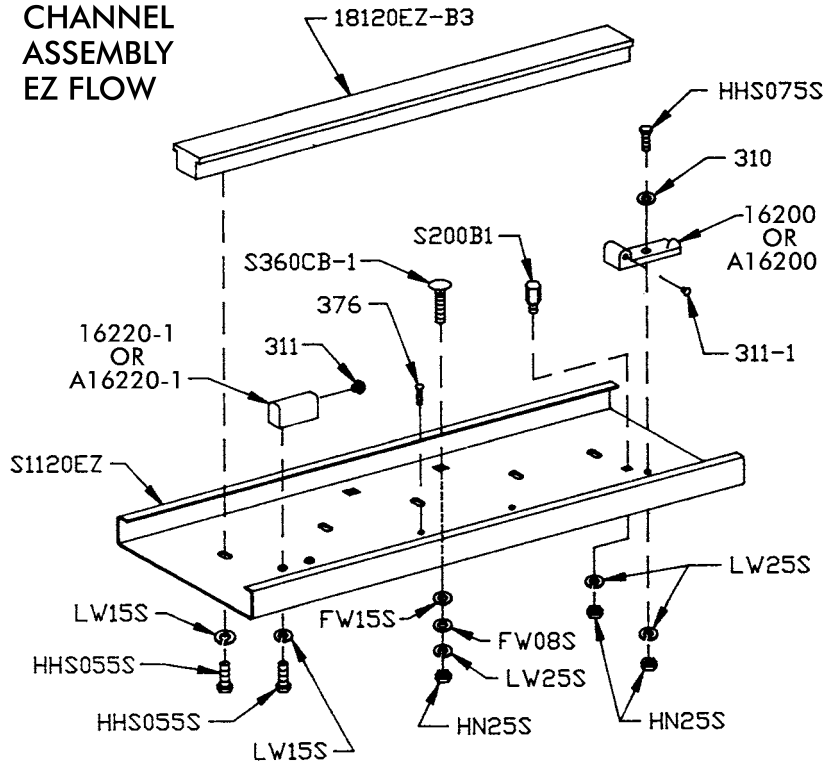

Item No.	Description
A16200	Carriage stop assembly, movable
A16220-1	Carriage stop assembly, fixed
AS1120EZ	Channel assembly, EZ Flow
FW08S	Flat washer, 3/8 SS
FW15S	Flat washer, 1/2 SS
HHS055S	Hex head screw, 5/16-18 x 3/4 SS
HHS075S	Hex head screw, 3/8-16 x 1 1/4 SS
HN25S	Hex nut, 3/8-16 SS
LW15S	Lock washer, 5/16 SS
LW25S	Lock washer, 3/8 SS
S1120EZ	Channel, EZ Flow
16200	Carriage stop - movable
16220-1	Carriage stop - fixed
18120EZ-B3	Guide bar, EZ Flow
S200B1	Stop stud, SS
310	Waved washer
311	Rubber bumper - fixed stop
311-1	Rubber bumper - movable stop
376	Drive screw #10 x 1/2
S360CB-1	Carriage bolt, 3/8-16 x 1 1/4 SS
NOT SHOWN	
S1007	Channel bracket, SS

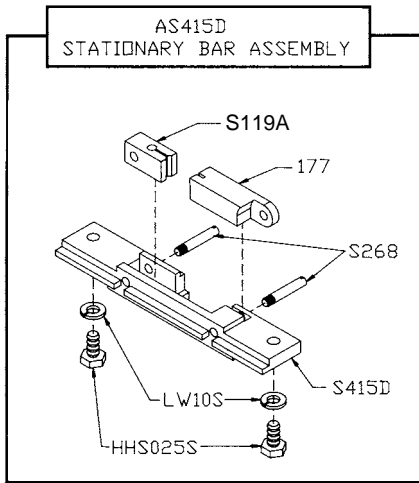

Item No.	Description
AS415D	Stationary bar assembly SS
HHS025S	Hex head screw, 1/4-20 x 1/2 SS
LW10S	Lock washer, 1/4 SS
S268	Stationary bar headless screw
S119A	Saw guide in stationary bar-stainless steel
177	Nylon filler
S415D	Stationary bar SS

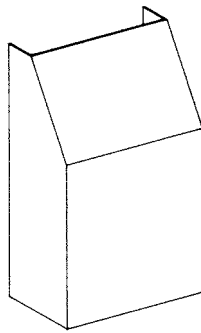

S16217LTP
Base Door, Left Tapered Panel, SS

S16217L
Base Door Left, SS

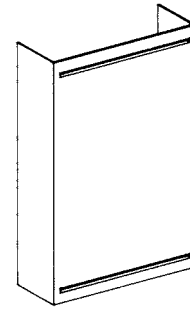

USE WITH

Motor Mfg.	Model No.	Specifications
Doerr	XR72927	1 1/2HP, 220/440-50/60-3 open
Doerr	R72929	2HP, 220/440-50/60-3 open
U.S. Motor	G54313	2HP, 220/440-50/60-3 open
Doerr	73020	2HP, 550-60-3 open
U.S. Motor	G57016	2HP, 550-60-3 open

USE WITH

Motor Mfg.	Model No.	Specifications
Doerr	73032	1 1/2HP, 115/230-50-1 open
U.S. Motor	G57347	1 1/2HP, 115/230-50-1 open
Doerr	72933	1 1/2HP, 115/230-60-1 open
Baldor	L3605	2HP, 115/230-60-1 TE
Baldor	L3605-50	2HP, 115/230-50-1 TE
Baldor	L1322T	2HP, 115/230-60-1 open
Doerr	67385	2HP, 208/220/440-50/60-3 TE
Baldor	M3558T-5	2HP, 550-60-3 TE
Baldor	M3558T-50	2HP, 220/380/415-50-3 TE
Baldor	M3558T-8	2HP, 200-60-3 TE
Doerr	72540	3HP, 220/440-50/60-3 TE
Doerr	75425	3HP, 220/440-50/60-3 TE
U.S. Motor	G57011	3HP, 220/440-50/60-3 TE
Baldor	M3611	3HP, 220/440-50/60-3 TE
Baldor	M3611T-50	3HP, 220/380/440-50-3 TE
Baldor	M3611T-8	3HP, 200-60-3 TE
Doerr	73031	5HP, 220/440-50/60-3 TE
Doerr	A907	5HP, 220/440-50/60-3 TE

MOTOR ADJUSTMENT

ADJUSTMENTS

- For tightening motor V-belt on rigid base plate, remove appropriate quantity of shims (Part No. 324A) under the motor until the desired total flex of the V-belt is approximately 1/2".
- For tightening motor V-belt on floating adjustable motor mounting plates (Part No. 16015-10 or 16015-11), loosen the upper wing nuts (Part No. 16015-3). Then loosen the bottom wing nuts (Part No. 16015-3) which are located under the mounting plate. This enables the motor mounting plate to drop to the desired belt tension. Re-tighten the upper wing nuts evenly so that the motor stays horizontal. Do not tighten belt to extremes. This will cause undue pressure on and premature failure of the motor bearings.

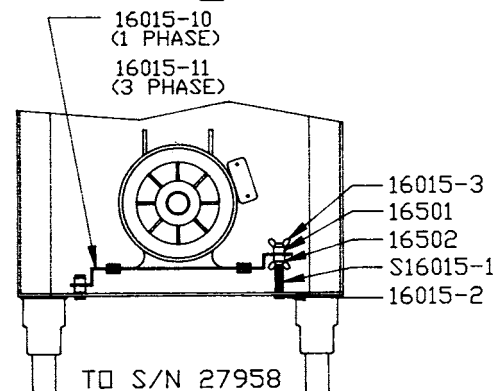
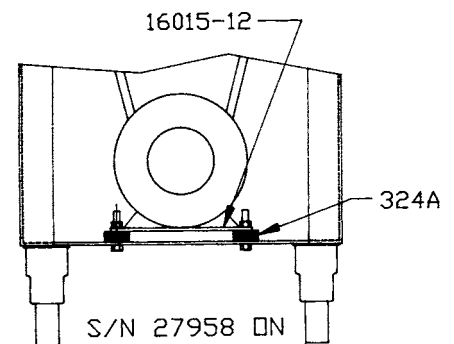

LONGER SAW GUARD KIT

Item No. 16662K

This longer guard is for replacement on existing saws. Install the new guard with the 1/4" dia. Screws supplied with the Saw Guard Kit, Item No. 16662K

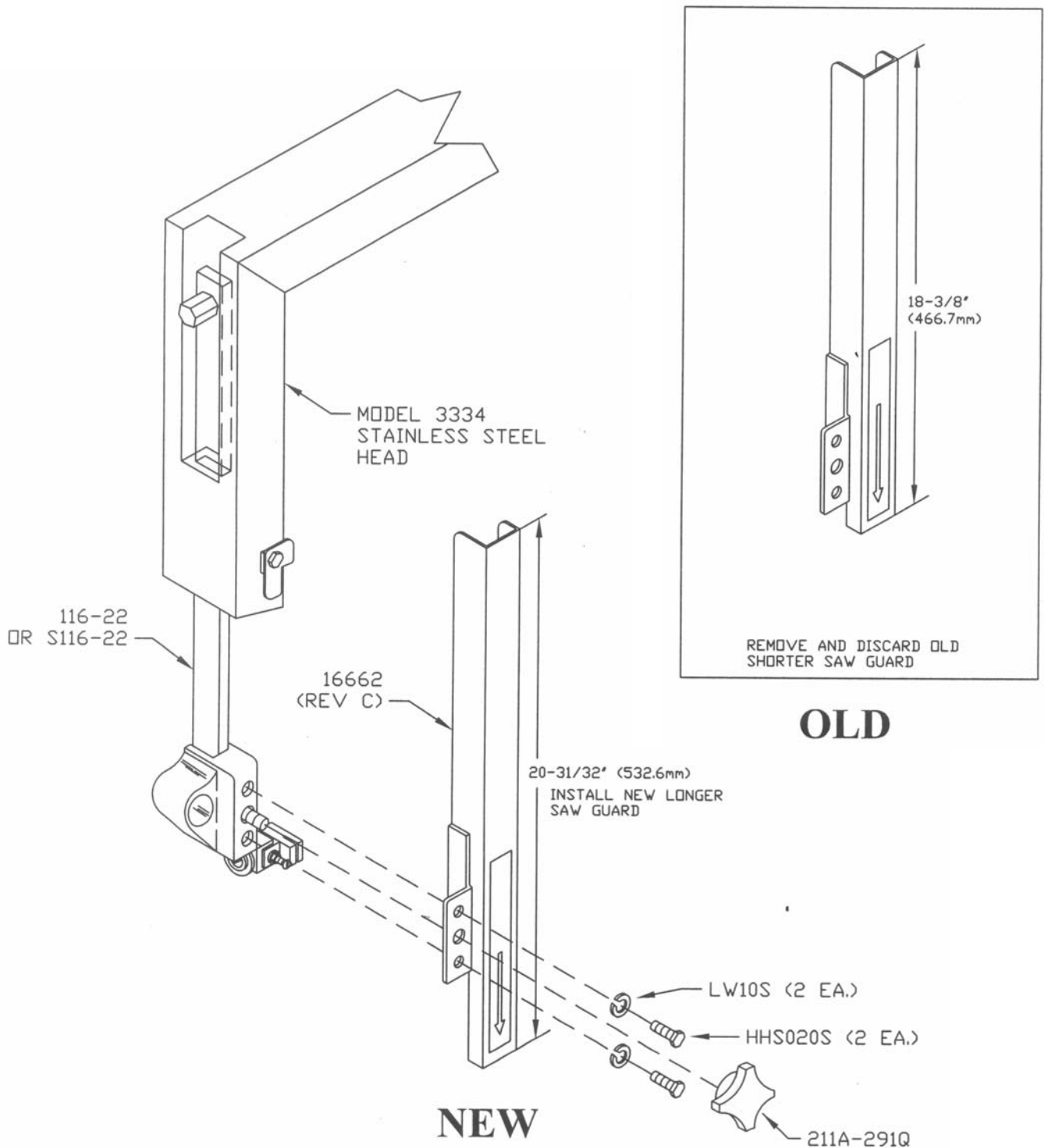

A16547-2
LOWER BEARING HOUSING ASSEMBLY,
CENTERING TYPE, WITHOUT WHEEL

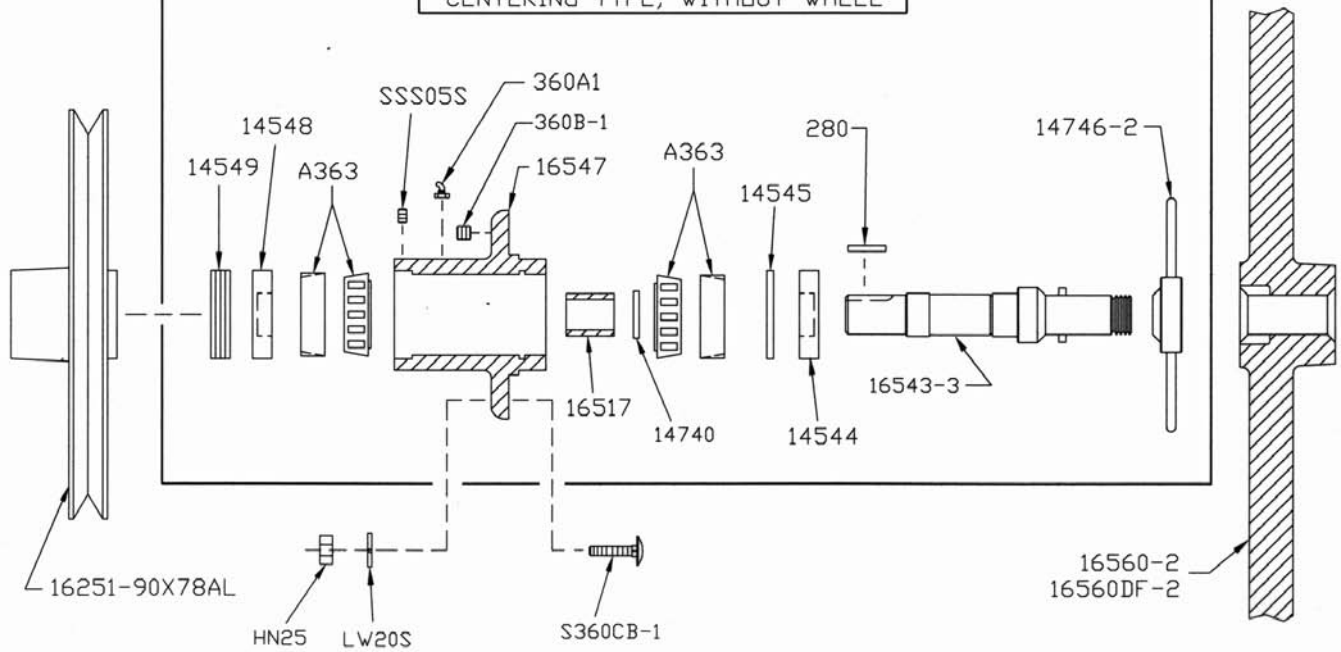

Item No.	Description
A16547-2	Lower bearing housing assembly without wheel
A363	Lower bearing cup/cone assembly
HN25	Hex nut $\frac{3}{8}$ -16, carbon-plated
LW25S	Lock washer, $\frac{3}{8}$ heavy
S360CB-1	Carriage bolt, $\frac{3}{8}$ -16 \times 1 $\frac{1}{4}$
SSS05S	Set screw, 10-24 \times $\frac{3}{8}$
12251AL- $\frac{7}{8}$ DBL	Pulley, 9 \times $\frac{7}{8}$ double V
14544	Grease seal
14545	Retaining ring, internal
14548	Grease seal
14549	Bearing adj. cap

Item No.	Description
14740	Retaining ring – external
14746-2	T-handle lock, removable lower wheel
16251-11 \times 78AL	Pulley, 11.4 \times $\frac{7}{8}$ AL
16251-90X78AL	Pulley, 9 \times $\frac{7}{8}$, al.
16517	Inner race spacer
16543-3	Lower shaft, remov. wheel
16547	Lower bearing housing
16560-2	Lower wheel, 16", 6 spoke removable
16560DF-2	Lower wheel, 16", 6 spoke removable – double flange
280	Lower shaft motor key
360A1	Grease fitting – angled
360B-1	Set screw, $\frac{1}{2}$ -13 SS

– OPERATOR'S NOTES –

REMOVAL and INSTALLATION **for Self-Centering Lower Removable Wheels** **(Model 3334 and 3334FH)**

ALWAYS Turn Off, Unplug Machine From Power Source and Perform Lockout/Tagout Procedure to the Machine **BEFORE** Cleaning or Servicing.

Follow disassembly procedures in the Cleaning Section of the Operating and Service Manual.

Removal of the T-Handle and Lower Wheel will be the last 2 parts removed in the number sequence.

REMOVAL

Loosen Item No. 14746-2, T-Handle Lock and Remove from Lower Shaft.



Using both hands @ 3 and 9 o'clock Positions, Pull wheel towards you with a even smooth motion.



INSTALLATION

There is a anti-rotation pin located on the lower shaft, there is a anti-rotation groove located on the back side of the lower wheel.

Align and engage the groove of the lower wheel and the anti-rotation pin as the wheel is being installed.

Install T-Handle Lock onto Lower Shaft, Hand Tighten **SECURELY**



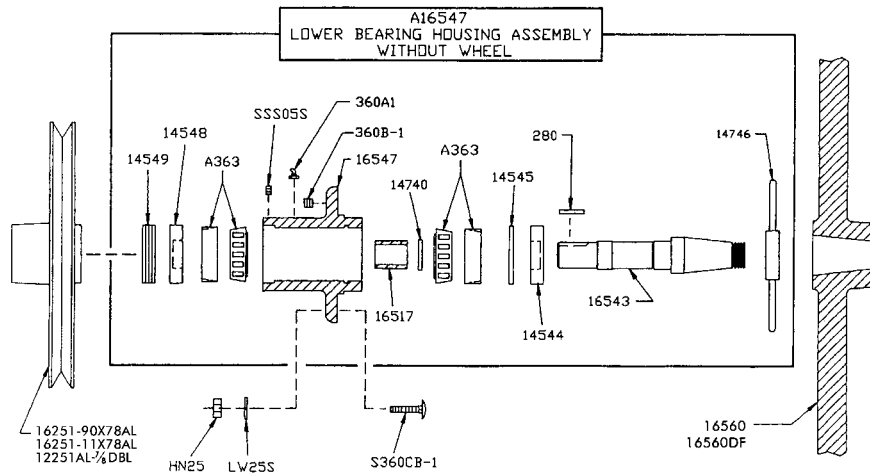

Item No.	Description	Item No.	Description
A16547	Lower bearing housing assembly without wheel	14746	T-handle lock, removable lower wheel
A363	Lower bearing cup/cone assembly	16251-11 x 78AL	Pulley, 11.4 x 7/8 alum.
HN25	Hex nut 7/8-16, carbon-plated	16251-90 x 78AL	Pulley, 9 x 7/8, al.
LW25S	Lock washer, 3/8 heavy	16517	Inner race spacer
S360CB-1	Carriage bolt, 3/8-16 x 1 1/4	16543	Lower shaft, remov. wheel
SSS05S	Set screw, 10-24 x 3/8	16547	Lower bearing housing
12251AL-7/8DBL	Pulley, 9 x 7/8 double-V	16560	Lower wheel, 16", 6 spoke removable
14544	Grease seal	16560DF	Lower wheel, 16", 6 spoke removable – double flange
14545	Retaining ring, internal	280	Lower shaft motor key
14548	Grease seal	360A1	Grease fitting – angled
14549	Lower bearing housing cap	360B-1	Set screw, 1/2-13 SS
14740	Retaining ring – external		

Item No. 16543 – Lower Shaft for Removable Wheel

The Model 3334 Lower Removable Wheel has been revised to include a keyway in the bore. Also an anti-rotation pin is now pressed into the lower shaft to prevent any inadvertent "spinning" of the wheel on the shaft.

NOTE – If the saw in which a new shaft is to be installed has a groove (keyway) in the bore of the lower wheel, press the taper pin (provided "loose") into the hole in the side of the shaft (see sketch).

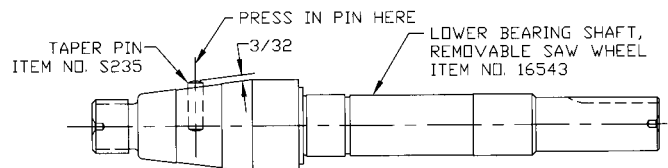

If there is no groove (keyway) in the bore of the lower wheel, discard the taper pin and use the shaft without the pin.

LOWER REMOVABLE WHEEL INSTALLATION AND REMOVAL INSTRUCTIONS FOR MODEL 1433 AND MODEL 3334SS

ALWAYS Turn Off, Unplug From Power Source and Perform Lockout/Tagout Procedure to the Machine **BEFORE** Cleaning or Servicing.

Follow disassembly procedures in the Cleaning Section of the Operating and Service Manual.

Removal of the Lower Wheel will be last procedure.

REMOVAL

Loosen the Item No. 14746 T-Handle Lock, **DO NOT REMOVE COMPLETELY FROM SHAFT.**

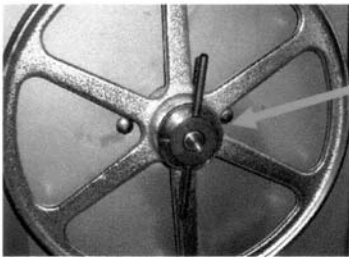

14746
T-Handle Lock



**T-HANDLE
LOOSENED**

Using thumbs for leverage, pull wheel toward you with an even-smooth motion. Wheel is mounted in slip fit fashion on a tapered shaft. When the wheel is loose, complete removing T-handle lock and wheel.



14746
T-Handle Lock



INSTALLATION

There is an alignment pin on the lower shaft. And a mating alignment groove in the hub of the lower wheel. Align the two as the wheel is being installed on the tapered shaft.

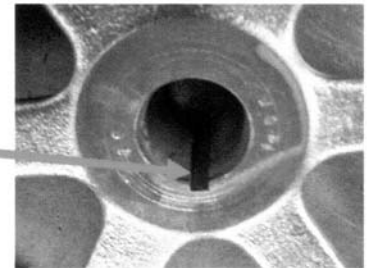

**NOTE:
TO ENSURE PROPER SAW WHEEL
ALIGNMENT, WHEEL MUST BE
REINSTALLED ON SAME
MACHINE FROM WHICH IT WAS
REMOVED.**

Replace the T-Handle Lock
HAND TIGHTEN ONLY
Reassemble the machine.



– OPERATOR’S NOTES –

A609AAW-16 SWITCH ASSEMBLY

Item No.	Description
A16226A	Green/red switch button assembly w/springs
A609AAW-16	Switch assembly, 1 & 3 ph less heater coils
H462	Guard for switch toggle
H462A	Guard assembly for switch toggle
H462-1	Trim ferrule, SS
HHS010S	Hex head screw, 10-32 x 3/8 SS
HHS070S	Hex head screw, 3/8-16 x 1 SS
HN10S	Hex nut, 10-32 SS
HN20S	Hex nut 3/16-18 SS heavy
LW15S	Lock washer 3/16 SS regular
LW25S	Lock washer, 3/8 SS
16296-2	Switch bracket SS
150	Conduit, 1/2"
224	Conduit connector, 180°
226-28	Washer SS, 1 1/2 x 27/32
241BL	Wire, black, 12GA., CSA & UL
241WH	Wire, white, 12GA., CSA & UL
259	Anti-short bushing - 1/2"
340	Star lock washer
609AAW	Manual switch, size 0, 1 & 3 ph

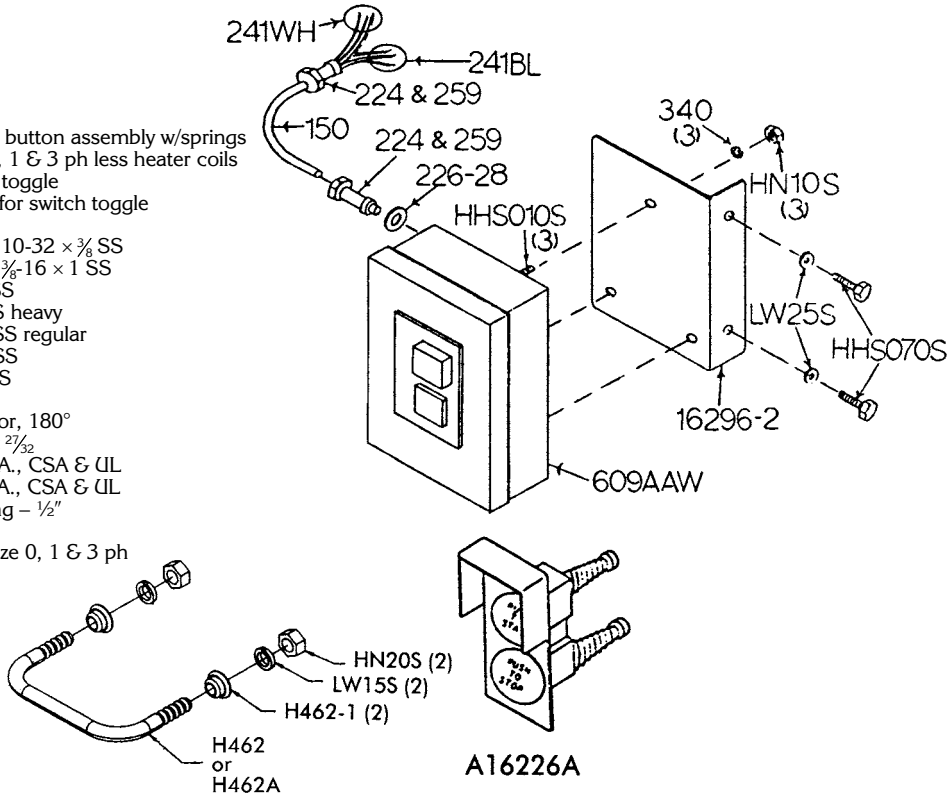

609AAW 3 - PHASE

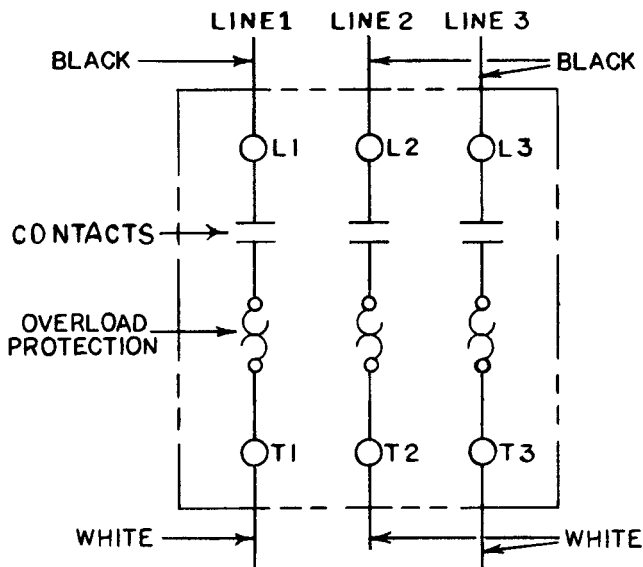

- Wire Diagram for Baldor Motor - - Spec. No. 35M388S508 -

230V/1 Phase/50Hz
Used with 609 AAW Starter, A-B

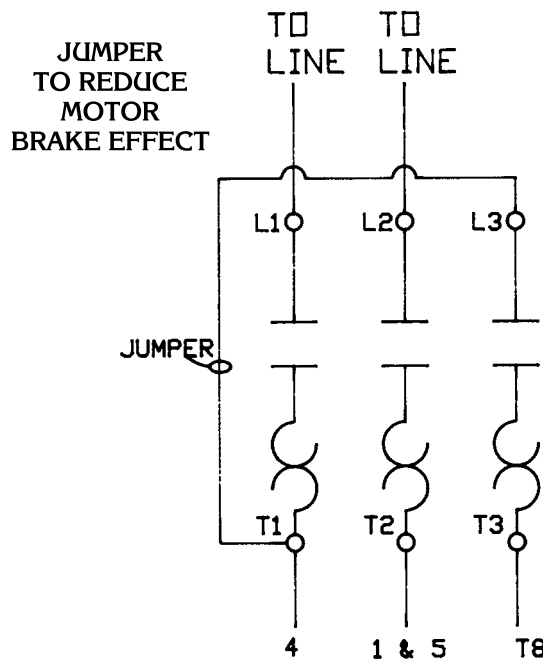

MOTOR LEADS
SWITCH 5 & 8 FOR CORRECT ROTATION

WATERTIGHT MAGNETIC SWITCH ASSEMBLIES (AEG) INCLUDES MOUNTING BRACKET AND WIRES

Item No.	Description	Item No.	Description
A22616EE-514	BAEG/MS-PB/05-C8 2HP 208-220-50/60-3	A22616EE-530	BAEG/MS-PB/05-F3.2 2HP 550/575-3
A22616EE-516	BAEG/MS-PB/05-E4.7 2HP 440/460-3	A22616EE-534	BAEG/MS-PB/05-E6.3 3HP 440/460-60-3
A22616EE-518	BAEG/MS-PB/05-D4.7 1.5HP-2HP 380/415-50-3	A22616EE-536	BAEG/MS-PB/05-D8 3HP 380-60-3
A22616EE-522	BAEG/MS-PB/05-C14 3HP 220-230-50/60-3	A22616EE-538	BAEG/MS-PB/05-F4.7 3HP 550-60-3
A22616EE-5221	BAEG/MS-PB/05-CS14 1.5HP 220/230-50/60-1	A22616EE-540	BAEG/MS-PB/C18 5HP 220-60-3
A22616EE-5241	BAEG/MS-PB/A26 1.5HP-2HP 104/115/60-1	A22616EE-544	BAEG/MS-PB/05-E8 5HP 440/460-60-3
A22616EE-5261	BAEG/MS-PB/CS16 2HP 230-60-1	A22616EE-546	BAEG/MS-PB/05-D14 5HP 380/415-50-3
		A22616EE-548	BAEG/MS-PB/05-F8 5HP 550/575-60-3

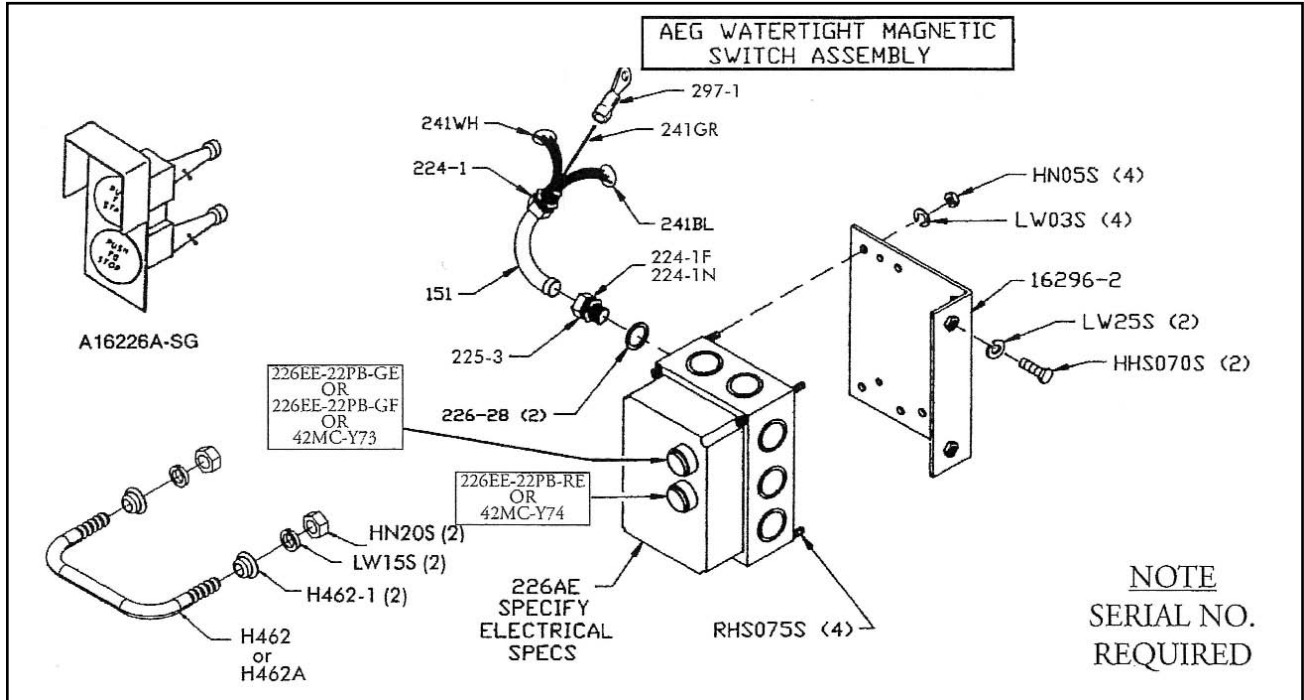

Item No.	Description	Item No.	Description
A16226A-SG	Green/red switch button assembly	226EE-EO	Contactors, LS05.10-EO 440-480V
H462	Guard for switch toggle	226EE-FO	Contactors, LS05.10-FO, 550V
H462A	Guard assembly for switch toggle	226EE-506	BAEG/MS-PBF/05-C6.3 1HP 220-50/60-3
H462-1	Trim ferrule S.S.	226EE-514	BAEG/MS-PB/05-C8 2HP 220-50/60-3
HHS070S	Hex head screw, 3/8-16 x 1 SS	226EE-516	BAEG/MS-PB/05-E4.7 2HP 440-60-3
HN05S	Hex nut, 8-32 SS	226EE-516F	BAEG/MS-PBF/05-E4.7 1-1/2-2HP 440-60-3
HN20S	Hex nut 5/16-18 SS	226EE-518	BAEG/MS-PB/05-D4.7 2HP 380-50-3
LW03S	Lock washer, #8 SS	226EE-5201	BAEG/MS-PBF/A26 1-1/2 & 2HP 60-1
LW15S	Lock washer 5/16, SS	226EE-522	BAEG/MS-PB/05-C14 3HP 230-50/60-3
LW25S	lock washer, 3/8 heavy SS	226EE-5241	BAEG-MS-PB/A26 2HP 120-60-1
RHS075S	Round head screw, 8-32 x 3/4 SS	226EE-5261	BAEG-MS-PB/CS16 2HP 230-60-1
16296-2	Switch bracket SS	226EE-530	BAEG-MS-PB/05-F3.2 2HP 550-60-3
151	Watertight conduit	226EE-534	BAEG/MS-PB/05-E6.3 3HP 440-60-3
224-1	Conduit connector, WT, 180°	226EE-536	BAEG/MS-PB/05-D8 3HP 380-50-3
224-1F	Conduit ferrule for watertight connector	226EE-538	BAEG/PC-PB/05-F4.7 3HP 550-60-3
224-1N	Conduit nut for watertight connector	226EE-540	BAEG/MS-PB/C18 5HP 220-60-3
226EE-ENCL-PB30	Enclosure w/pushbutton 30mm holes	226EE-544	BAEG/MS-PB/05-E8 5HP 440-60-3
226EE-OL01.9G	Overload B18K-G, 1.3-1.9A	226EE-546	BAEG/MS-PB/D14 5HP 380-415-50-3
226EE-OL41	Overload B18K-I, 2.5-4A	226EE-548	BAEG/MS-PB/05-F8 5HP 550-60-3
H281EE-51	Overload B18K-K, 4-6.3A	226-28	Washer, 1-1/2 x 27/32 SS
226EE-OL08.5L	Overload B18K-L, 5.5-8.5A	241BL	Wire, black 12 GA., CSA & UL
226EE-OL12M	Overload B18K-M, 8-12A	241GR	Wire, green, 12 GA., CSA & UL
226EE-OL18O	Overload B18K-O, 14.5-18A	241WH	Wire, White, 12 GA., CSA & UL
226EE-OL26ON	Overload B18K-ON, 21-26A	297-1	Wire terminal eyelet for 12 GA wire
226EE-AO	Contactors, LS05.10-AO, 120V	42MC-Y73	Green start push button assembly
226EE-CO	Contactors, LS05.10-CO, 208-230V	42MC-Y74	Red Stop push button assembly
226EE-DO	Contactors, LS05.10-DO, 380-415V		

-115 VOLT WITH 6 LEADS-

SCHEMATIC USING 3-POLE AEG WATERTIGHT SWITCH WITH JUMPER TO ELIMINATE BREAKING EFFECT OF MOTOR AFTER STOP IS ENGAGED. 2HP & 3HP/60HZ/1PH BALDOR MOTOR WITH 6 MOTOR LEADS WIRED FOR 115 VOLTS

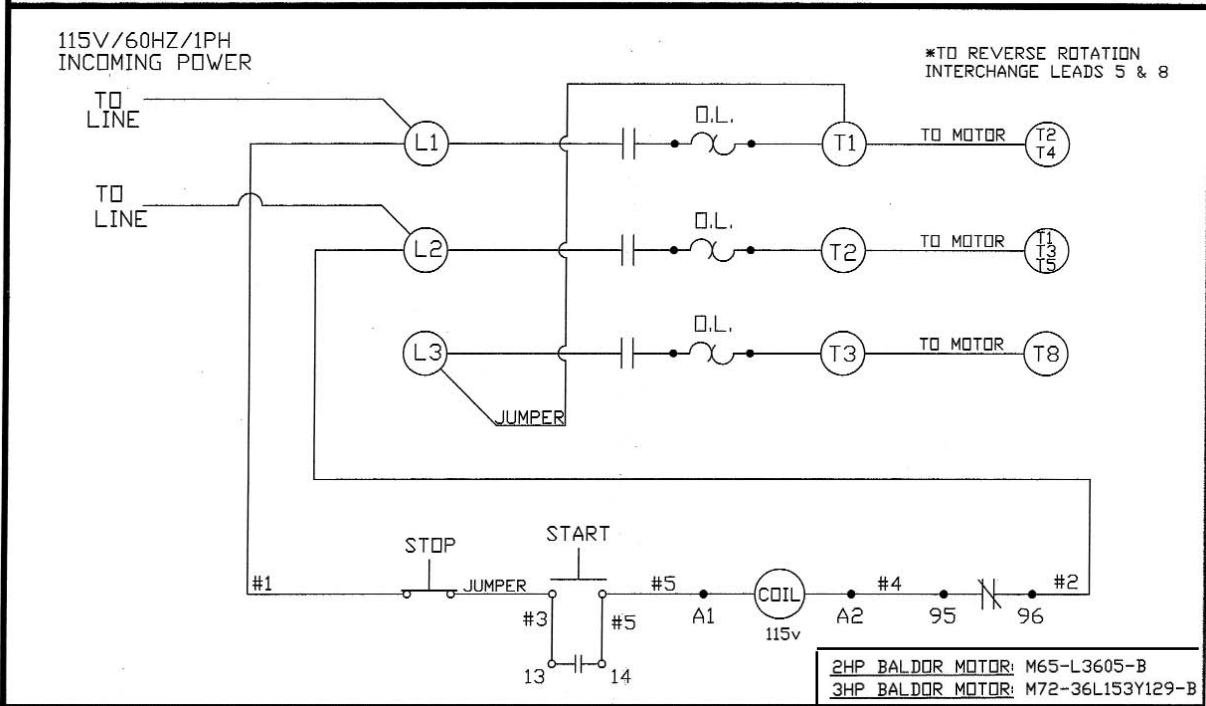

-115 VOLT WITH 6 LEADS-

SCHEMATIC USING 3-POLE AEG WATERTIGHT SWITCH WITH JUMPER TO ELIMINATE BREAKING EFFECT OF MOTOR AFTER STOP IS ENGAGED. 2HP/50HZ/1PH BALDOR MOTOR WITH 6 MOTOR LEADS, WIRED FOR 115 VOLTS

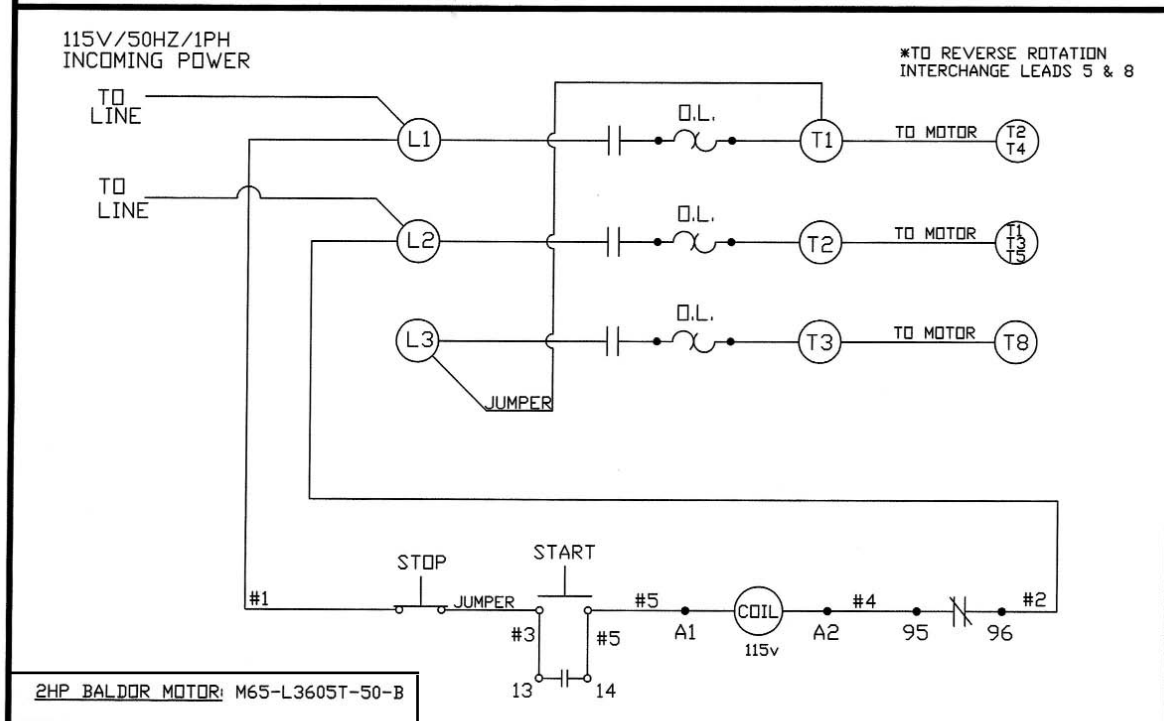

-115 VOLT WITH 7 LEADS-

SCHEMATIC USING 3-POLE AEG WATERTIGHT SWITCH WITH JUMPER TO ELIMINATE BREAKING EFFECT OF MOTOR AFTER STOP IS ENGAGED, 2HP/60HZ/1PH BALDOR MOTOR WITH 7 MOTOR LEADS, WIRED FOR 115 VOLTS

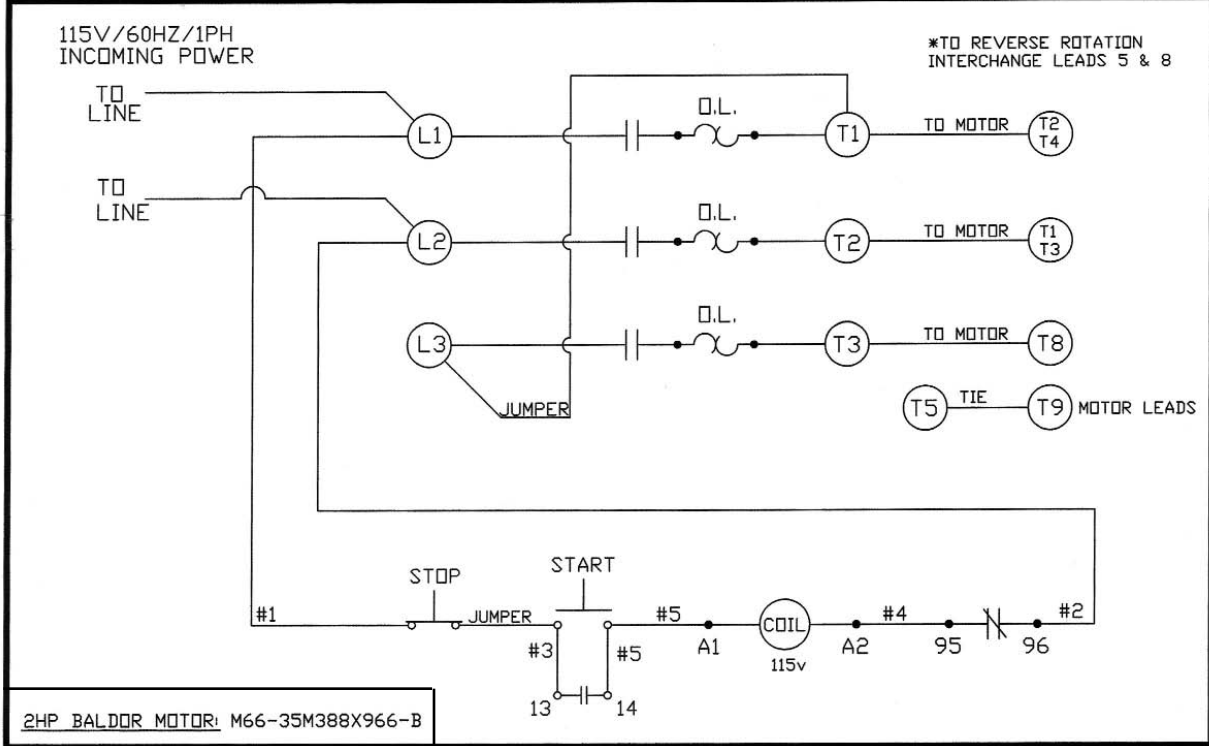

-230 VOLT WITH 6 LEADS-

SCHEMATIC USING 3-POLE AEG WATERTIGHT SWITCH WITH JUMPER TO ELIMINATE BREAKING EFFECT OF MOTOR AFTER STOP IS ENGAGED, 2HP & 3HP/60HZ/1PH BALDOR MOTOR WITH 6 MOTOR LEADS WIRED FOR 230 VOLTS

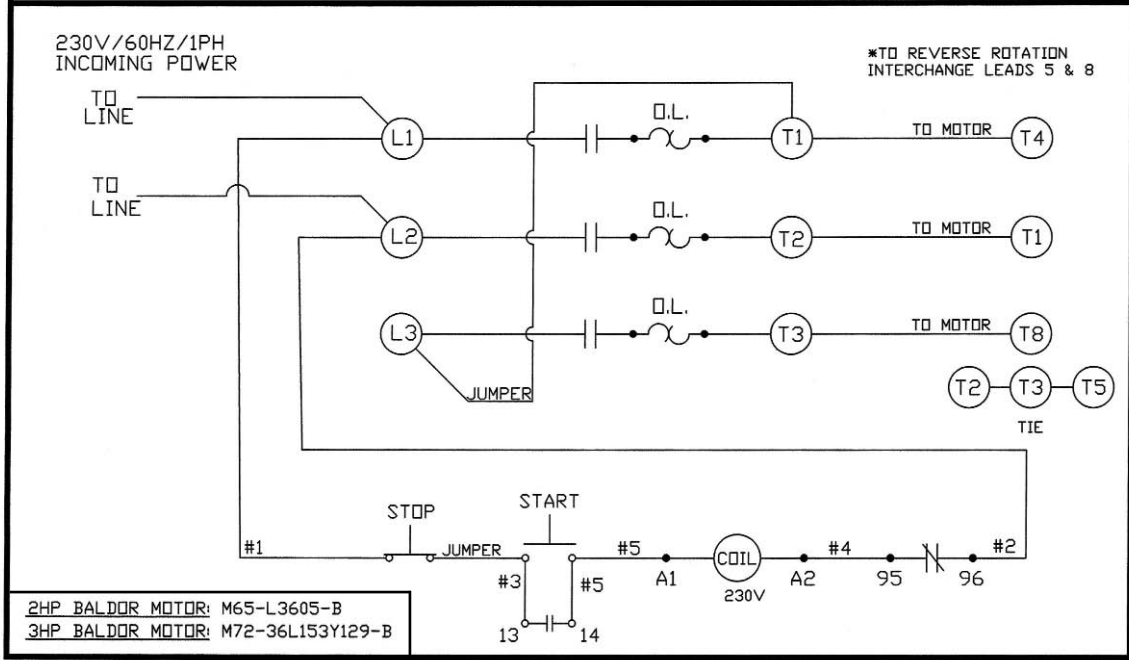

-230 VOLT WITH 6 LEADS-

SCHEMATIC USING 3-POLE AEG WATERTIGHT SWITCH WITH JUMPER
TO ELIMINATE BREAKING EFFECT OF MOTOR AFTER STOP IS ENGAGED,
2HP/50HZ/1PH BALDOR MOTOR WITH 6 MOTOR LEADS, WIRED FOR 230 VOLTS

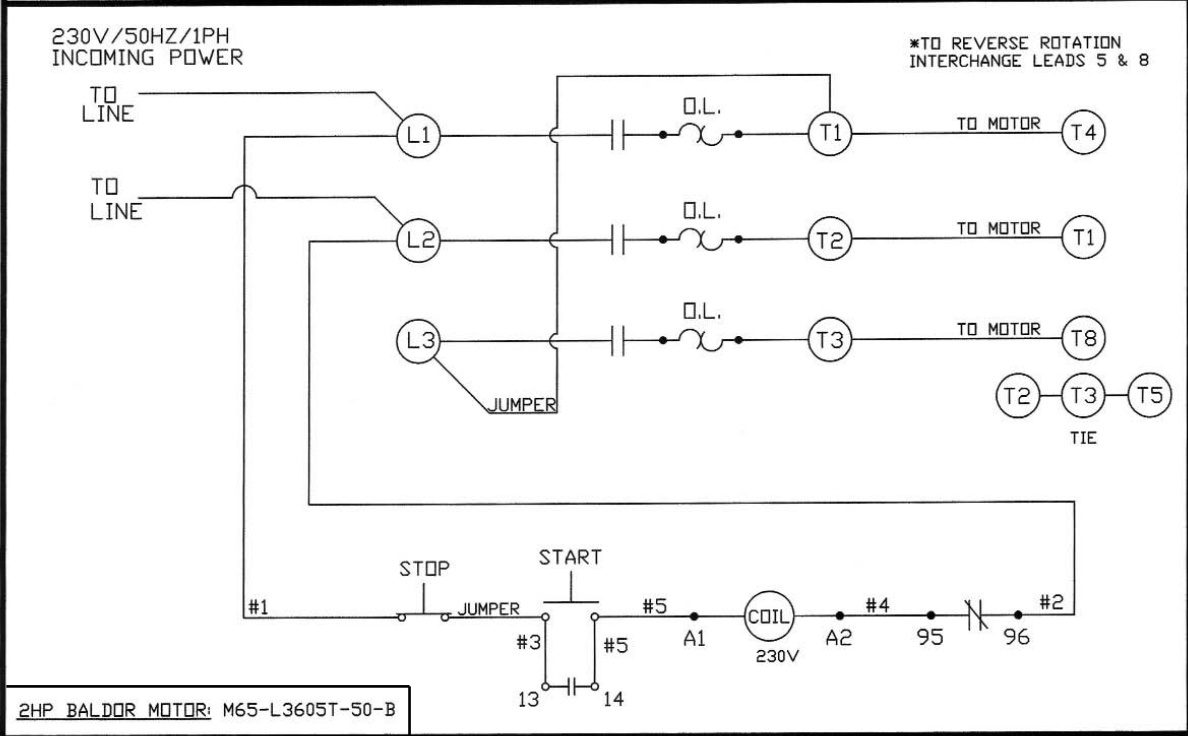

-230 VOLT WITH 7 LEADS-

SCHEMATIC USING 3-POLE AEG WATERTIGHT SWITCH WITH JUMPER
TO ELIMINATE BREAKING EFFECT OF MOTOR AFTER STOP IS ENGAGED,
2HP/60HZ/1PH BALDOR MOTOR WITH 7 MOTOR LEADS, WIRED FOR 230 VOLTS

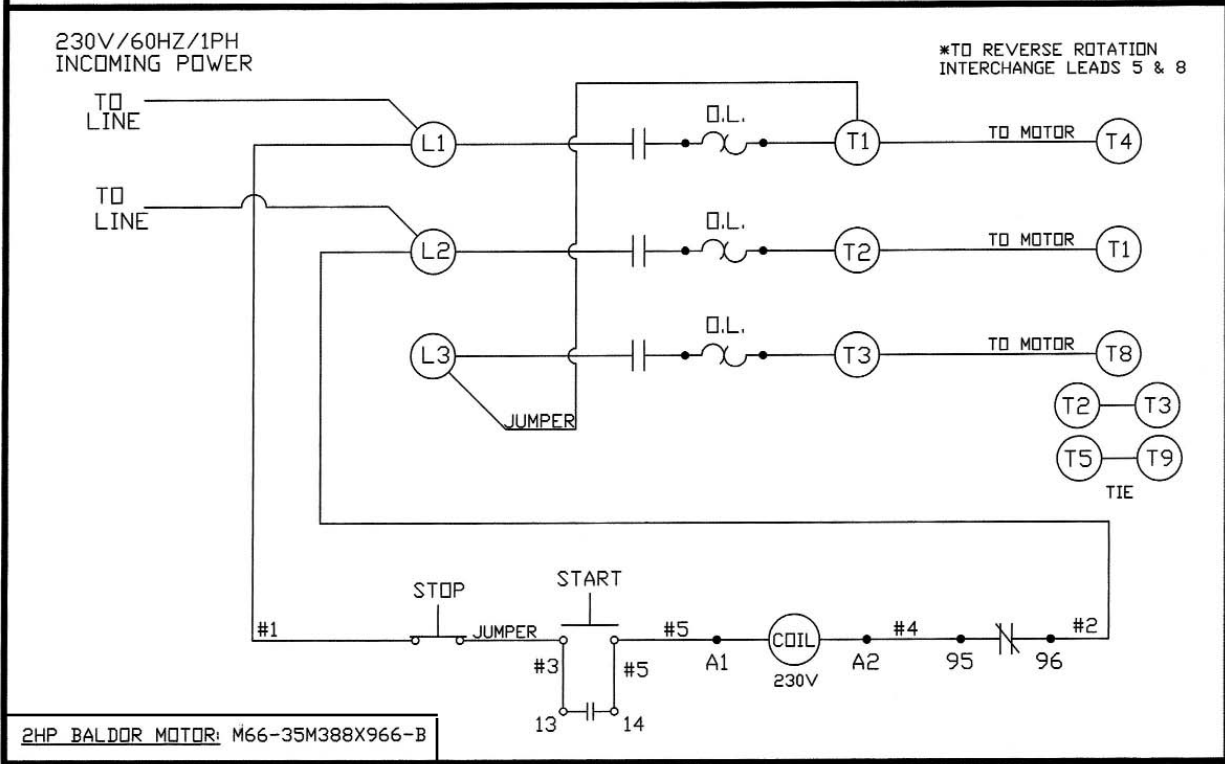

-208/230 VOLT WITH 9 LEADS-

SCHEMATIC USING 3-POLE AEG W.T. SWITCH
 2HP/50/60HZ/3PH WEG MOTOR WITH 9 MOTOR LEADS WIRED FOR 208/230 VOLTS

208/230V/50/60HZ/3PH
 INCOMING POWER

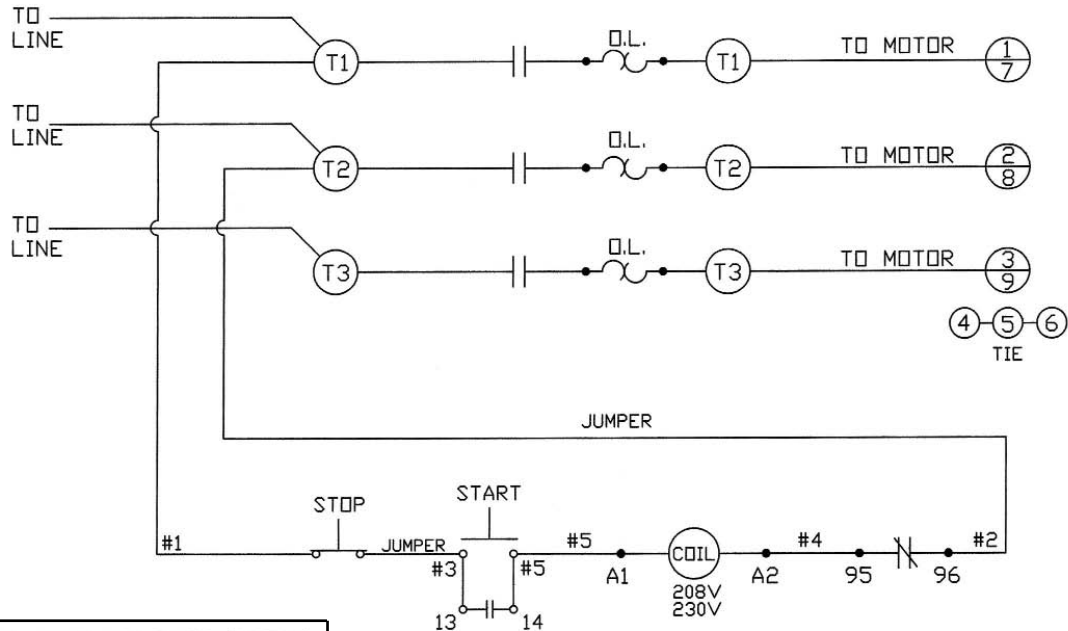

2HP WEG MOTOR: M68-218EP3E145T-W

-208/220/230 VOLT 3 PHASE WITH 9 LEADS-

SCHEMATIC USING 3-POLE STROMBERG OR AEG W.T. SWITCH
 2HP/60HZ/3PH BALDOR MOTOR WITH 9 MOTOR LEADS (OR)
 2HP & 3HP/50/60HZ/3PH US ELECTRIC/EMERSON MOTOR WITH 9 MOTOR LEADS
 WIRED FOR 208/220/230 VOLTS

208/220/230V/60HZ/3PH
 INCOMING POWER

2HP BALDOR MOTOR: M68-M3558T-B
 2HP US ELECTRIC/EMERSON MOTOR: M55-G54313-U
 3HP US ELECTRIC/EMERSON MOTOR: M701-G57011-U

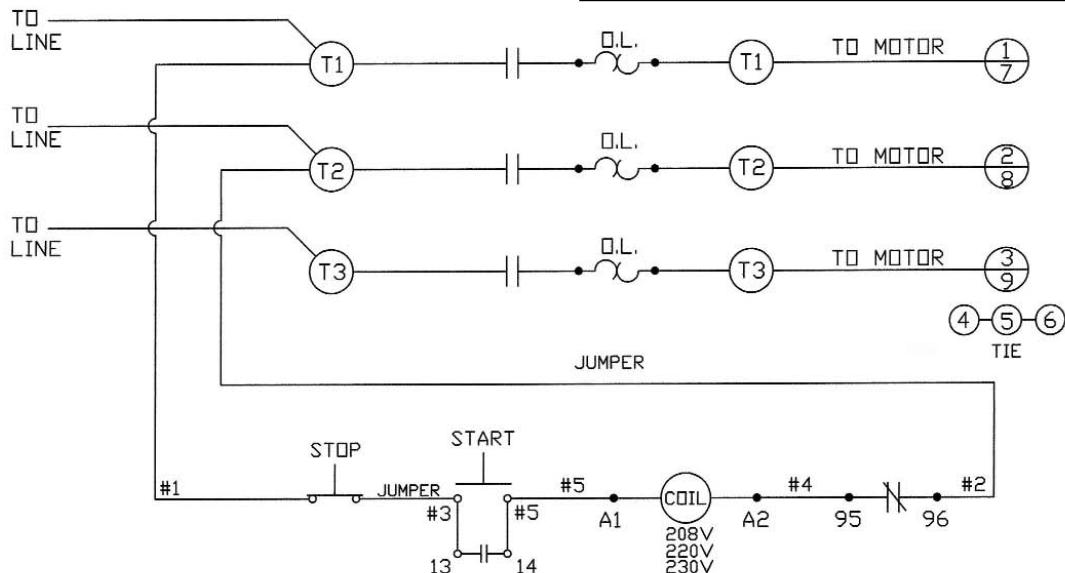

-208/220/230 VOLT 3 PHASE WITH 9 LEADS-
 SCHEMATIC USING 3-POLE AEG W.T. SWITCH
 3HP/60HZ/3PH US ELECTRIC/EMERSON MOTOR WITH 9 MOTOR LEADS
 WIRED FOR 208/220/230 VOLTS

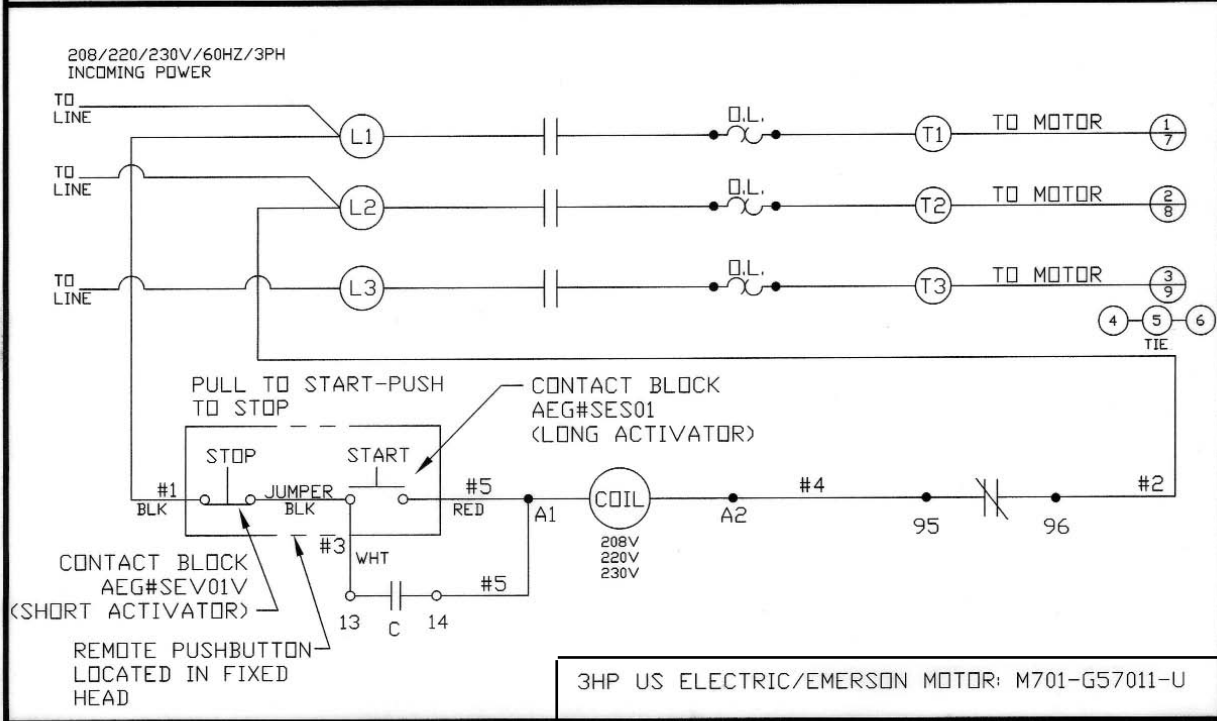

-220 VOLT 3 PHASE WITH 12 LEADS-
 SCHEMATIC USING 3-POLE STROMBERG OR AEG W.T. SWITCH
 2HP/50HZ/3PH BALDOR MOTOR WITH 12 MOTOR LEADS WIRED FOR 220 VOLTS

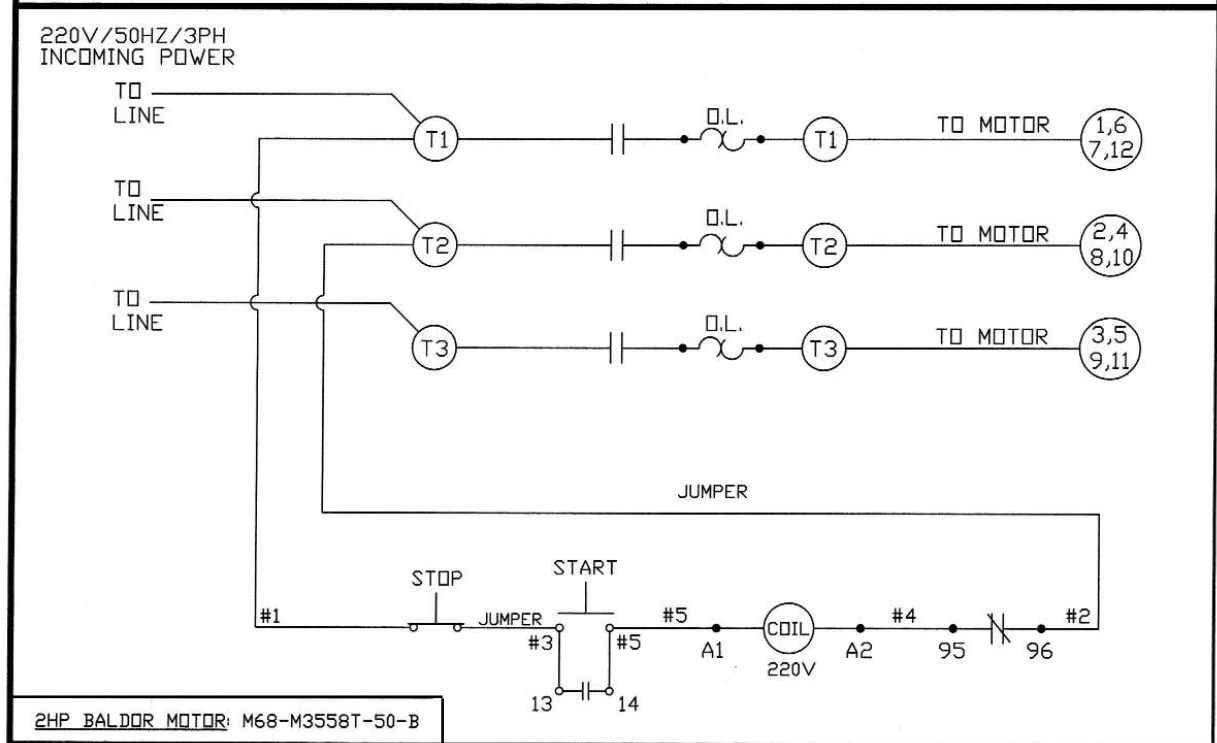

-380/460 VOLT WITH 9 LEADS

SCHEMATIC USING 3-POLE AEG W.T. SWITCH
 2HP/50/60HZ/3PH WEG MOTOR WITH 9 MOTOR LEADS WIRED FOR 380/460 VOLTS

380/460V/50/60HZ/3PH
 INCOMING POWER

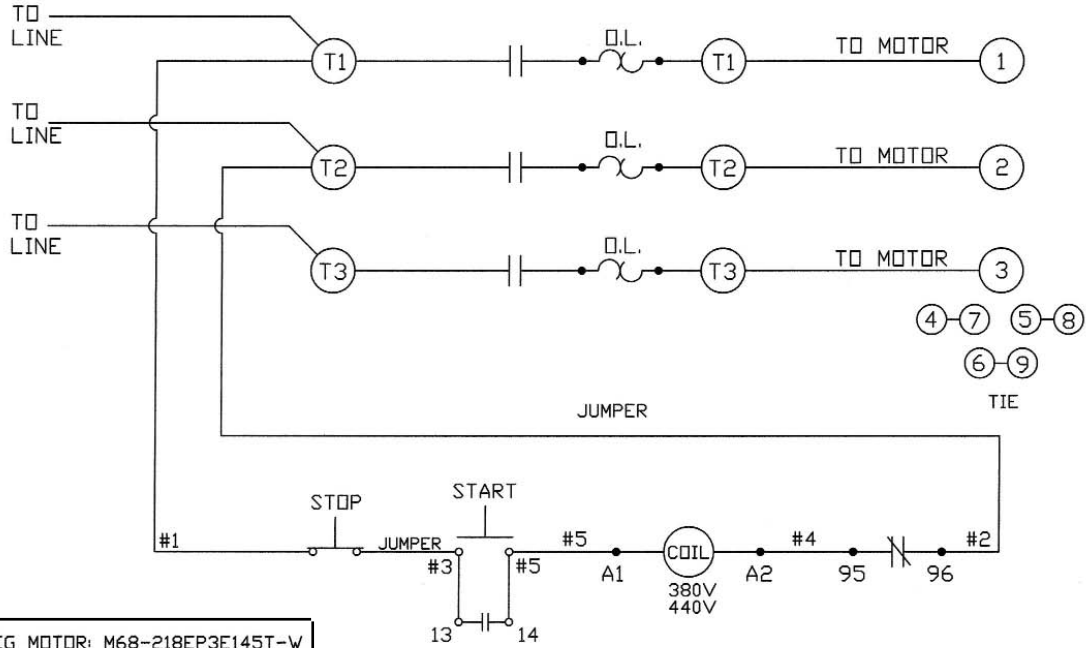

2HP WEG MOTOR: M68-218EP3E145T-W

-380 VOLT, 3 PHASE WITH 12 LEADS-

SCHEMATIC USING 3-POLE STROMBERG OR AEG W.T. SWITCH
 2HP/50HZ/3PH BALDOR MOTOR WITH 12 MOTOR LEADS WIRED FOR 380 VOLTS

380V/50HZ/3PH
 INCOMING POWER

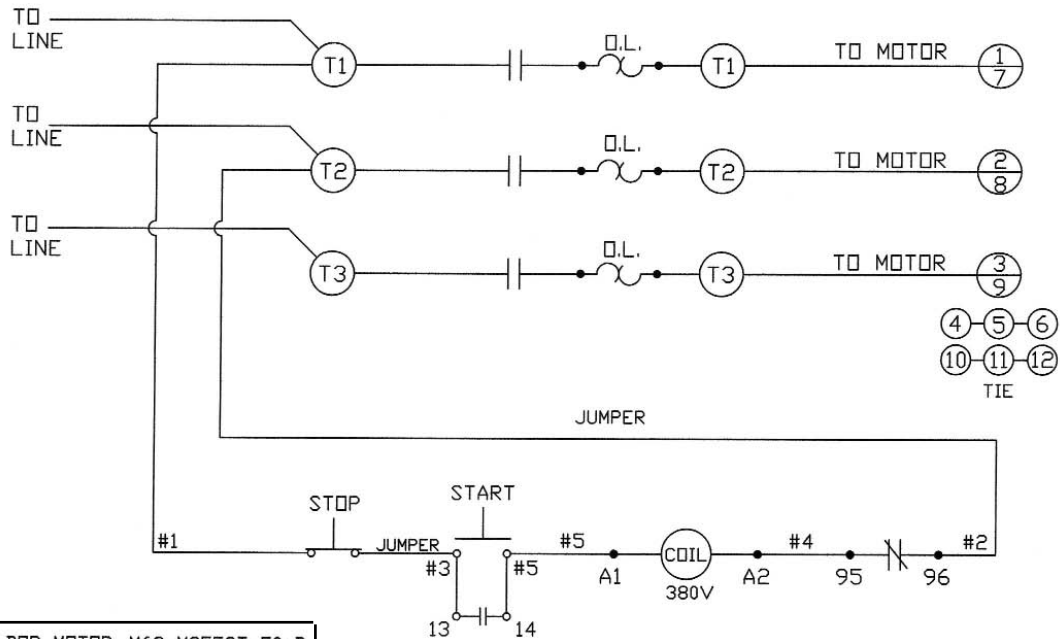

2HP BALDOR MOTOR: M68-M3558T-50-B

-440/460 VOLT 3 PHASE WITH 9 LEADS-

SCHEMATIC USING 3-POLE STROMBERG OR AEG W.T. SWITCH
 2HP/60HZ/3PH BALDOR MOTOR WITH 9 MOTOR LEADS (OR)
 2HP & 3HP/50/60HZ/3PH US ELECTRIC/EMERSON MOTOR WITH 9 MOTOR LEADS
 WIRED FOR 440/460 VOLTS

440/460V/50/60HZ/3PH
 INCOMING POWER

2HP BALDOR MOTOR: M68-M3558T-B
 2HP US ELECTRIC/EMERSON MOTOR: M55-G54313-U
 3HP US ELECTRIC/EMERSON MOTOR: M701-G57011-U

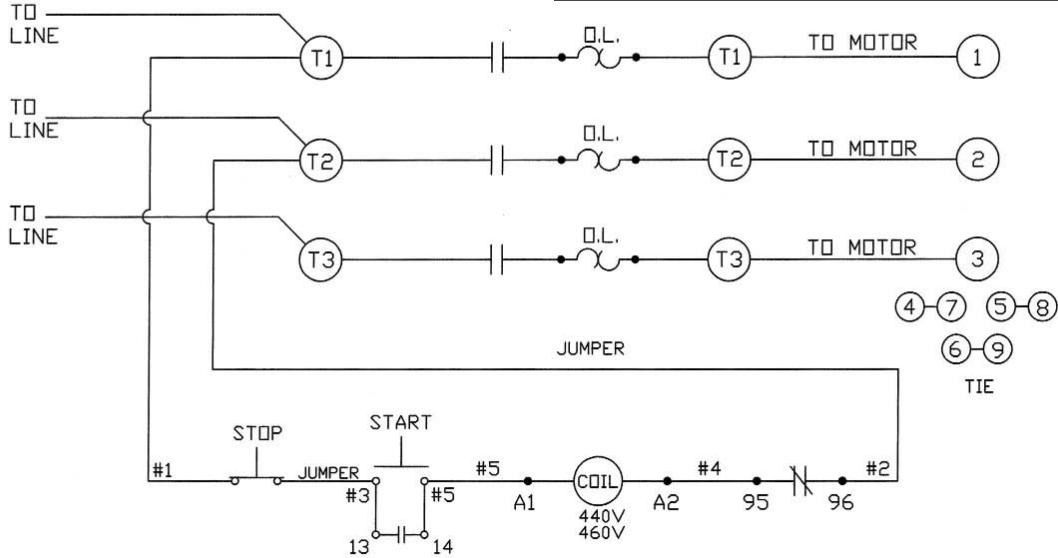

-440 VOLT, 3 PHASE WITH 12 LEADS-

SCHEMATIC USING 3-POLE STROMBERG OR AEG W.T. SWITCH
 2HP/50HZ/3PH BALDOR MOTOR WITH 12 MOTOR LEADS WIRED FOR 440 VOLTS

440V/50HZ/3PH
 INCOMING POWER

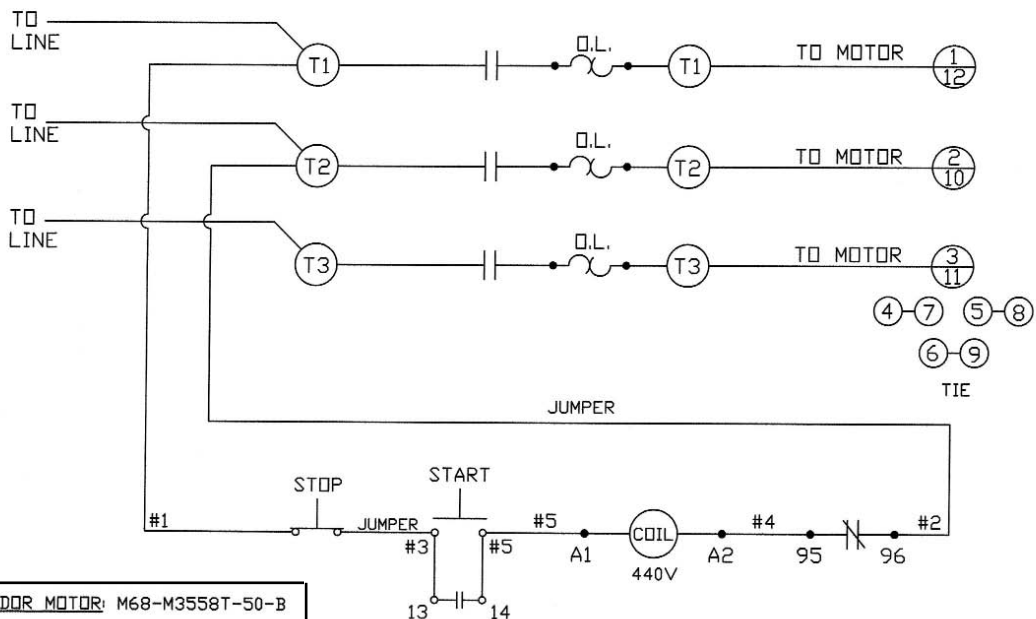

2HP BALDOR MOTOR: M68-M3558T-50-B

– OPERATOR’S NOTES –

CLEANING



SHARP MOVING BAND TYPE SAW BLADE TO AVOID SERIOUS PERSONAL INJURY

ALWAYS Turn Off, Unplug From Power Source and Perform Lockout/Tagout Procedure to This Machine **BEFORE** Cleaning or Servicing.

ONLY Use Recommended Cleaning Equipment, Materials and Procedures.

NEVER Spray Water or Other Liquid Substances Directly at Motor, Power Switch or any Other Electrical Components.

ALWAYS Thoroughly Clean Equipment at Least Daily.

CLEANING THE BIRO POWER CUTTER:

Disconnect electrical power to the machine before cleaning. Parts to be removed have been made accessible and can be removed without tools. Notice in the drawing below that all parts are numbered. Each part should be removed for cleaning in the numbered sequence shown. To ensure cleaner cuts, keep the parts on the cleaning system in good condition. Parts on the cleaning system which should be checked weekly, and changed as required are as follows: Wheel Cleaners (Part No. 179), Saw Cleaners (Part No. 131), Saw Guide in Stationary Bar (Part No. 119A), Upper Saw Guide (Part No. 602B), Lower Blade Back-Up Guide (Part No. 605) and Nylon Filler (Part No. 177).

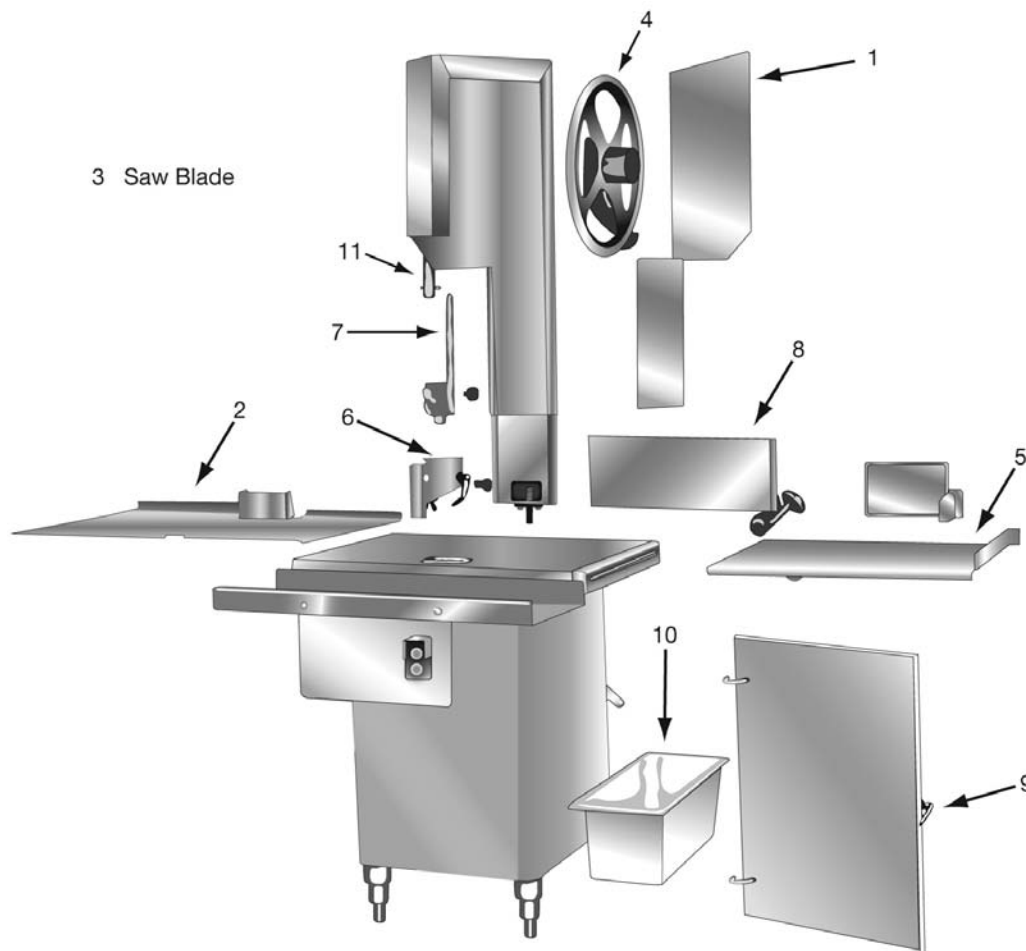

MODEL 3334FH & 3334-4003FH
PART NUMBERS AND DESCRIPTIONS
MODEL & SERIAL NO. REQUIRED WHEN ORDERING PARTS

Item No.	Description	Item No.	Description
AN15S	Acorn nut, 1/4-20, SS	S16290	Cleaning unit, SS
AN20S	Acorn nut, 3/8-16, SS	S16335XE	Upper wheel hinge plate, SS
AN21S	Acorn nut, high crown SS 3/8-16	S163F	Platter spacer weld button, SS
CB98S	Carriage bolt, 3/8-16 x 2 3/4, SS	S181155AEZ	Meat carriage angle, EZ flow (order S18155EZ-1)
FW05S	Flat washer, 1/4, SS	S18155EZ	Carriage top only (order S18155EZ-1)
FW07S	Flat washer 3/8 SAW 7/8 x 1 1/2 x 1/16, SS	S18155EZ-1	Carriage top w/weld studs
FW08S	Flat washer, 3/8 ID x 1" OD, SS	S200B1	Stop stud, guide bar & carriage stop
FW10S	Flat washer, 5/16, SS	S229	Wheel cleaner arm spring, SS
FW15S	Flat washer, 1/2, SS	S235	Taper pin, 4 x 3/4, SS
HHS003S	Hex head screw, 8-32 x 1/4, SS	S239-B40	Base foot, welded, SS
HHS005S	Hex head screw, 8-32 x 1/2, SS	S239-B41	Adjustable leg bolt, SS
HHS010S	Hex head screw, 10-32 x 3/8, SS	S244	Wheel cleaner arm stud
HHS015S	Hex head screw, 10-32 x 1/2, SS	S253	Upper wheel aligning screw, SS
HHS020S	Hex head screw, 1/4-20 x 3/8, SS	S262	Meat gauge release handle, SS
HHS025S	Hex head screw, 1/4-20 x 1/2, SS	S265	Meat gauge release spring, SS
HHS035S	Hex head screw, 1/4-20 x 5/8, SS	S268	Stationary bar headless screw, SS
HHS040S	Hex head screw, 1/4-20 x 3/4, SS	S270	Meat gauge release pin w/hole, SS
HHS048S	Hex head screw, 1/4-20 x 1 1/4, SS	S295	Wheel cleaner arm, stainless
HHS0481S	Hex head screw, 1/4-20 x 1 1/2, SS	S325	Wheel cleaner arm washer, SS
HHS049NL	Hex head screw, 5/16-18 x 1/2, nylon	S360CB-1	Carriage bolt 3/8-16 x 1 1/4 SS
HHS050S	Hex head screw, 7/16-18 x 3/8, SS	S415D	Stainless stationary bar
HHS055S	Hex head screw, 5/16-18 x 3/4, SS	S416	Platter locator weld pin, SS
HHS060S	Hex head screw, 5/16-18 x 1, SS	S71-3	Upper wheel hinge bracket, fixed head
HHS067S	Hex head screw, 3/8-16 x 3/4, SS	VTS7181	BIRO logo oval decal - NSS
HHS070S	Hex head screw, 3/8-16 x 1, SS	112-212	Waved washer, 2 1/4 ID, 5/8 OD
HHS075S	Hex head screw, 7/8-16 x 1 1/4, SS	116-22	Saw guide bar 22 inch
HHS083S	Hex head cap screw, 3/8-16 x 1 1/4, SS	116-22-COS	Saw guide bar, SS, special
HN05S	Hex nut, 8-32, SS	119A	Saw guide
HN10S	Hex nut, 10-32, SS	119FSC	Saw guide, fish
HN15S	Hex nut, 1/4-20, SS	12251AL	Upper V-belt pulley 9.0 x 1, aluminum
HN20S	Hex nut, 3/8-18, SS	12251AL-DBL	Upper pulley, double-V, 9 x 1
HN25	Hex nut, 3/8-16, plated	12251AL-7/8DBL	Pulley, 9 x 7/8, aluminum, double V
HN25S	Hex nut, 3/8-16, SS	130	Saw cleaner bracket, rear
HN30S	Hex nut, 3/8-16, light jam, SS	131	Saw cleaner
HN35S	Hex nut, 3/8-16, heavy jam, SS	14GP	Hinge pin, 1 1/2"
HNNL15S	Hex nut, 1/4-20 SS heavy nylok	14GP-1	Hinge pin, 1 1/4"
HNNL25S	Hex nut, 3/8-16 SS nylok	14R	Hinge receiver
LH663	Left hand saw guard	14TH	Hinge pin holder
LW05S	Lock washer, #10, SS	14TP	Head door hinge pin, long
LW10S	Lock washer, 1/4, SS	14TP-1	Head door hinge pin, short
LW15S	Lock washer, 3/8, SS	14544	Grease seal, 1.5 I.D.
LW20S	Lock washer, 3/8, regular, SS	14545	Ret. ring, internal
LW25S	Lock washer, heavy 3/8, SS	14548	Grease seal
M55-G54313-U	Motor, 2HP 208/220/440-50/60-3, open	14549	Lower bearing housing cap
M65-L3605-B	Motor, 2HP, 115/230-60-1 TE	14554	Compression spring
M68-M3558T-B	Motor 2HP 208/220/230/440/460-60-3 TE	14668	Motor pulley, double-V 6 x 1 1/8
M701-G57011-U	Motor, 3HP, 220/440-50/60-3, TE	14669	Pulley, double-V, 5 x 1 1/8
M66-35M388X966-B	Motor, 2HP, 115/230-60-1 Open	14730	Belt, double-V, 44" 2/7M1120
M72-36L153Y129-B	Motor, 3HP, 115/208/230-60-1, TE	14740	Retaining ring, external 25mm
RHS09S	Round head screw, 10-32 x 3/8, SS	14746	T-handle lock, lower removable wheel
RHS075S	Round head screw, 8-32 x 3/4, SS	14779-1	Blade tension cap gauge
RHS10S	Round head screw, 10-32 x 3/4, SS	14780	Blade tension adjustment housing
RHS20S	Round head screw, 10-32 x 1 1/8, SS	14781	Blade tension adjustment handle
RHS30S	Round head screw, 1/4-20 x 3/8, SS	14782	Blade tension screw, SS
SSS05S	Set screw, cup, 10-24 x 3/8, SS	14783	O-ring for blade tension screw
SSS15	Set screw, 5/16-18 x 5/16, cup point	14785	Plastic washer
SSS15S	Set screw, 5/16-18 x 5/16, SS cup point	14786	O-ring for gauge
SSS20	Set screw, 3/8-16 x 3/8, knurled cup point	14787	Tension screw top collar
S1007	Channel bracket, SS (3334-4003 only)	14789	O-ring, washer retention
S1120EZ	Channel, SS (3334-4003 only) EZ-Flow	151	Conduit, watertight, per inch
S116-22	Saw guide bar, 22" SS	16Z	Lower gde. brkt. saw cleaner holder
S12214B	Side platter bracket	16003-6	Lower wheel
S155-11	Meat carriage stop thumb screw, SS	16003DF-6	Lower wheel, double flange
S155EZ-3	Hex standoff - EZ Flow carriage	16003U-6	Upper wheel
S16005E	Head, fixed, SS	16003UDF-6	Upper wheel, double flange
S16005E-PX	Fixed head, w/push button enclosure	16015-11	Adj. motor base plate
S16005E-PX-1	Cover, push button enclosure	16015-2	Motor base plate stud nut
S16006E	Head door, fixed head, SS	16015-3	Motor base plate wing nut
S16007	Channel bracket SS	16015-4	Motor base plate lock washer
S16015-1	Motor base plate adjusting stud, SS	16015-10	Motor base plate, 1PH
S16120	Channel, SS	16015-12	Motor base plate, special
S16217L	Left base panel, SS	16112	Head door latch
S16217LTP	Left tapered base panel, SS	16132	Saw cleaner brkt holder rear
S16217R-3	Right hinged base door, SS	16133	Fastener knob, 4 point
S16239-4	Base, fixed head, SS (NSS)	16154-CE	Table extension
S16272	Meat gauge gear rack, SS	16155	Meat carriage top & angle
S16273	Meat gauge bracket SS (order AS16273)	16155EZ	Meat carriage top & angle, EZ flow
S16275	Meat gauge plate, SS		

PART NUMBERS AND DESCRIPTIONS (Cont.)

Item No.	Description	Item No.	Description
16155-13	Carriage stop angle SS	237	Up shaft castellated lock nut
16155-2A	Meat carriage guide	238	Up shaft castld lock nut washer
16155-2B	Meat carriage guide spacer $\frac{1}{64}$	242R	Base door lock, right
16155-2C	Meat carriage guide spacer $\frac{1}{32}$	247	Upper shaft
16159	Meat carriage bearing	248	Upper wheel hub cap
16163A	Platter hold down clip	249	Base door lock handle
16163B	Platter neck guard, SS	252X	Shaft lock nut
16200	Carriage stop movable	256P	Safety pusher plate
16212	Platter latch	264-1	Meat gauge release hand wheel
16220-1	Carriage stop fixed	264-1S	Hand wheel shim
16226A-6	Switch button speed nut	264G	Hand wheel groove pin
16232	Scrap bucket	267	Meat gauge release cotter pin
16239-16	Base interlock plte, SS, England	270	Meat gauge release pin
16251AL	Upper v-belt pulley 11.4 x 1	271AL	Meat gauge worm gear
16251-11X78AL	Pulley, 11.4 x $\frac{1}{8}$, aluminum	272-7-1	Knob, 3-point, $\frac{3}{16}$ -18
16251-90X78AL	Pulley, 9 x $\frac{1}{8}$, aluminum	272-8	Cap nut, $\frac{5}{16}$ -18, SS
16278	Meat gauge arm	272-9	Hex bolt, $\frac{5}{16}$ -18 x 2, SS
16296-2	Switch bracket, SS	272-12	Brass ball, $\frac{7}{32}$ dia.
16301	Model & S/N plate	272-13	Hex bolt, $\frac{5}{16}$ -18 x 1 $\frac{1}{4}$
16302HT	Saw blade, hard tooth, 124"	272-14	Castle nut, $\frac{5}{16}$ -18, SS
16303	Lower shaft nut	277	Lower shaft key
16313FH-305	Owner/operator manual	280	Motor shaft key
16360	Lower bearing housing	300	Lower shaft woodruff key
16361	Lower shaft	310	Waved washer
16501	Rubber motor mount 1PH	311	Rubber bumper – fixed stop
16502	Motor mount washer 1PH	311-1	Rubber bumper – movable stop
16508	Motor mount star washer 1PH	324	Motor shim $\frac{1}{16}$ " thick
16517	Inner race spacer	324A	Motor shim $\frac{1}{8}$ " thick
16543	Lower shaft for removable wheel	331	Platter bracket bumper
16547	Lower bearing housing	360A1	Angled grease fitting
16560	Lower removable wheel	360B-1	Set screw, $\frac{1}{2}$ -13
16560DF	Lower removable wheel, double flange	362	Lower bearing housing adjusting cap
16662	Safety saw guard for SS head	374	Shell Cassida grease EPS-2
16662-COS	Safety saw guard, Costco	375	Drive screw, nameplate
17211-22	Finger lift shim .022	376	Drive screw # 10 x $\frac{1}{2}$
17211-35	Finger lift shim .035	4-30AL	Motor pulley, single-V 5 x $\frac{3}{4}$ bore
175-1-S	Thumb guard nut, SS	4-35AL	Motor pulley, single-V 5 x $\frac{5}{8}$
175-2-S	Thumb guard screw $\frac{1}{4}$ -20 x $\frac{1}{2}$	4-45AL	Motor pulley, single-V 6 x $\frac{3}{4}$ bore
175S	Thumb guard, nylon	4-49AL	Motor pulley, single-V 6 x $\frac{7}{8}$ bore
177	Nylon filler in stationary bar	415D	Stationary bar
179	Wheel cleaner	513	Upper wheel hub cap gasket
18120EZ-B3	Guide bar, EZ flow, T-shaped	530	Retaining ring
193	Saw guide bar spring	55178	Plunger pin, blade tension handle
194	Saw guide bar lock pad, brass	601	Upper guide bracket
194KS-1	Saw guide bar lock knob	602B	Upper blade back up guide
196-2	Blade tension spring, fixed head	602AFSC	Upper blade back up guide, narrow
211	Finger lift bracket	605	Lower blade back up guide
211A-291Q	Fastener knob, $\frac{3}{8}$ -16 x 4 point	653PC-E	Warning label, English
221-52	V-belt, 52"	653PC-FR	Warning label, French
228-2	Lower saw guide washer $\frac{1}{4}$ x 1 O.D.	653PC-SP	Warning label, Spanish
230DL	Upper shaft seal, double lip	706SW	Saw warning notice tag – orange
231DL	Lower shaft seal, double lip	708	Danger Exposed Blade decal
234	Grease fitting upper wheel	800H-FRXN6A7-PX	Push button 3-pos. mom. in & out

COMPLETE ASSEMBLIES FOR MODELS 3334FH & 3334-4003FH

Item No.	Description	Item No.	Description
AS1120EZ	Channel assembly (3334-4003) EZ Flow	A16132	Steel cleaner assembly – rear
AS16006E	Head door assembly	A16155	Meat carriage assembly
AS16120	Channel assembly	A16155EZ	Meat carriage assembly, EZ flow
AS16120EZ	Channel assembly, EZ Flow	A16163-1	Stationary platter assembly
AS16217R	Hinged base door – old style	A16200	Carriage stop assembly, movable
AS16217R-3	Hinged base door – new style	A16220-1	Carriage stop assembly, fixed
AS16273	Meat gauge bracket assembly	A16278	Meat gauge plate assembly, less release
AS16273-S275	Meat gauge assembly	A16360	Lower bearing housing assembly w/o wheel
AS16275	Meat gauge plate assembly	A16361	Lower shaft bearing assembly
AS16290	Cleaning unit stamping assembly	A16547	Lower bearing housing assembly for removable wheel
AS16335XE	Upper hinge plate assembly, fixed head	A175S	Thumb guard assembly
AS415D	Stationary bar assembly, SS	A181155EZ	Meat carriage assembly (3334-4003) EZ Flow
A116-22-COS	Saw guide bar assembly, 22" Costco	A211-COS	Finger lift assembly, removable, special
A116-22SS	Saw guide bar assembly	A211-SS	Finger lift assembly, removable SS
A130	Steel cleaner assembly	A227	Upper bearing cup/cone assembly
A14787	Blade tension spring – screw assembly	A247	Upper shaft and bearing assembly
A16Z	Guide bracket saw cleaner assembly	A247-1	Upper shaft brg. assembly w/o wheel & spacer
A16003U-6	Upper wheel assembly, w/o hinge plate	A249R	Base door lock assembly, right
A16003UDF-6	Upper wheel assembly, double flange, w/o hinge plate	A262	Meat gauge release assembly
A16003U335-6E	Upper wheel assembly w/hinge plate	A295	Wheel cleaner assembly
A16003UDF335-6E	Upper wheel assembly w/hinge plate, double flange	A363	Lower bearing cup/cone assembly
A16112	Head door latch assembly	A415D	Stationary bar assembly
		A602	Saw guide assembly, upper

**WEARABLE SAW PARTS THAT WILL FIT BIRO POWER CUTTERS
MODELS**

11-22-1433-33-34-3334-44-4436-55

— EXCEPT WHERE NOTED OTHERWISE —

**CONTACT YOUR NEAREST BIRO AUTHORIZED DISTRIBUTOR
OR CONTACT BIRO MANUFACTURING**

Ph.: 419-798-4451 E.Mail: service@birosaw.com

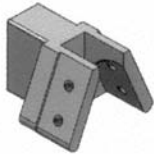

**Item No. 130
SAW CLEANER BRACKET
ALL SAWS**



**Item No. 131
STEEL BLADE CLEANER
ALL SAWS**



**Item No. 159
CARRIAGE BEARING
11-22-33**



**Item No. 16159
CARRIAGE BEARING
1433-34-3334-44-55**

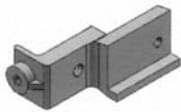

**Item No. 601
UPPER SAW GUIDE BRACKET
ALL SAWS**

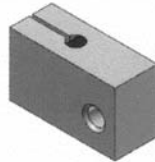

**Item No. 602B
UPPER SAW GUIDE
W/BEVELED CARBIDE
ALL SAWS**



**Item No. S265
MEAT GAUGE SPRING
ALL SAWS**



**Item No. S608
LOWER BLADE BACKUP
W/CARBIDE
22 (after S/N 35301)-1433-55**



**Item No. 119A
LOWER SAW GUIDE
ALL SAWS**

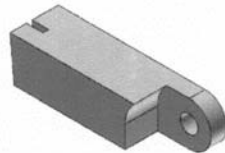

**Item No. 177
NYLON FILLER
ALL SAWS**

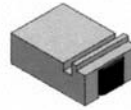

**Item No. 604
LOWER BLADE BACKUP
W/CARBIDE
11-22 (before S/N 35300)**



**Item No. 605
LOWER BLADE BACKUP
W/CARBIDE
34-3334-44-4436**

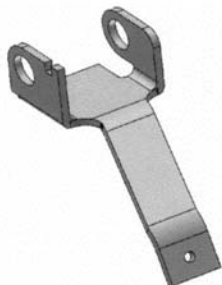

**Item No. S295
WHEEL CLEANER ARM
ALL SAWS**

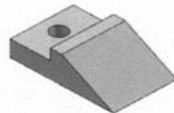

**Item No. 179
WHEEL CLEANER
ALL SAWS**



**Item No. S244
WHEEL CLEANER ARM STUD
ALL SAWS**



**Item No. S229
WHEEL CLEANER
ARM SPRING
ALL SAWS**



**Item No. S268
FILLER & GUIDE STUD
ALL SAWS**

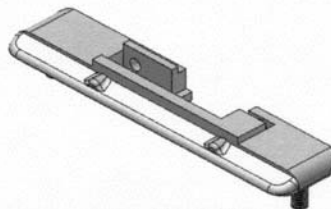

**Item No. 415D
STATIONARY BAR
ALL SAWS**

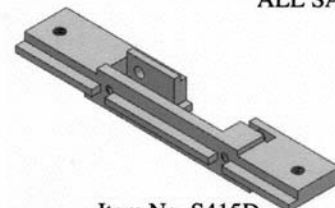

**Item No. S415D
STAINLESS STATIONARY BAR
STD: 22 (after S/N 35301)-1433-55
OPT: 3334-44**

— USE PARTS REPAIR KIT PART NO. 16700 —

OPERATOR'S SIGNATURE PAGE

WARNING
**READ AND UNDERSTAND THIS ENTIRE
MANUAL BEFORE SIGNING BELOW**

MY SIGNATURE ATTESTS THAT I HAVE COMPLETELY READ AND UNDERSTAND THIS MANUAL. I REALIZE THAT THIS MACHINE, IF OPERATED CARELESSLY, CAN CAUSE SERIOUS INJURY TO MYSELF AND OTHERS.

NAME (PRINT)	SIGNATURE	SUPERVISOR'S INITIALS	DATE

LIMITED WARRANTY:

WARRANTY: The BIRO Manufacturing Company warrants that Models 33334FH & 3334-4003FH will be free from defects in material and workmanship under normal use and with recommended service. BIRO will replace defective parts, which are covered by this limited warranty, provided that the defective parts are authorized for return, shipping charges prepaid, to a designated factory for inspection and/or testing.

DURATION OF WARRANTY: The warranty period for all parts covered by this limited warranty is one (1) year from date of Inspection/Demonstration advised on the returned Warranty Registration card, or eighteen (18) months from original factory ship date, whichever occurs first, except as noted.

PARTS NOT COVERED BY WARRANTY: The following are **not** covered by this limited warranty: wearable parts on the cleaning system such as wheel cleaners (Item No. 179), saw cleaners (Item No. 131), blade backup guides (Item No's. 602B, 605 & 119A), and the nylon filler (Item No. 177). This limited warranty does not apply to machines sold as used, rebuilt, modified, or altered from the original construction in which the machine was shipped from the factory. (WATER CONTAMINATED ELECTRICAL SYSTEMS ARE NOT COVERED UNDER THIS LIMITED WARRANTY.) BIRO is not responsible for electrical connection of equipment, adjustments to switch controls or any other electrical requirements, which must be performed only by a certified electrician. BIRO is not responsible for service charges or labor required to replace any part covered by this limited warranty or for any damages resulting from misuse, abuse, lack of proper or recommended service.

EXCLUSION OF WARRANTIES AND LIMITATION OF REMEDIES: BIRO gives no warranties other than those expressly stated in this limited warranty. THE IMPLIED WARRANTY OF MERCHANTABILITY, THE IMPLIED WARRANTY OF FITNESS FOR PROCESSING FOOD PRODUCTS, AND ALL OTHER IMPLIED WARRANTIES ARE SPECIFICALLY EXCLUDED. BIRO IS NOT LIABLE FOR CONSEQUENTIAL OR INCIDENTAL DAMAGES, EXPENSES, OR LOSSES. THE REMEDIES PROVIDED IN THIS BIRO LIMITED WARRANTY ARE PURCHASER'S SOLE AND EXCLUSIVE REMEDIES AGAINST BIRO.

REGISTRATION CARDS: You must sign, date and complete the warranty registration card supplied with each machine. The warranty card must be returned to The Biro Manufacturing Company for proper registration. If no warranty card is returned to BIRO, the warranty period will begin from the date the machine was originally shipped from the factory.

HOW TO GET SERVICE:

1. Contact the entity from whom you purchased the machine; or
2. Consult the yellow pages of the phone directory for the nearest authorized dealer; or
3. Contact BIRO Mfg. Co. for the authorized service entity (250 plus worldwide) in your area.

THE BIRO MANUFACTURING COMPANY

1114 Main Street
Marblehead, Ohio 43440-2099
Ph. 419-798-4451
Fax 419-798-9106
E-mail: service@birosaw.com
Web: <http://www.birosaw.com>