

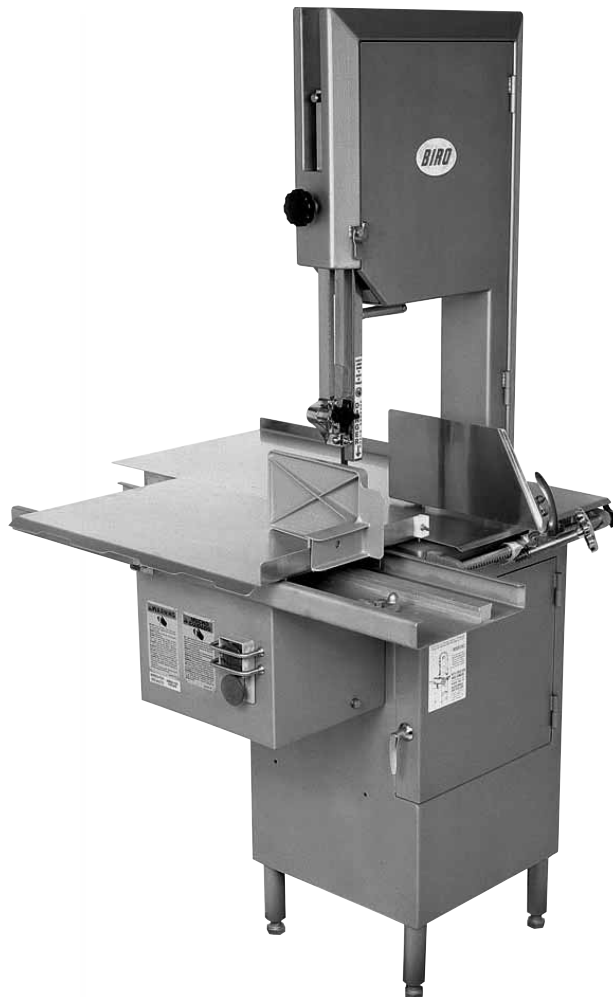

**MODEL 1433FH
FIXED HEAD
POWER MEAT CUTTER
OPERATING AND SERVICE MANUAL**



☆ IMPORTANT NOTICE ☆

This Manual contains important safety instructions which must be strictly followed when using this equipment.

ITEM No.: 14313FH-304
MD 1433FH 7-14-11 PPD

TABLE OF CONTENTS

	Page
NOTICE TO OWNERS AND OPERATORS	1
SAFETY TIPS.....	2
INSTALLATION	3-7
WARNING LABELS FOR POWER CUTTERS	8
WARNING LABELS LOCATIONS ON MACHINE	9
BAND SAW SAFETY GUIDELINES	10
OPERATION.....	11
FOOD HANDLING TO PREVENT CONTAMINATION	11
TO PROCESS PRODUCT	12
MAINTENANCE	13
GENERAL.....	13
LUBRICATION.....	14
OPERATOR'S NOTES	15
PARTS DIAGRAMS.....	16-25
BASE DOOR HINGE SYSTEM.....	21
SWITCH ASSEMBLIES AND SERVICE PARTS.....	25
OPERATOR'S NOTES	26
WIRING DIAGRAMS	27-32
CLEANING PROCEDURE	33
WEARABLE SAW PARTS LIST	34
PARTS LIST ORDERING	35
PARTS ASSEMBLIES LIST/ORDERING	36
OPERATOR'S SIGNATURE PAGE	37
LIMITED WARRANTY	38

NOTICE TO OWNERS AND OPERATORS

BIRO's products are designed to process food products safely and efficiently. Unless the operator is properly trained and supervised, there is the possibility of a serious injury. It is the responsibility of the owner to assure that this machine is used properly and safely, strictly following the instructions contained in this Manual and any requirements of local law.

No one should use or service this machine without proper training and supervision. All operators should be thoroughly familiar with the procedures contained in this Manual. Even so BIRO cannot anticipate every circumstance or environment in which its products will be used. You, the owner and operator, must remain alert to the hazards posed by the function of this equipment – particularly the SHARP MOVING BAND TYPE SAW BLADE. No one under eighteen (18) years of age should operate this equipment. If you are uncertain about a particular task, ask your supervisor.

This Manual contains a number of safe practices in the SAFETY TIP section. Additional warnings are placed throughout the Manual. Warnings related to your personal safety are indicated by:



OR



Warnings related to possible damage are indicated by:



BIRO also has provided a wall chart to be posted near the equipment. If any warning label, wall chart, or Manual becomes misplaced, damaged, or illegible, please contact your nearest Distributor or BIRO directly for a replacement.

Remember, however, this Manual or the warning labels do not replace the need to be alert and to use your common sense when using this equipment.

This Manual applies to 1433FH Power Meat Cutters with Fixed Heads.

– NOTE –

“A copy of this manual is included with each MODEL 1433FH SAW.”

“The descriptions and illustrations contained in this manual are not binding. The manufacturer reserves the right to introduce any modification without updating the manual.”

SAFETY TIPS

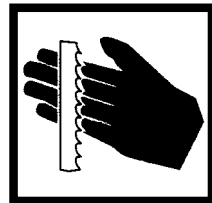

SHARP MOVING BAND TYPE SAW BLADE TO AVOID SERIOUS PERSONAL INJURY

- NEVER** Touch This Machine Without Training and Authorization By Your Supervisor.*
- ALWAYS** Read Operation and Parts Manual **BEFORE** Operating, Cleaning or Servicing.*
- ALWAYS** Keep Hands Clear of Sharp Band Type Saw Blade and Other Moving Parts.*
- ONLY** Use a Qualified Electrician to Install According to Local Building Codes: Machines **MUST** Be Properly Grounded.*
- ONLY** Install on Level, Non-Skid Surface in a Clean, Well-Lighted Area Away From Children and Visitors.*
- DO NOT** Attempt to Operate This Machine Until it has Been Inspected and Demonstrated by the Seller – Recognized **BIRO** Representative.*
- DO NOT** Alter or Modify This Machine in any Way From its Original Form. This Machine in its Original Form Meets the Intent of O.S.H.A. Applicable Standards.*
- NEVER** Operate with Saw Guard on Saw Guide Bar in the Raised Position or the Saw Guard Removed from the Saw Guide Bar.*
- ALWAYS** Adjust the Saw Guide Bar with Saw Guard to Within ½" of Product to be Cut.*
- ALWAYS** Use Supplied Safety End Cut Pusher Plate for Smaller Products or The Last Cuts of Product.*
- DO NOT** Use This Machine for Non-Food Products.*
- DO NOT** Use This Machine to Cut Pigs Feet.*
- DO NOT** Wear Gloves While Operating.*
- ALWAYS** Turn Off, Unplug From Power Source and Perform Lockout/Tagout Procedure to This Machine **BEFORE** Removing Shrouds, Removable Guards, Covers, Doors, Fences or Panels for Cleaning, Servicing or Any Other Reason.*
- NEVER** Leave Machine Unattended While Operating.*
- PROMPTLY REPLACE** Any Worn or Illegible Warning Labels.*
- USE ONLY BIRO** Parts and Accessories Properly Installed.*

INSTALLATION



TO AVOID SERIOUS PERSONAL INJURY PROPERLY INSTALL EQUIPMENT IN ADEQUATE WORK AREA

ALWAYS Read Operating and Parts Manual **BEFORE** Installation.

ALWAYS Use Qualified Technician and Electrician for Installation.

ALWAYS Install Equipment in Work area with Adequate Light and Space.

ONLY Operate on a Solid, Level, Non-Skid Surface.

DO NOT Attempt to Operate This Machine Until It has been Inspected and demonstrated by the Seller – Recognized BIRO Representative.

DO NOT Alter or Modify This Machine in Any Way from its Original Form. This Machine in its Original Form Meets the Intent of O.S.H.A. Applicable Standards.

NEVER Operate with Saw Guard on Saw Guide Bar in the Raised Position or the Saw Guard Removed from the Saw Guide Bar.

ALWAYS Adjust Saw Guide Bar with Saw Guard to Within $\frac{1}{2}$ " of Product to be Cut.

NEVER Operate Without all Warning Labels Attached and Wall Chart Posted.

USE ONLY BIRO Parts and Accessories Properly Installed.

1. Read this Manual thoroughly before installation and operation. **Do not** proceed with installation and operation if you have any questions or do not understand anything in this Manual. Contact your local Distributor, or BIRO first.
2. Install machine on a level, solid, non-skid surface in a well-lighted work area away from children and visitors.



ALWAYS LEVEL MACHINE BEFORE USING

3. After installing machine in operational area, it is imperative that the four adjusting leg hex bolts be adjusted to level the machine.
4. To assemble meat gauge plate (Part No. A14275) to the machine; Loosen the lock knob (Part No. 272-10) on the right side of the meat gauge bracket. Remove the meat gauge gear rack (Part No. 14272) and insert into the meat gauge plate. Be sure to hold meat gauge arm so that the release handle is depressed. Re-install the gear rack by first inserting the rectangle end into the left hand meat gauge bracket, then swing the right hollow round end of the gear rack into the original lock position. Upon aligning the gear rack with the capscrew (Part No. 272-11), tighten the lock knob clockwise, fastening the locking cap screw into the hollow end of the gear rack, **CHECKING** for a secure assembly. Keep gear rack well oiled with food grade oil to insure free movement.

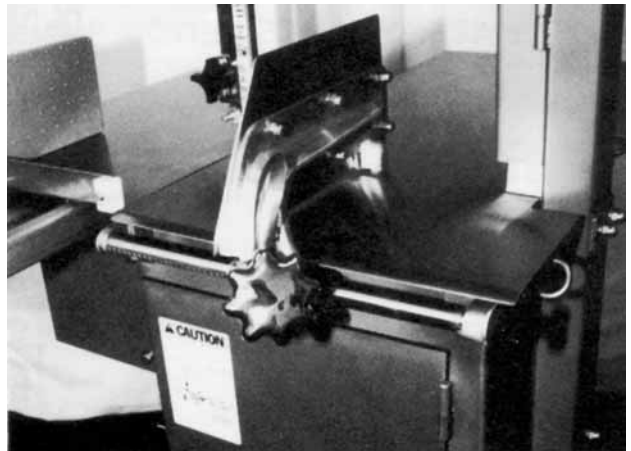

- Place removable finger lift with saw guard assembly (Part No. A14211) on the saw guide bar (Part No. 116-22) and fasten to place with finger lift fastener knob (Part No. 211A-291Q).
- See Lower Removable Wheel Installation and Removal Instructions for Model 1433 below.

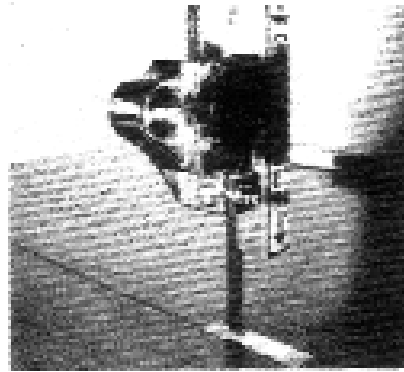

FINGERLIFT ASSEMBLY

REMOVAL and INSTALLATION
for Self-Centering Lower Removable Wheels
(Part No. 14560-1 and 14560DF-1)

ALWAYS Turn Off, Unplug Machine From Power Source and Perform Lockout/Tagout Procedure to the Machine BEFORE Cleaning or Servicing.

Follow disassembly procedures in the Cleaning Section of the Operating and Service Manual. Removal of the T-Handle and Lower Wheel will be the last 2 parts removed in the number sequence.

REMOVAL

Loosen Item No. 14746-1, T-Handle Lock and Remove from Lower Shaft.



Using both hands (@ 3 and 9 o'clock Positions), Pull wheel towards you with a even smooth motion.



INSTALLATION

There is a anti-rotation pin located on the lower shaft, there is a anti-rotation groove located on the back side of the lower wheel.

Align and engage the groove of the lower wheel and the anti-rotation pin as the wheel is being installed.

Install T-Handle Lock onto Lower Shaft. Hand Tighten **SECURELY**

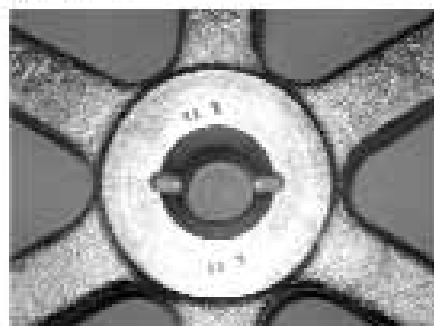

REMOVAL and INSTALLATION INSTRUCTIONS
for TAPERED BORE LOWER WHEELS
#14560 and #14560DI'

ALWAYS Turn Off, Unplug from Power Source, and Perform Lockout/Tagout Procedure to the Machine **BEFORE** Cleaning or Servicing.

Follow Disassembly Procedures in the Cleaning Section of the Operating and Service Manual. Removal of the Lower Wheel will be last procedure.

REMOVAL

Loosen the Item No. 14746 T-Handle Lock, **DO NOT REMOVE COMPLETELY FROM SHAFT.**

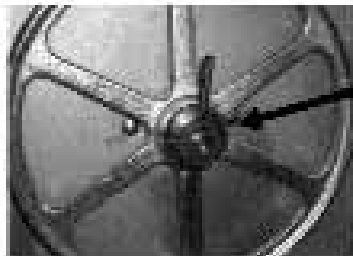

14746
T-Handle Lock



**T-HANDLE
LOOSENED**

Using thumbs for leverage, pull wheel toward you with an even smooth motion. Wheel is mounted in slip fit fashion on a tapered shaft. When the wheel is loose, complete removing T-handle lock and wheel.



14746
T Handle Lock

INSTALLATION



There is an alignment pin on the lower shaft. And a mating alignment groove in the hub of the lower wheel. Align the two as the wheel is being installed on the tapered shaft.

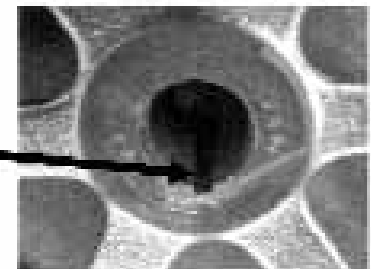

NOTE:
**TO ENSURE PROPER SAW WHEEL
ALIGNMENT, WHEEL MUST BE
REINSTALLED ON SAME
MACHINE FROM WHICH IT WAS
REMOVED.**

Replace the T-Handle Lock
HAND TIGHTEN ONLY
Reassemble the machine.

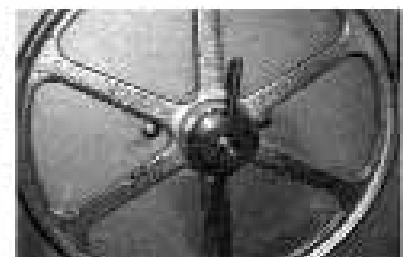

Item No. 16543 – Lower Shaft for Removable Wheel

6. The Model 1433 Lower Removable Wheel has been revised to include a keyway in the bore. Also an anti-rotation pin is now pressed into the lower shaft to prevent any inadvertent "spinning" of the wheel on the shaft.

NOTE – If the saw in which a new shaft is to be installed has a groove (keyway) in the bore of the lower wheel, press the taper pin (provided "loose") into the hole in the side of the shaft (see sketch).

If there is no groove (keyway) in the bore of the lower wheel, discard the taper pin and use the shaft without the pin.

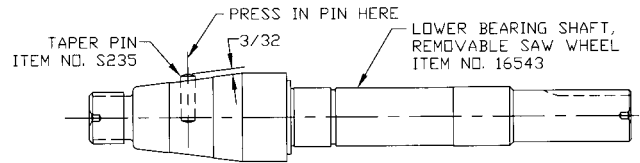

7. The side platter bracket (Part No. S14214) is packed loose in the machine and must be installed on the left side of the base structure with the supplied hardware and checked for proper adjustment. Stationary platter must be flat.
8. Machine **MUST** be properly grounded. Use qualified electrician to install according to building codes.

WIRING MOTOR

- (1) Interchange of motor current is made in motor outlet box. Leads are properly marked. Changing instructions are on motor plate or inside junction box cover.
- (2) All saws are wired 220 volts unless otherwise specified. Be sure motor specifications (voltage, cycle, phase) match power supply line. Be sure line voltage is up to specification.
- (3) Connect leads to machine in a manner that will be approved by local electrical inspectors.
- (4) We recommend no less than No. 12 wire. If the leads are too light, machine may not have sufficient cutting power and/or speed.
- (5) The drive belt is packed loose in machine to prevent deformation, and must be installed on pulleys at time of wiring motor.
- (6) The BIRO Manufacturing Company is not responsible for permanent wiring, connection or installations.



NOTE TO OWNER AND ELECTRICIAN: IF THIS MACHINE IS NOT CORD AND PLUG CONNECTED TO THE ELECTRICAL SUPPLY SOURCE, THEN IT SHOULD BE EQUIPPED WITH, OR CONNECTED TO, A LOCKABLE, MANUALLY OPERATED DISCONNECT SWITCH (OSHA 1010.147).

9. All machines are tested at the factory, but electrical phasing for proper rotation may not match your electrical supply. All machines with removable lower wheel must be first test run for proper phasing with the lower wheel removed. Failure to remove the lower wheel could cause the wheel to become dislodged during testing. All machines with removable lower wheel will display the following decal on the right hinged base door.



**** This saw has been equipped with a "REMOVABLE" lower wheel ****

**ATTENTION: ELECTRICIAN / SERVICE TECHNICIAN
** READ FIRST BEFORE STARTING POWER CUTTER ****

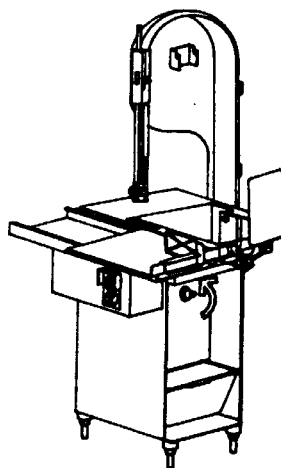

IMPORTANT

This saw has been electrically tested at the factory, but electrical phasing for proper rotation may not match your electrical supply.

WITH LOWER SAW WHEEL REMOVED, check rotation of shaft. Rotation must be counterclockwise when facing shaft. Failure to confirm correct rotation could result in the wheel dislodging.



SHARP SAW BLADE. HANDLE WITH EXTREME CAUTION.

10. Placing blade on cutter: Unpack upper wheel assembly and hang on the hinge bracket in the head structure. Lift the nylon filler in the stationary bar. Hang the blade on the upper wheel and hold with right hand. With the left hand force the back of the blade between the front blade scrapers, located below the stationary bar. Lower the nylon filler. Be sure the blade is in the upper saw guide. The blade has dropped over the lower wheel. Switch hands holding the blade on the upper wheel. With the right hand, force the blade between the rear blade scrapers. The blade is now ready to be tightened.
11. Turn the blade tensioning handle clockwise until the tension mark is even with the bottom of the upper wheel hinge plate as shown. Carefully turn saw wheels by hand and watch for proper tracking of blade on the wheels.

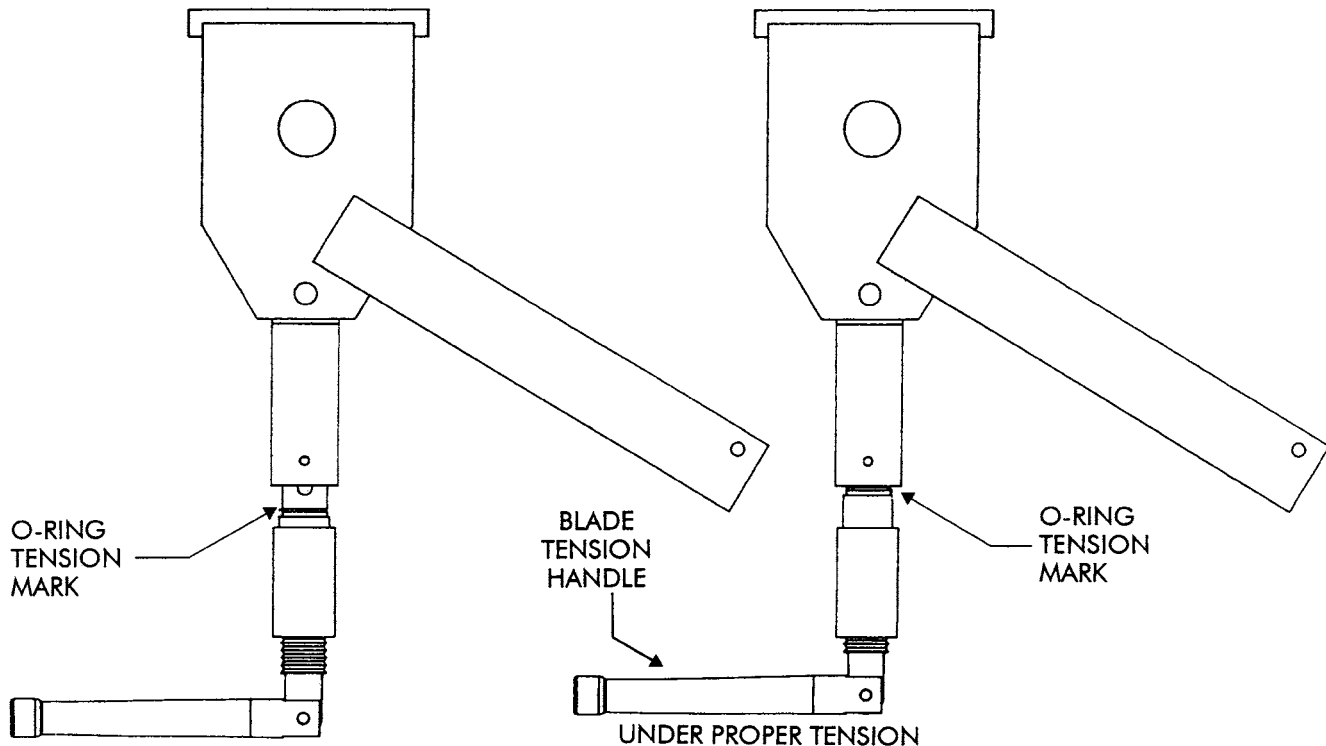

12. The stationary platter (Part No. A14163) is placed on top of the base structure and held in place by two push-pull hold down rods (Part No. 14212W), located at the rear of the base.
13. The sliding meat carriage assembly (Part No. A16155EZ) is installed by turning the movable stop assembly (Part No. A16200) clockwise. After the carriage assembly is in the channel for operation, turn the movable stop counterclockwise to lock.
14. Make sure saw guide bar with saw guard is in its lowest position. Close head and base doors.



KEEP HANDS CLEAR OF SHARP MOVING BAND TYPE SAW BLADE

15. Push the start button. Check for proper phasing of the motor and proper tracking of the saw blade in the saw guides. Back of the blade should be centered in the lower saw guide (Part No. 119A) in the stationary bar. Blade should be moving down through the guide. Push the stop button to stop the machine.
16. Check placement of all warning labels, wall chart and Manual. Machine is ready for trained operators to process product. Post SAFETY TIPS wall chart within easy view of operator. Keep Manual available to operator.
17. Contact your local Distributor or BIRO directly if you have any questions or problems with the installation or operation of this machine.

WARNING LABELS FOR BIRO POWER CUTTERS



WARNING



DO NOT Use Unless Trained and Authorized By Supervisor And Over 18 Years Old.

Read Operation Manual Thoroughly Before Operating.

ALWAYS Keep Hands Clear of Saw Blade and Other Moving Parts. Turn Off Saw when Finished Cutting.

ALWAYS Keep Blade Guard Adjusted to 1/2" Above the Product being Cut.

ALWAYS Use End Cut Pusher Plate When Cutting Smaller Piece of Product.

DO NOT Use Saw if it is Altered, Damaged, Improperly Maintained, or If Warnings Are Illegible or Missing.

ALWAYS Disconnect and Unplug from Main Power Source and Perform LOCKOUT/TAGOUT Before Cleaning or Servicing.

#653PC-E

ITEM No. 653PC-E: ALL SAWS
1 ea. Attached to Head Below S/N Plate
1 ea. Attached to Channel Bracket



MUCHO CUIDADO



NO Opere Esta Sierra Sin Haber Sido Entrenado Para Ello Ni Tampoco Sin Autorizacion de un Supervisor. Uno Tiene que Haber Cumplido 18 Anos Para Operarla.

LEA Cuidadosamente el Manual de Operacion Antes de Usar Este Equipo.

SIEMPRE Guarde las Manos a Salvo de la Hoja de Serrar y de Otras Partes Moviles. Cirre el Interruptor Despues de Terminar de Cortar.

SIEMPRE Tenga Ajustado el Guardasierra Para que quede a 1/2" Por Encima del Producto que se Corta.

SIEMPRE Haga Uso de la Placa de Empuje Para Cortes de Extremos al Cortar Trocitos Pequenos.

NO Utilice la Sierra si se Halla Alterada, Danadao si No ha Sido Debidamente Mantenido o si la Advertencia es Alegible o si Falta Esta.

SIEMPRE Desconecte el Equipo Decenchifandolo de la Fuente de Fuerza. Dejelo Bajo Llave o con Etiqueta que Prohiba su Uso Antes de Limpiarlo o Hacer Trabajos de Mantenimiento.

#653PC-SP

ITEM No. 653PC-SP: ALL SAWS
1 ea. Attached to Channel Bracket

★ ★ ★ NOT TO SCALE ★ ★ ★



CAUTION

** This saw has been equipped with a "REMOVABLE" lower wheel **

ATTENTION: ELECTRICIAN/SERVICE TECHNICIAN
** READ FIRST BEFORE STARTING POWER CUTTER **

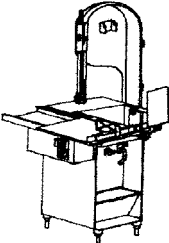

IMPORTANT

This saw has been electrically tested at the factory, but electrical phasing for proper rotation may not match your electrical supply.

WITH LOWER SAW WHEEL REMOVED check rotation of shaft.

Rotation must be counterclockwise when facing shaft.

Failure to confirm correct rotation could result in wheel dislodging.

ITEM No. 708: ALL SAWS
Attached to saw Guard
on Saw Guide Bar

ITEM No. 16716
Applied to Right Hinged Base Door
on All Model 1433 and Model 3334
with Lower Removable Wheel

**ALWAYS
LOWER
GUARD
TO
HEIGHT
OF
PRODUCT**



**D
A
N
G
E
R**

**E
X
P
O
S
E
D
B
L
A
D
E**



WARNING LABEL LOCATIONS ON MACHINE

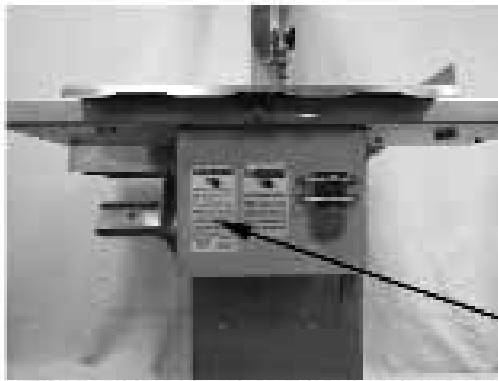

ATTACH TO CHANNEL BRACKET NEXT TO SWITCH BUTTONS



ATTACH ON HEAD STRUCTURE BELOW MODEL/SERIAL NUMBER TAG



P/N 729 BLADE TENSION ADJUSTMENT DECAL

LOCATED INSIDE HEAD DOOR

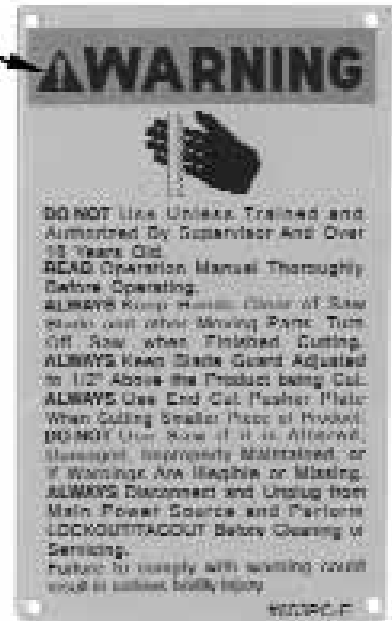
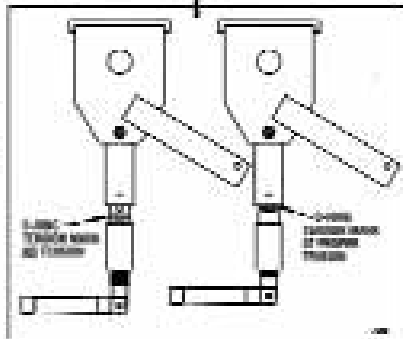

P/N 708 "DANGER EXPOSED BLADE" DECAL

ATTACHED TO SAW GUARD ON SAW GUIDE BAR



P/N 16716 "CAUTION" LABEL USE ON MACHINES WITH REMOVABLE LOWER WHEEL

ATTACH TO HINGED RIGHT BASE DOOR

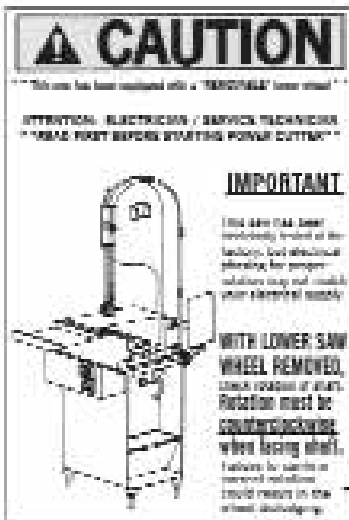

ITEM No. 671
WALL CHART "BAND SAW SAFETY GUIDELINES"

ATTACH TO WALL IN VICINITY OF MACHINE IN EASY VIEW OF OPERATOR



WARNING

ONLY PROPERLY TRAINED PERSONNEL SHOULD USE THIS EQUIPMENT

**This Saw Contains A Sharp Blade.
To Reduce Risk of Injury:**

1. Before Using, Make Sure:

- Gauge Plate (A) And Other Components Are Secure.
- All Warning Labels and Guards Are In Place.
- The Guide Bar (B) Is Adjusted To $\frac{1}{2}$ Inch Above The Product To Be Cut.

2. While Cutting:

- Keep Hands and Fingers Away From Blade.
- Keep Product Securely Against Gauge Plate.
- Use End Cut Pusher (C) When Making Final Cuts. Item No. 256P.

3. Before Cleaning:

- Turn Off Power And Unplug.
- Remove Saw Blade.
- Use Extra Care When Handling The Saw Blade.

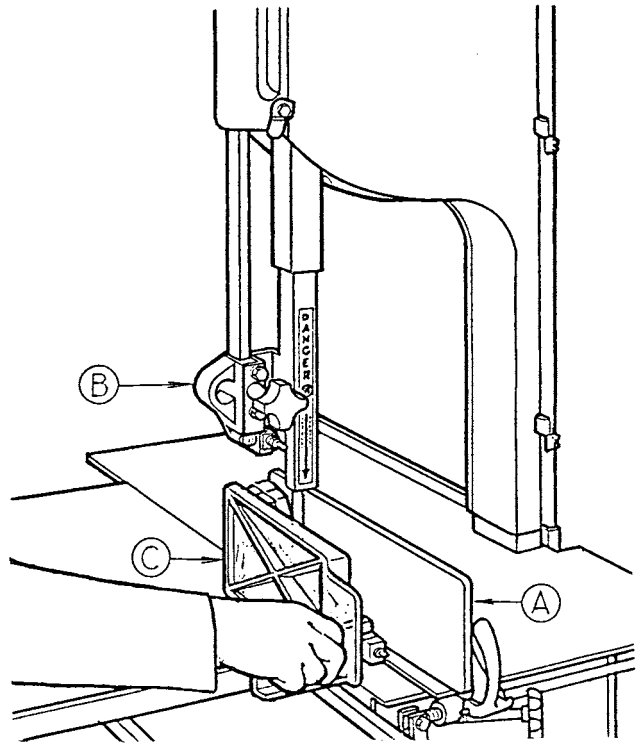

USE YOUR BIRO MEAT SAW SAFELY!

SEE PARTS AND SERVICE MANUAL SUPPLIED WITH MACHINE FOR ADDITIONAL SAFETY INFORMATION.

OPERATION

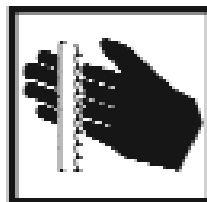

SHARP MOVING BAND TYPE SAW BLADE TO AVOID SERIOUS PERSONAL INJURY

ONLY Properly Trained Personnel Should Use This Equipment.

*ALWAYS Read Operating and Parts Manual **BEFORE** Operating.*

ALWAYS Keep Hands Clear of Band Type Saw Blade and Other Moving Parts.

DO NOT Tamper With, Bypass, Alter, or Modify this Equipment in Any Way or Form.

DO NOT Alter or Modify This Machine in any Way From its Original Form. This Machine in its Original Form Meets the Intent of O.S.H.A. Applicable Standards.

NEVER Operate with Saw Guard on Saw Guide Bar in the Raised Position or the Saw Guard Removed from the Saw Guide Bar.

ALWAYS Adjust the Saw Guide Bar with Saw Guard to Within $\frac{1}{8}$ " of Product to be Cut.

ALWAYS Use Safety End Cut Pusher Plate for Smaller Products or The Last Cuts of Product.

DO NOT Use This Machine for Non-Food Products.

DO NOT Use This Machine to Cut Pigs Feet.

DO NOT Wear Gloves While The Saw is Running.

ALWAYS Turn Off, Unplug from Power Source and Perform Lockout/Tag Out Procedures Before Cleaning, Servicing or When Not in Use.

NEVER Leave Machine Unattended While The Saw is Running.

NEVER Operate Without All Warning Labels Properly Affixed to Machine.

A. FOOD HANDLING TO PREVENT CONTAMINATION

1. **ALWAYS** wash hands thoroughly with warm soap and water before and after handling raw fish, poultry or meats.
2. **ALWAYS** clean and sanitize all utensils and surfaces that have been in contact with raw products.
3. **ALWAYS** store cold foods at or below 45 deg. F (7.2 deg. C).

B. TO PROCESS PRODUCT

1. Before starting power cutter, adjust saw guide bar with saw guard to within ½” of product to be cut. “B”

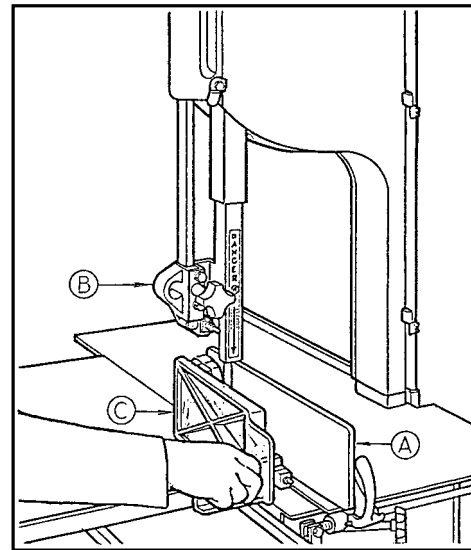
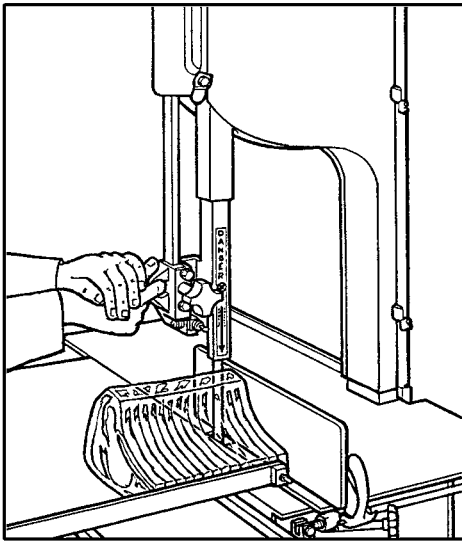

DO NOT WEAR GLOVES WHILE OPERATING

2. Make sure all doors are closed and locked.
3. Adjust meat gauge plate forward to desired thickness of cut. “A”
4. Push start button and watch blade for proper tracking.
5. Standing in front of the power cutter, place product on the meat carriage. Pay attention to position of your hands. Keep hands clear of moving band type saw blade. Leaning lightly against the scalloped front edge of meat carriage, hold the product firmly in right hand with product face flush against the meat gauge plate. Move the meat carriage from right to left at a steady rate until fully past the saw blade. Use left hand to remove and stack cut product, **NEVER REACH IN FRONT OF BAND TYPE SAW BLADE**. On the return stroke, pull the product slightly toward you to clear the blade.



NEVER REACH OR GRAB FOR PRODUCT IN FRONT OF MOVING BAND TYPE SAW BLADE

6. ALWAYS use the Safety End Cut Pusher Plate for smaller products or the last cuts of product. “C”
The pusher plate is supplied as standard on all BIRO power cutters.
7. When finished cutting, push stop button. Perform lockout/tag out procedure.

MAINTENANCE

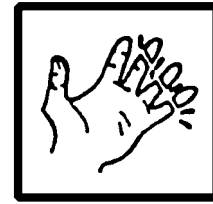
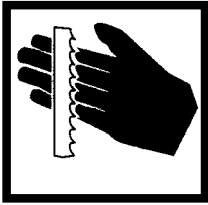

TO AVOID SERIOUS PERSONAL INJURY

ALWAYS Turn Off, Unplug From Power Source and Perform Lockout/Tag Out Procedure to This Machine **BEFORE** Cleaning or Servicing.

NEVER Touch This Machine Without Training and Authorization By Your Supervisor.

ALWAYS Keep Hands Clear of Band Type Saw Blade and Other Moving Parts.

NEVER Bypass, Alter, or Modify This Equipment in Any Way From Its Original Condition.

PROMPTLY REPLACE Any Worn or Illegible Warning Labels.

USE ONLY GENUINE BIRO Parts and Accessories Properly Installed.

A. GENERAL

1. Machine should be generally inspected every time it is cleaned (at least daily) to ensure that it is in good condition and has not been damaged or tampered with.
 - a. **SAW WHEELS:** Clean outer diameter grooves daily. Check for cracks, gouges or wear on the flange and grooves.



**DO NOT IMMERSE UPPER WHEEL
ASSEMBLY IN WATER**

- b. **WHEEL CLEANER ASSEMBLIES:** Check condition of fiber cleaner, change every four (4) weeks. Check condition of tension spring, replace as needed.
- c. **REMOVABLE FINGER LIFT ASSEMBLY:** Check condition of saw guard, make sure mounting bolts are tight and the "DANGER EXPOSED BLADE" decal is affixed and legible. Check condition of upper saw guide (Part No. 602B), replace every 6 months. Check adjustment of upper saw guide. Should be $\frac{1}{32}$ " between back of blade and saw guide carbide.
- d. **SAW GUIDE BAR:** Check condition of bar for wear, replace if necessary.



**NEVER USE THIS MACHINE WITHOUT PROPERLY INSTALLED
AND FUNCTIONING SAW GUIDE BAR AND SAW GUARD**

- e. **STATIONARY BAR ASSEMBLY:** Check condition of nylon filler (Part No. 177), change every four (4) weeks. Check condition of saw guide (Part No. 119A), check tracking of blade through guide, back of blade should be centered in hole, replace every six (6) months. Check condition of lower blade back-up guide (Part No. S608). Check adjustment of back-up guide, should have $\frac{1}{32}$ " gap between back of blade and saw guide carbide. Replace every six (6) months.
- f. **SAW CLEANERS:** Check condition of blade cleaners, replace every 4 weeks.
- g. **MEAT GAUGE ASSEMBLY:** Check free movement of meat gauge plate on gear rack. Gear rack to be kept lubricated at all times with light food grade oil. Check operation of release handle. Check that worm gear engages properly with gear rack. Check tension of release handle spring, replace as necessary.
- h. **MEAT CARRIAGE ASSEMBLY:** Check for free movement through full range of travel. Check side to side for excessive clearance, adjust as necessary. Check condition and grease bearings, replace as necessary. Check condition of thumb guard, replace as necessary.
- i. **SAFETY ITEMS:** Safety end cut pusher plate is with machine and accessible. All warning labels are present, properly affixed and legible. Model and Serial Number plate properly affixed and legible. Wall poster within operator's view from machine. Manual accessible to operator.

B. LUBRICATION

1. **UPPER WHEEL BEARINGS:** Grease every four (4) months. Change grease every twelve (12) months.
2. **LOWER BEARING HOUSING:** Grease every four (4) months. Change grease every twelve (12) months.
3. **MEAT CARRIAGE BEARINGS:** Grease every four (4) weeks.
4. **SAW GUIDE BAR:** Oil daily with food machine oil.
5. **MEAT GAUGE GEAR RACK:** Oil daily with food machine oil.
6. **BLADE TENSION SPRING SCREW ASSEMBLY:** Grease every 4 weeks –
NOTE: Remove upper wheel and turn #14782 Blade Tension screw clockwise until it bottoms out against #14781 Blade Tension Handle then fill the cavity under the O-Ring on the #14782 Blade Tension Screw with #374 Shell Cassida Grease EPS-2 and re-assemble.

USE BIRO No. 374 GREASE FOR RE-GREASING
SEE INSTRUCTIONS BELOW

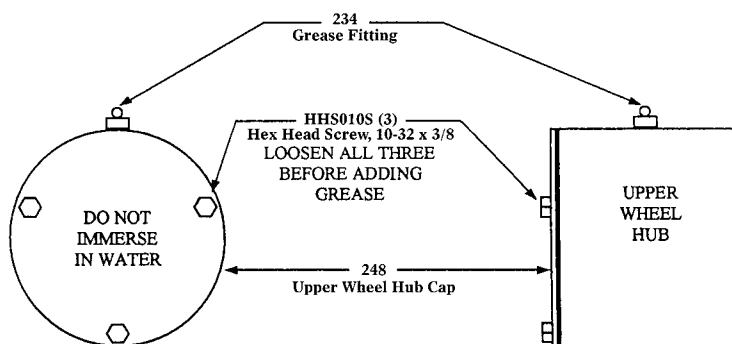

When lubricating the upper wheel bearing it is important that the three hex head screws securing the upper wheel hub cap be loosened slightly before attempting to pump grease into the grease fitting. Loosening the screws allows for an escape of old broken down grease and air from the bearing cavity. Failure to loosen the screws before greasing the upper bearings can cause the upper shaft seal to be dislodged from the upper wheel allowing grease to escape and moisture to get into the cavity. When finished greasing the bearings, retighten the three screws. Take care to also clean off any grease that was pushed out of the cavity during greasing.

7. **MOTOR BEARINGS:** Bearing grease will lose its lubricating ability over time, not suddenly. The lubricating ability of a grease (over time) depends primarily on the type of grease, the size of the bearing, the speed at which the bearing operates and the severity of the operating conditions. Good results can be obtained if the following recommendations are used in your maintenance program.

A high grade ball or roller bearing grease should be used. Recommended grease for standard service conditions is Polyrex EM (Exxon Mobil).

Equivalent and compatible greases include: Texaco Polystar, Rykon Premium #2, Pennzoil Pen 2 Lube, and Chevron SRI.

Recommended lubrications intervals is every 9 months with the equivalent of two (2) teaspoons of grease.

OPERATOR'S NOTES

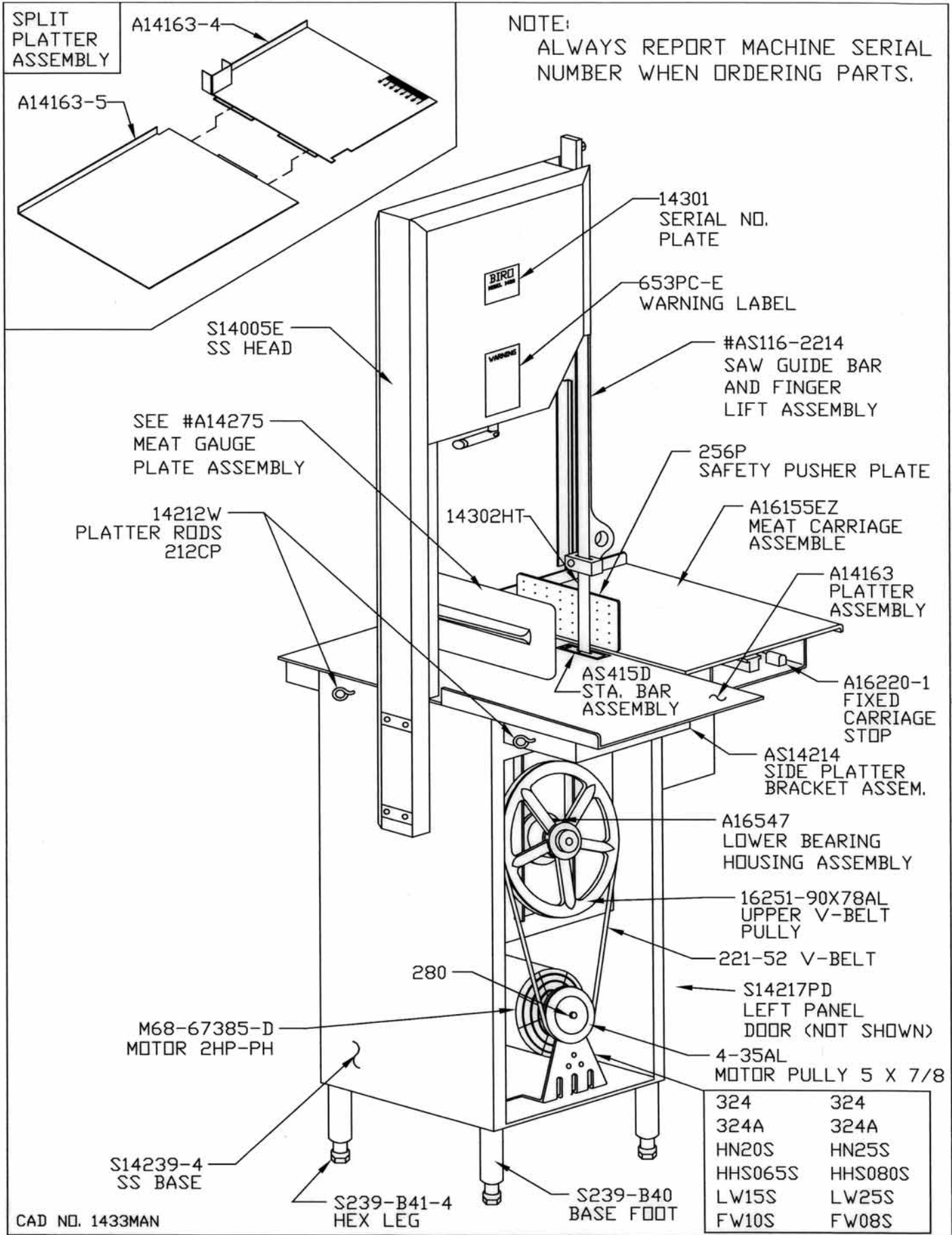

UPDATED 5-27-09

NOTE:
ALWAYS REPORT MACHINE SERIAL
NUMBER WHEN ORDERING PARTS

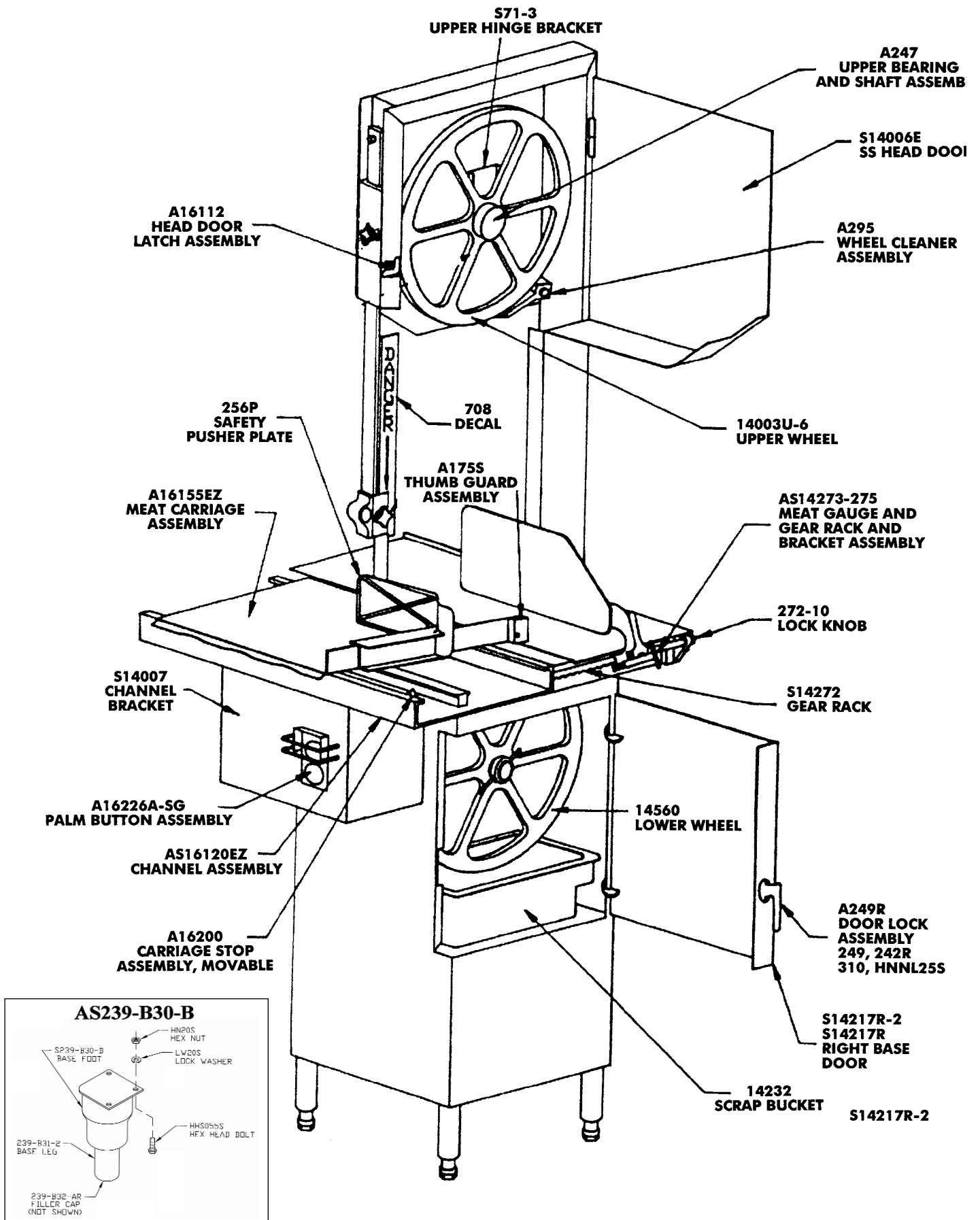

**MODEL 1433
FIXED HEAD &
DOOR ASSEMBLY, S.S.**

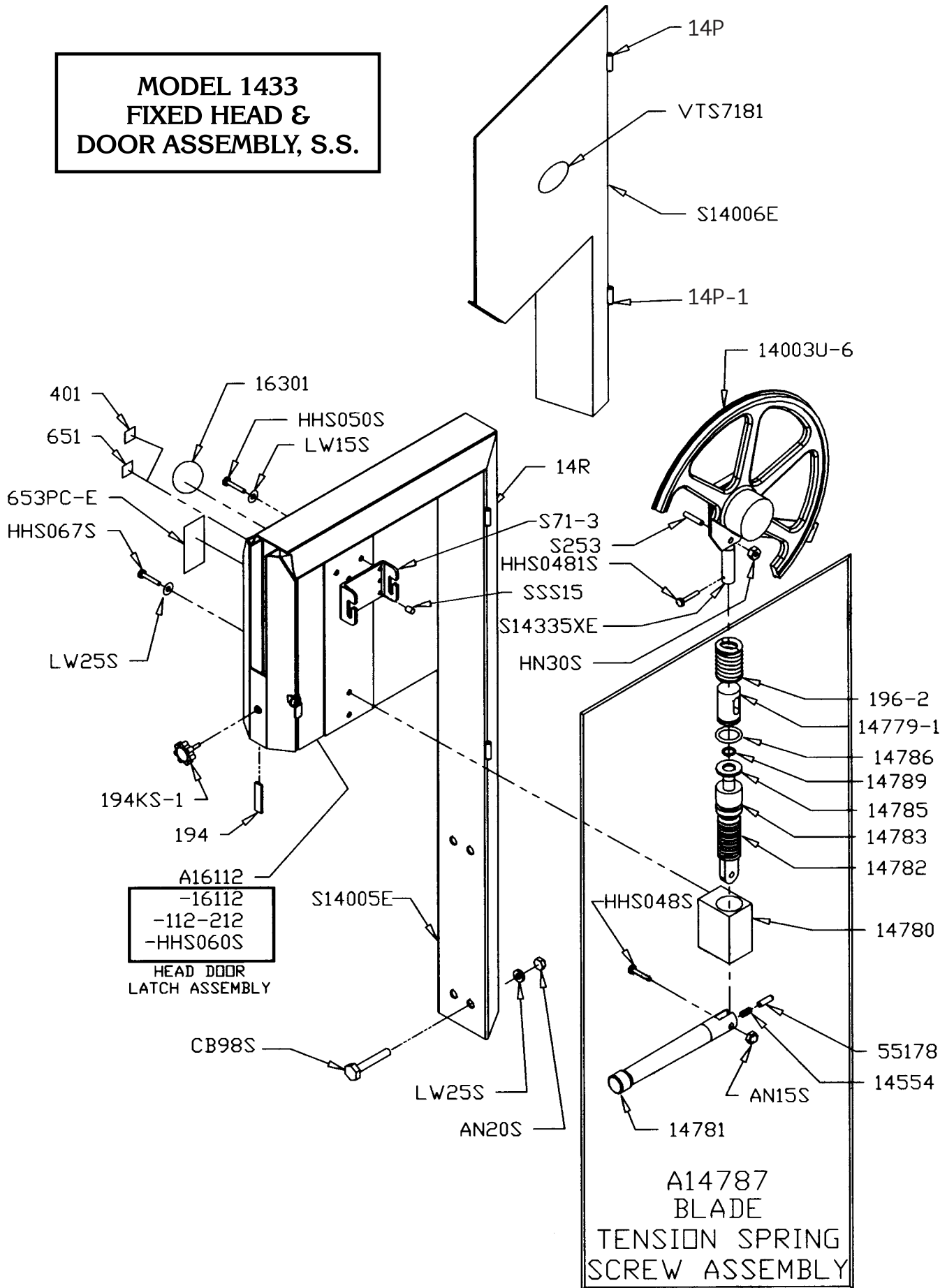

ITEM No.: 14782K Blade Tension Screw Conversion Kit

INSTALLATION INSTRUCTIONS

Disconnect the machine from main power supply.

Loosen tension on the saw blade and remove the upper wheel assembly

Unbolt the (A) tensioning handle from the (B) blade tension screw.

At the bottom handle mount turn the (B) blade tension screw clockwise until it can be lifted out of the (C) housing.

Apply a good food grade grease to the replacement (D) tension screw and install into the (C) housing turning counterclockwise until it bottoms out.

Replace the (A) tensioning handle. Be sure the (E) spring and (F) plunger pin are still present in the end of the (A) handle.

Replace the upper wheel assembly and the blade.

Tension the blade.

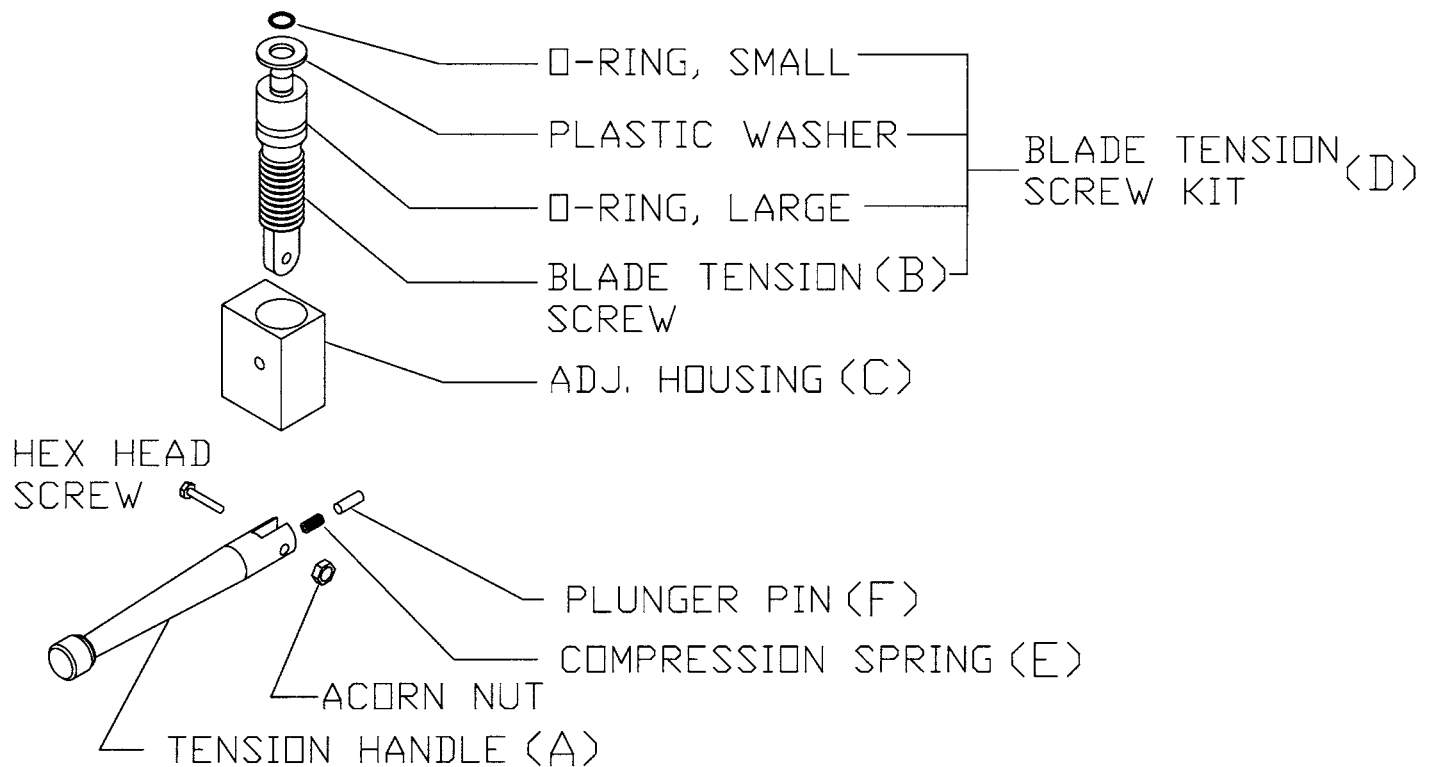

(A) 14781	Tension Handle	14783	O-Ring, Large
(B) 14782	Blade Tension Screw	14785	Plastic Washer
(C) 14780	Adjustment Housing	14789	O-Ring, Small
(D) 14782K	Blade Tension Screw Kit	AN15S	Acorn Nut, 1/4-20
(E) 14554	Compression Spring	HHS048S	Hex Head Screw 1/4-20 x 1 1/4
(F) 55178	Plunger Pin		

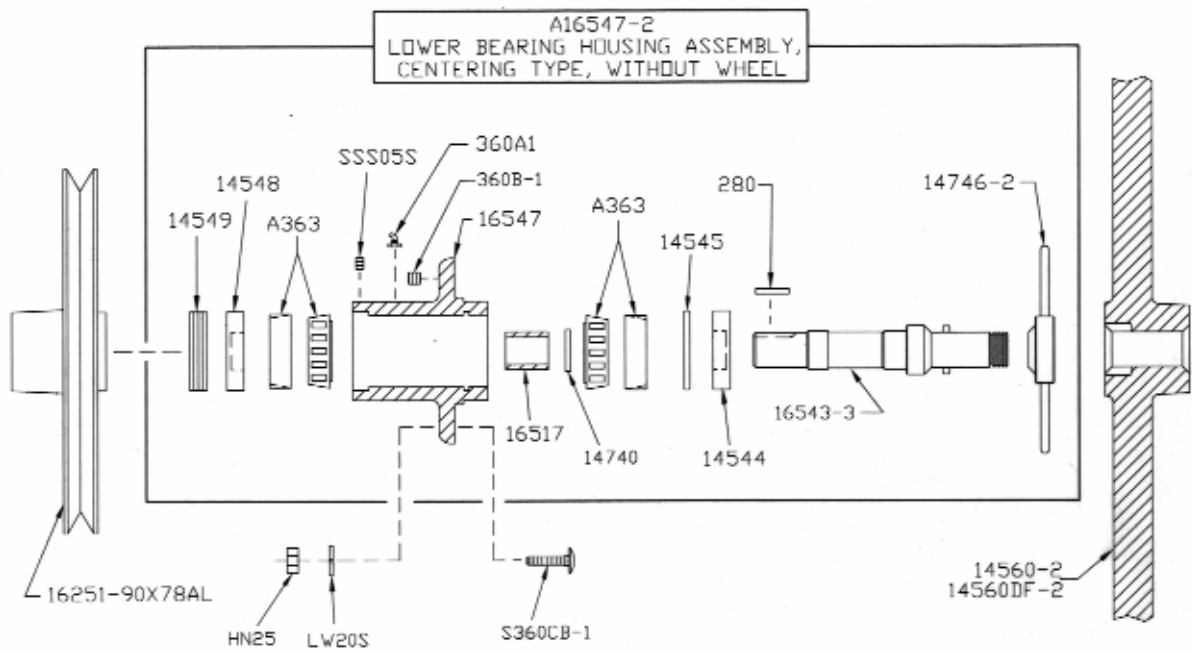

Item No.	Description
A16547-2	Lower bearing housing assembly w/o wheel
A363	Lower bearing cup/cone assembly
HN35S	Hex nut, 3/8-16, SS
LW20S	Lock washer, 3/8, SS
SSS05S	Set screw cup, SS, 10-24 x 3/8
14544	Grease seal, 1.50 ID
14545	Retaining ring, internal, 2 3/16 ID
14548	Grease seal, 3/8 ID
14549	Lower bearing housing cap
14550	Adjustment screw, lower bearing housing
14551	Hex jam nut, 3/8-11, SS

Item No.	Description
14560-2	Lower saw wheel, 14"
14560DF-2	Lower saw wheel 14", double flange
14740	Retaining ring - external
14746-2	T-handle lock, removable lower wheel
16251-90X78AL	Pulley, upper V-belt 9.0 x 3/8 AL
16517	Inner race spacer, removable wheel
16543-3	Shaft, lower saw wheel
16547	Lower bearing housing, removable wheel
280	Key
360A1	Grease fitting angular
360B-1	Set screw 1/2-13

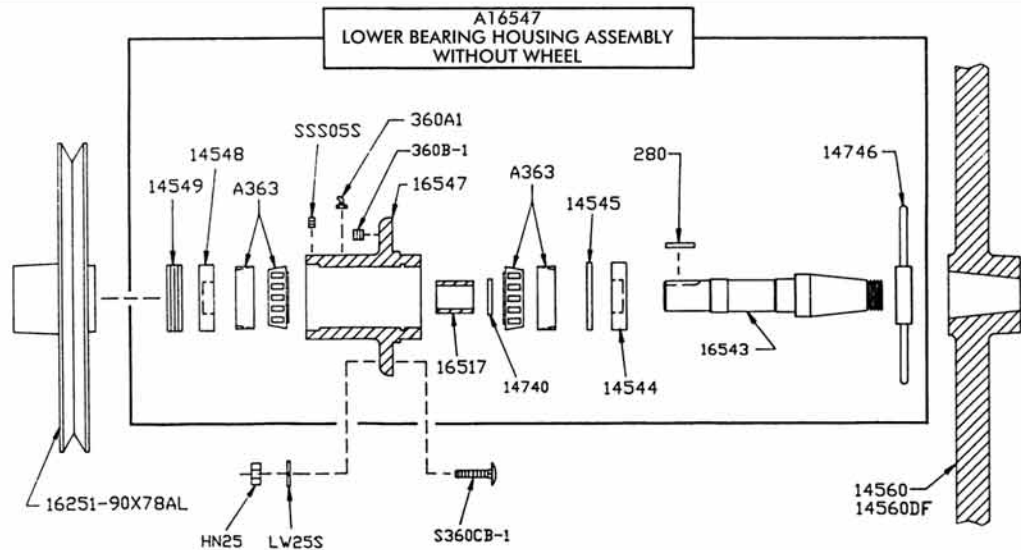

Item No.	Description
A16547	Lower bearing housing assembly w/o wheel
A363	Lower bearing cup/cone assembly
HN35S	Hex nut, 3/8-16, SS
LW20S	Lock washer, 3/8, SS
SSS05S	Set screw cup, SS, 10-24 x 3/8
14544	Grease seal, 1.50 ID
14545	Retaining ring, internal, 2 3/16 ID
14548	Grease seal, 3/8 ID
14549	Lower bearing housing cap
14550	Adjustment screw, lower bearing housing
14551	Hex jam nut, 3/8-11, SS

Item No.	Description
14560	Lower saw wheel, 14"
14560DF	Lower saw wheel 14", double flange
14740	Retaining ring - external
14746	T-handle lock, removable lower wheel
16251-90X78AL	Pulley, upper V-belt 9.0 x 3/8 AL
16517	Inner race spacer, removable wheel
16543	Shaft, lower saw wheel
16547	Lower bearing housing, removable wheel
280	Key
360A1	Grease fitting angular
360B-1	Set screw 1/2-13

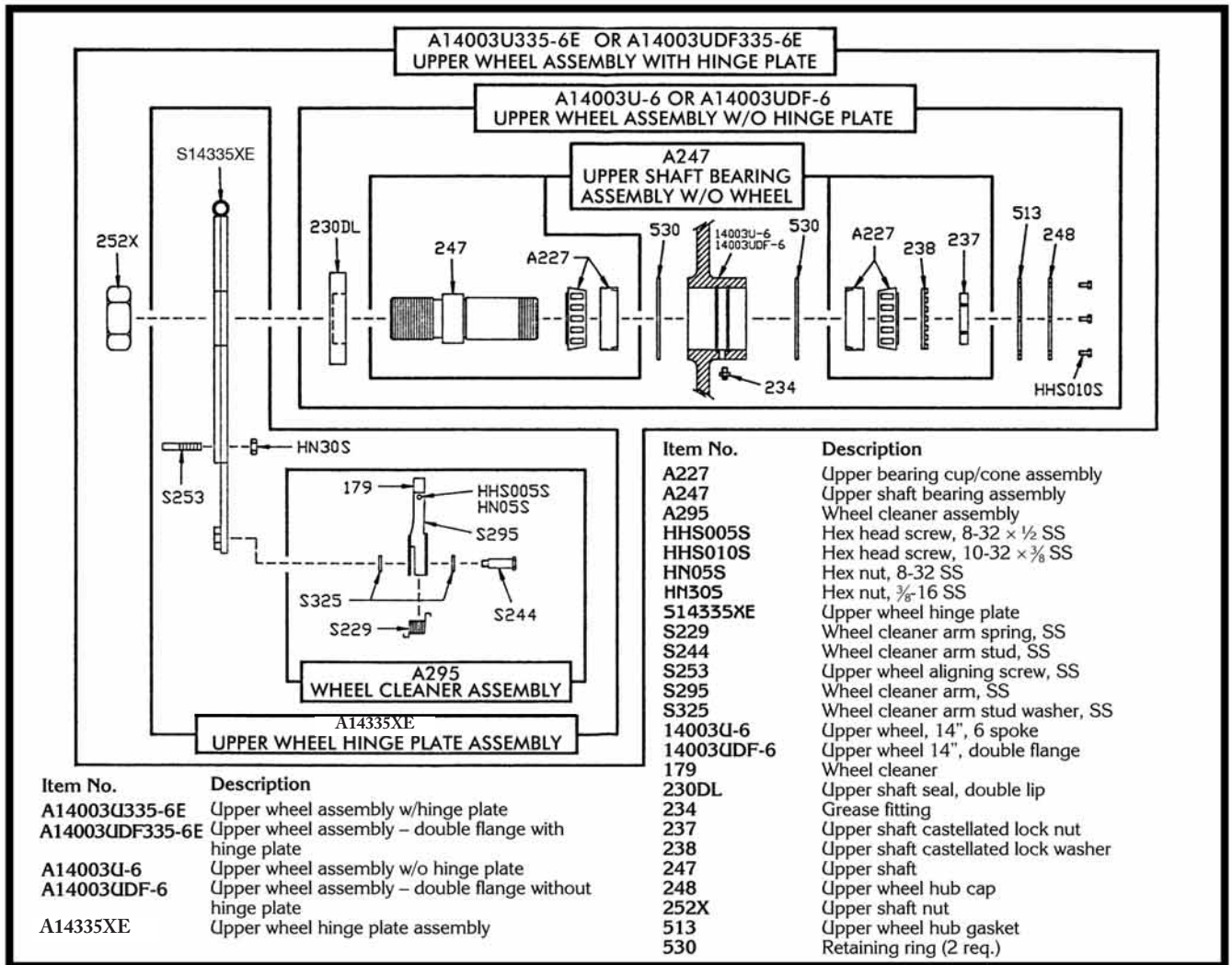

The Base Door Hinge System on the Model 1433 and 1433FH Series has been changed from an internal "plate & pin" system to an external "barrel and pin" system (see sketch below).

Old Style

Hinged Base Door - #S14217R
Before Serial No. 2218

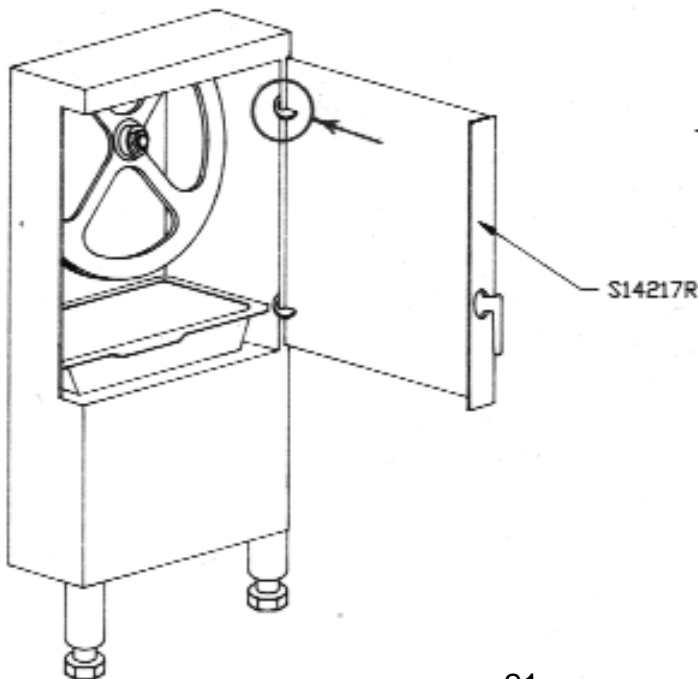

New Style

Hinged Base Door - #S14217R-2
Starting with Serial No. 2218

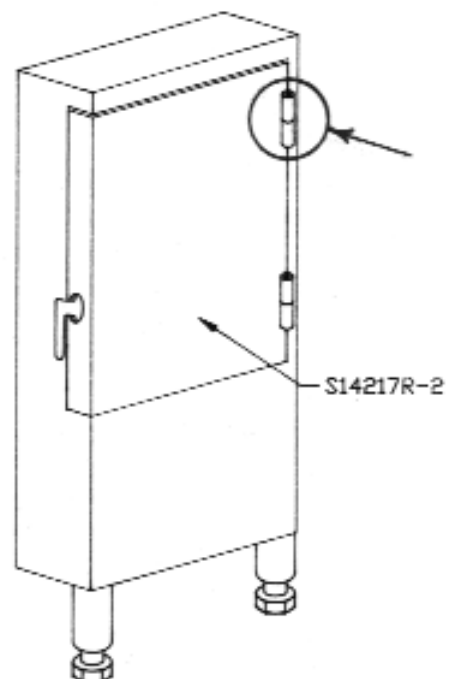

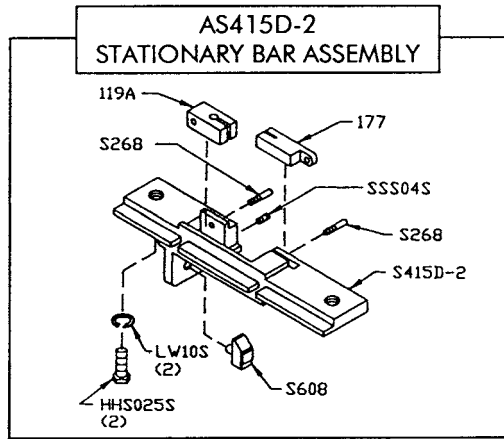

Item No.	Description
AS415D-2	Stationary bar assembly
HHS025S	Hex head screw, 1/4-20 x 1/2 SS
LW10S	Lock washer, 1/4 SS
S268	Stationary bar headless screw
119A	Saw guide in stationary bar
177	Nylon filler
S415D-2	Stationary bar
S608	Back-up guide, carbide
SSS04S	Set screw, 10-24 x 1/4 SS, cup point

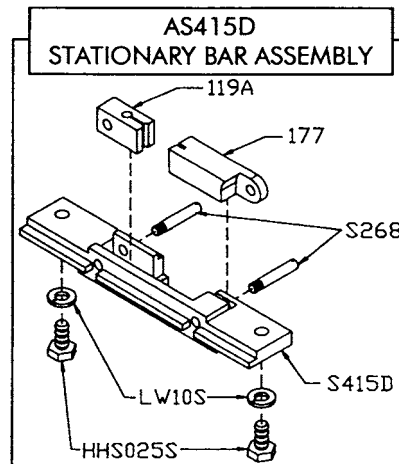

Item No.	Description
AS415D	Stationary bar assembly
HHS025S	Hex head screw, 1/4-20 x 1/2 SS
LW10S	Lock washer, 1/4 SS
S268	Stationary bar headless screw
119A	Saw guide in stationary bar
177	Nylon filler
S415D	Stationary bar

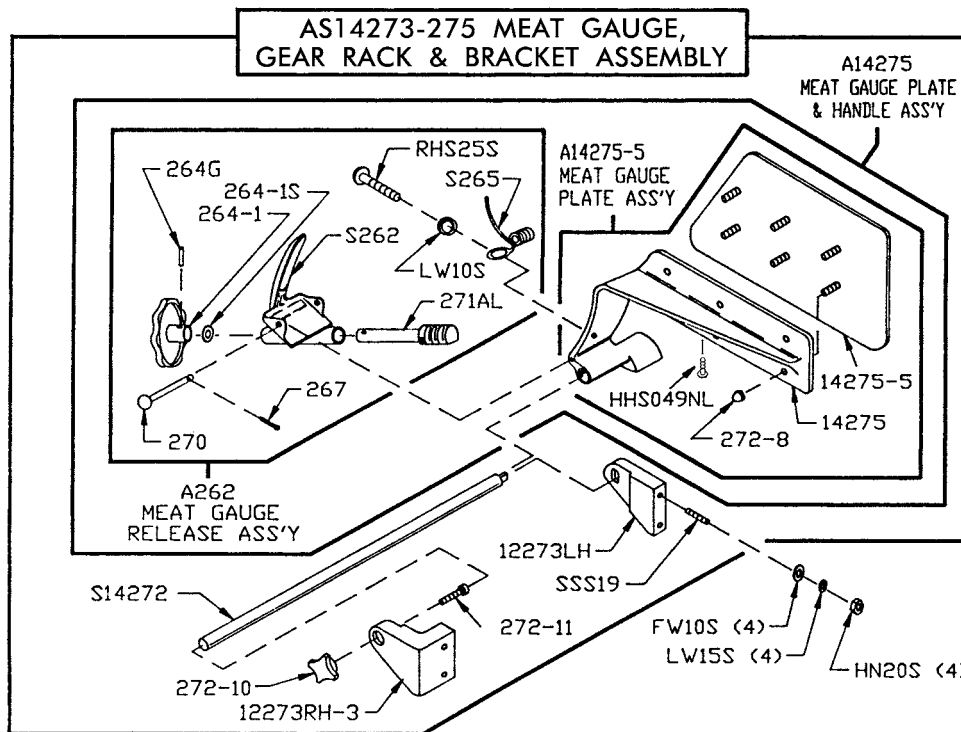

Item No.	Description
AS14273-275	Meat gauge assembly
A14275	Meat gauge plate assembly
A262	Meat gauge release assembly
FW10S	Flat washer, 5/16 SS
HHS049NL	Hex screw - nylon 5/16-18 x 1/2 lg.
HN20S	Hex nut, 5/16-18 SS
LW10S	Lock washer, 1/4 SS
LW15S	Lock washer, 5/16 SS
RHS25S	Round head screw, 1/4-20 x 3/4 SS
SSS19	Set screw, cup point, 5/16-18 x 1 1/2, SS
S235	Taper pin, 4 x 3/4 SS
S262	Meat gauge release handle, SS
S265	Meat gauge release spring, SS
S14272	Meat gauge gear rack, SS

Item No.	Description
12273LH	Meat gauge brkt. - LH
12273RH-3	Meat gauge brkt. - RH
14275	Meat gauge arm
14275-5	Meat gauge plate, SS
264G	Meat gauge hand wheel groove pin
264-1	Meat gauge hand wheel
264-1S	Hand wheel shim
267	Meat gauge release cotter key
270	Meat gauge release pin
271AL	Meat gauge worm gear, Aluminum
272-8	Cap nut, 5/16-18 SS
272-10	Lock knob 5/8-16, 4 point
272-11	Allen head cap screw 5/8-16 x 1 1/2 lg.

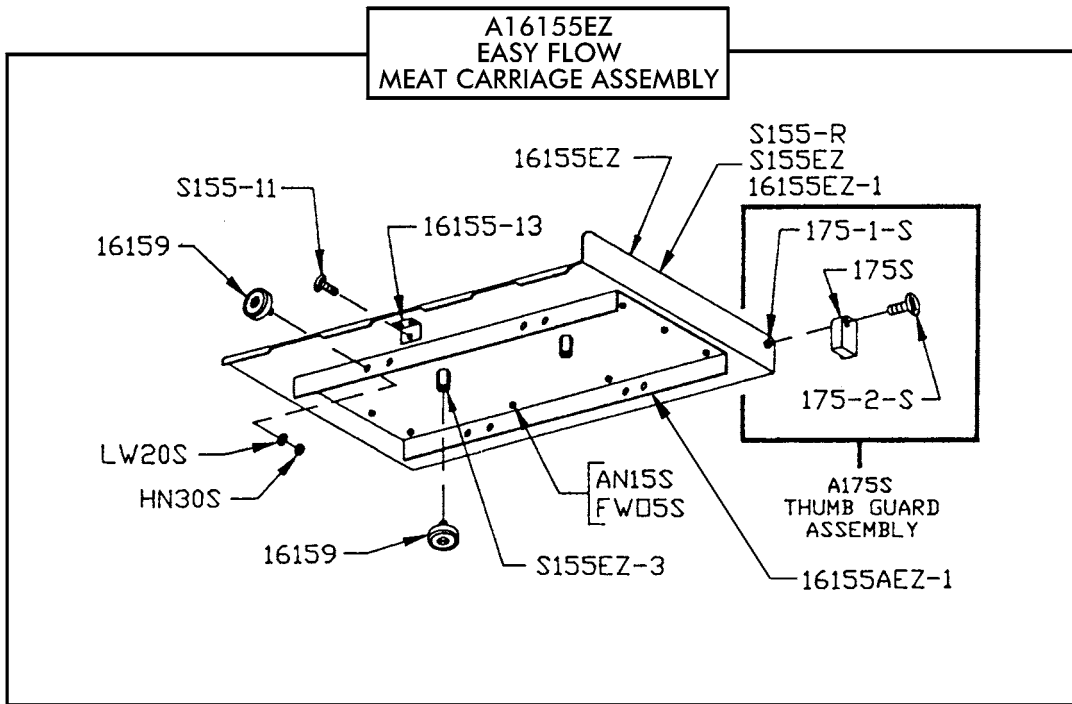

Item No.	Description	Item No.	Description
A16155EZ	Meat carriage assembly complete – EZ Flow	S155EZ-3	Hex standoff, easy flow carriage
A175S	Thumb guard assembly	16155EZ	Meat carriage top & angle only
FW05S	Flat washer, ¼ SS	16155EZ-1	Meat carriage top only w/weld studs (DNS)
AN15S	Acorn nut, ¼-20, SS	16155-13	Carriage stop angle SS
HN30S	Hex nut, ⅜-16 light jam SS	16155AEZ-1	Meat carriage angle plate
LW20S	Lock washer, ⅜ regular SS	16159	Meat carriage bearing SS
S155-11	Meat carriage stop thumb screw	175S	Thumb guard, nylon
S155-R	Raw meat carriage top only (DNS)	175-1-S	Thumb guard nut, SS
S155EZ	Meat carriage top only (NSS)	175-2-S	Thumb screw, ¼-20 × ½, SS

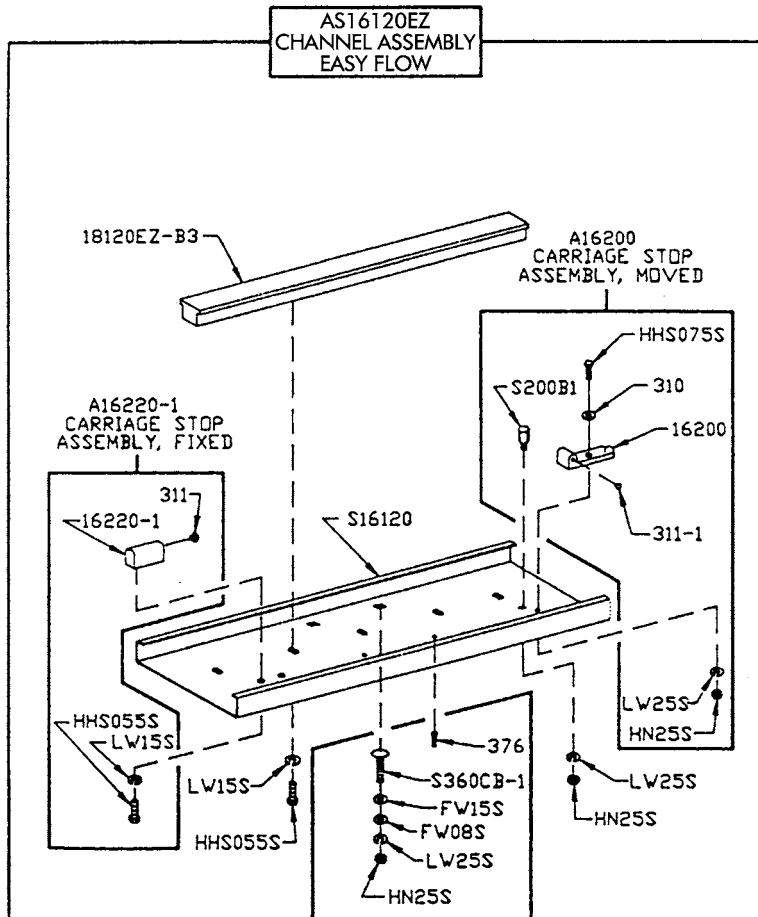

Item No.	Description
A16200	Channel stop assembly, movable
A16220-1	Channel stop assembly, fixed
AS16120EZ	Channel assembly with center guide
FW08S	Flat washer, ⅜, SS
FW15S	Flat washer, ½, SS
HHS055S	Hex head screw, ⅜-18 × ¾ SS
HHS075S	Hex head screw, ⅜-16 × 1¼ SS
HN25S	Hex nut, ⅜-16, SS
LW15S	Lock washer, ⅜, SS
LW25S	Lock washer, ⅜, SS
S16120	Channel, SS
S200B1	Stop stud, carriage stop, SS
S360CB-1	Carriage bolt, ⅜-16 × 1¼ SS
16200	Carriage stop, movable w/#311-1
16220-1	Carriage stop, fixed w/#311
18120EZ-B3	Guide bar, EZ flow, T-shaped
310	Waved washer, movable carriage stop
311	Rubber bumper for #16220-1 stop
311-1	Rubber bumper for #16200 stop
376	Drive screw, #10 × ½ lg., SS

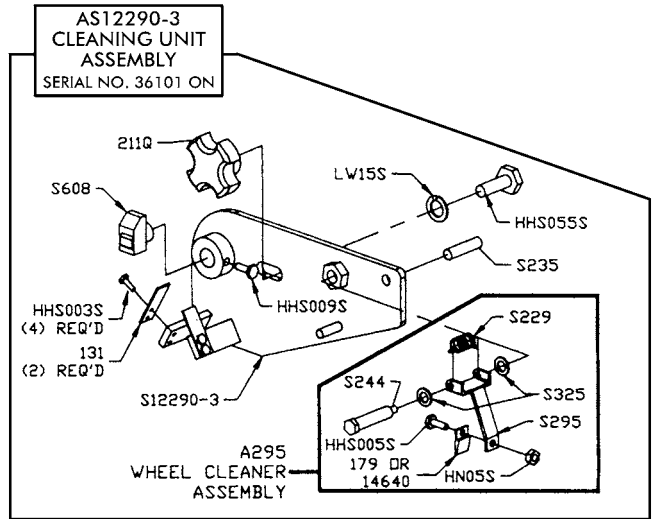
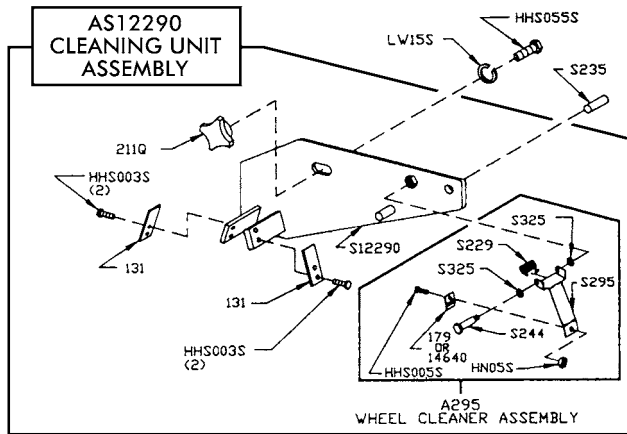

Item No.	Description
AS12290	Cleaning unit assembly
AS12290-3	Cleaning unit assembly
A295	Wheel cleaner assembly
HHS003S	Hex head screw, 8-32 x 1/4 trimmed SS
HHS005S	Hex head screw, 8-32 x 1/2 SS
HHS009S	Hex head screw, 10-24 x 1/4 SS
HHS055S	Hex head screw, 5/16-18 x 3/4 SS
HN05S	Hex nut, 8-32 SS
LW15S	Lock washer, 5/16 SS
S12290	Cleaning unit
S12290-3	Cleaning unit
S229	Wheel cleaner arm spring, SS

Item No.	Description
S235	Taper pin, #4 x 3/4 SS
S244	Wheel cleaner arm stud, SS
S295	Wheel cleaner arm, SS
S325	Wheel cleaner arm stud washer, SS
S608	Saw back-up guide w/607 carbide
131	Blade cleaner, SS
131N	Blade cleaner, nyleen
131SHORT	Blade cleaner, SHORT SS, 1 1/16 LG
131SS/NYL	Blade cleaner combo, short, SS, STD Nyleen
179	Wheel cleaner
211Q	Lock knob, 5/16-18, 4 point
14640	Wheel cleaner, Rulon

Item No.	Description
AS116-2214	Saw guide bar assembly 22"
A14211	Finger lift assembly, removable
A602	Saw guide assembly, upper
FW05S	Flat washer, 1/4, SS
HHS015S	Hex head screw, 10-32 x 7/8 SS
HHS020S	Hex head screw, 1/4-20 x 3/8 SS
HHS083S	Hex head screw, 3/8-16 x 1 3/4 SS
HN10S	Hex nut, 10-32 SS
LW05S	Lock washer, #10 SS
LW10S	Lock washer, 1/4 SS
RHS10S	Round head screw, 10-32 x 3/4 SS
RHS30S	Round head screw, 1/4-20 x 3/8 SS
S200B1	Stop stud on guide bar
S116-22	Saw guide bar, 22" SS
14255	Saw guard
17211-22	Finger lift shim, .022
17211-35	Finger lift shim, .035
193	Saw guide bar spring
211	Finger lift bracket
211A-291Q	Fastener knob, 4 point
601	Upper saw guide bracket
602B	Upper saw guide with carbide
602AFSC	Upper saw guide, narrow, fish
708	Decal "DANGER EXPOSED BLADE"

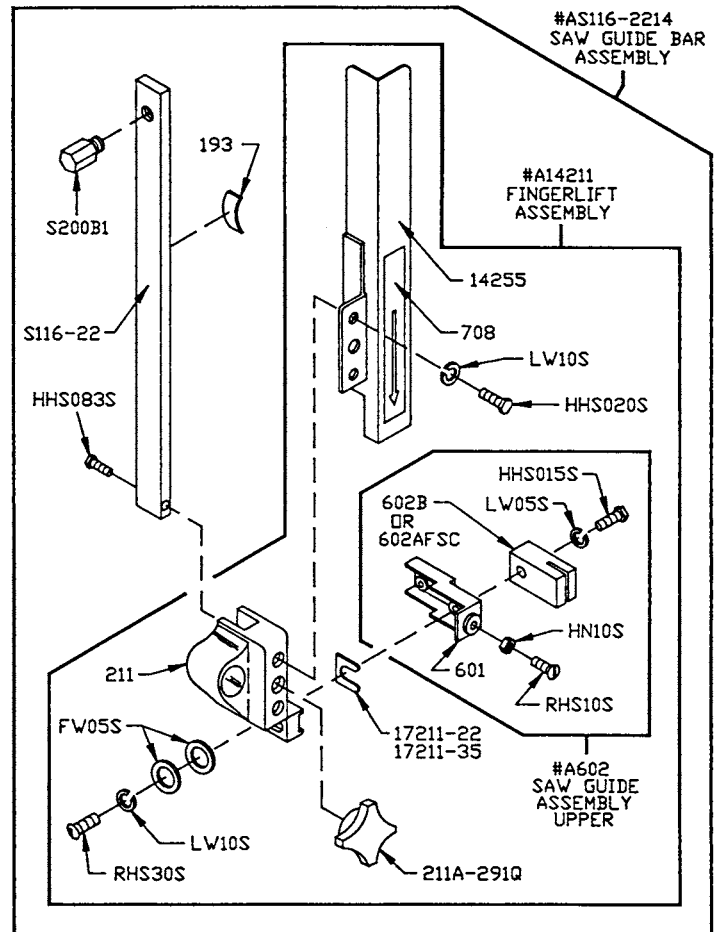

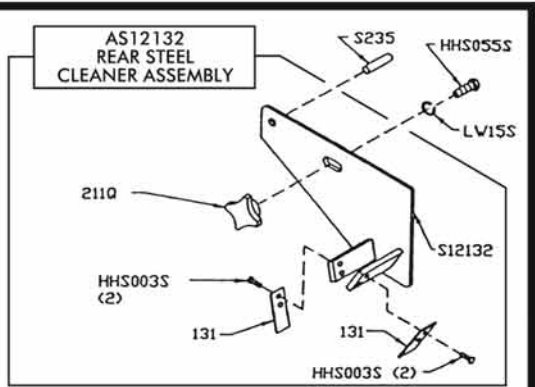

Item No.	Description
AS12132	Steel cleaner assembly, rear
HHS003S	Hex head screw, 8-32 x 1/4 SS
HHS055S	Hex head screw, 3/16-18 x 3/4 SS
LW15S	Lock washer, 5/16 SS
S12132	Cleaning unit, rear
S235	Taper pin, #4 x 3/4 SS
131	Blade cleaner, SS
211Q	Lock knob, 3/8-18, 4 point

WATERTIGHT MAGNETIC SWITCH ASSEMBLIES (AEG) INCLUDES MOUNTING BRACKET AND WIRES

Item No.	Description
A22616EE-514	BAEG/MS-PB/05-C8 2HP 208-220-50/60-3
A22616EE-516	BAEG/MS-PB/05-E4.7 2HP 440/460-3
A22616EE-518	BAEG/MS-PB/05-D4.7 1.5HP-2HP 380/415-50-3
A22616EE-522	BAEG/MS-PB/05-C14 3HP 220-230-50/60-3
A22616EE-5221	BAEG/MS-PB/05-CS14 1.5HP 220/230-50/60-1
A22616EE-5241	BAEG/MS-PB/A26 1.5HP-2HP 104/115/60-1
A22616EE-5261	BAEG/MS-PB/CS16 2HP 230-60-1
A22616EE-530	BAEG/MS-PB/05-F3.2 2HP 550/575-3
A22616EE-534	BAEG/MS-PB/05-E6.3 3HP 440/460-60-3
A22616EE-536	BAEG/MS-PB/05-D8 3HP 380-60-3

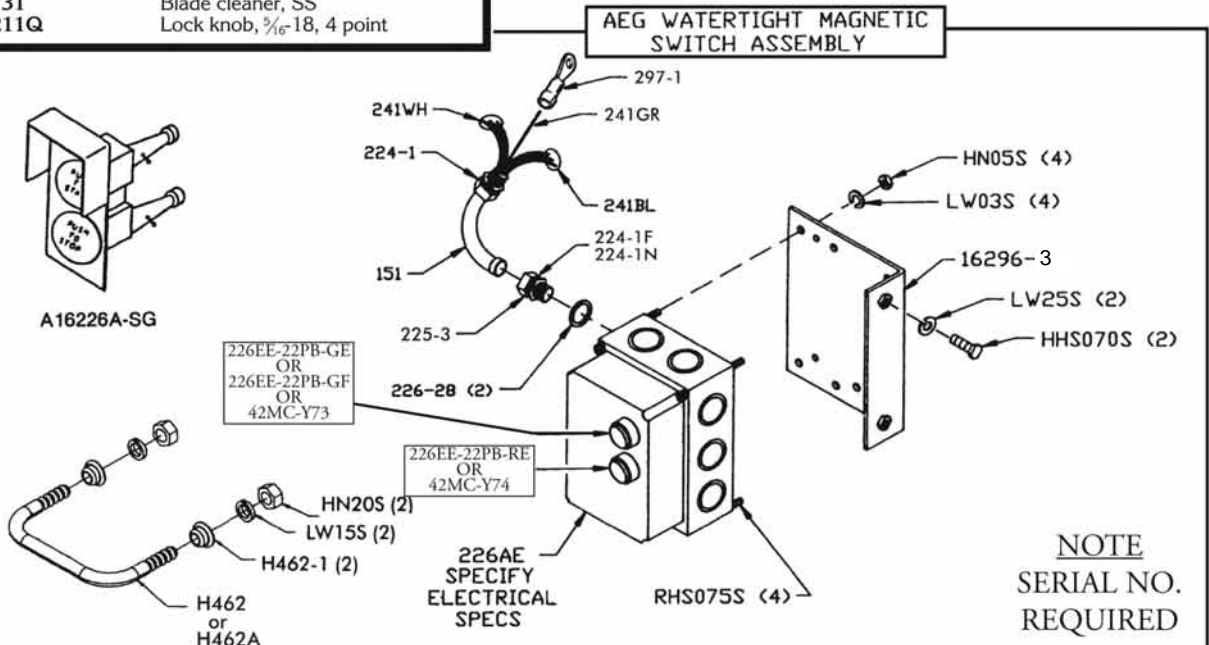

NOTE
SERIAL NO.
REQUIRED

Item No.	Description
A16226A-SG	Green/red switch button assembly
H462A	Guard assembly for switch buttons
H462	Guard for switch buttons
H462-1	Trim ferrule - SS
HHS070S	Hex head screw, 3/8-16 x 1 SS
HN05S	Hex nut, 8-32 SS
HN20S	Hex nut 5/16-18 SS
LW03S	Lock washer, #8 SS
LW15S	Lock washer 5/16 SS
LW25S	Lock washer, 3/8 heavy SS
RHS075S	Round head screw, 8-32 x 3/4 SS
14256	Junction box, plastic w/cover
14257	Junction box, metal
14258	Junction box cover, metal
16296-2	Switch bracket SS
151	Watertight conduit
225-3	Conduit connector, WT, 45°
226EE-ENCL-PB30	ENCLOSURE WITH PUSHBUTTON 30MM HOLES
226EE-OL02.4H	OVERLOAD B05-H, 1.7-2.4A
226EE-OL41	OVERLOAD B18K-1, 2.5-4A
H281EE-51	OVERLOAD B18K-K, 4-6.3 A
226EE-OL08.5L	OVERLOAD B 18K-L, 5.5-8.5A

Item No.	Description
226EE-OL12M	OVERLOAD B18K-M, 8-12A
H281EE-31	OVERLOAD B18K-N, 10-16A
226EE-OL26ON	OVERLOAD B18K-ON, 21-26A
226EE-AO11K	CONTACTOR, LS11K.11S-AO, 120V
226EE-CO11K	CONTACTOR, LS11K.11S-CO, 208-230V
226EE-EO11K	CONTACTOR, LS11K.11S-CO 480V, 60HZ-380V 50HZ
226EE-FO11K	CONTACTOR, LS11K.11S-FO, 575V
226EE-22PB-GE	START P/B, 22MM EXT W/NO CONTACT BLK
226EE-22PB-GF	START P/B, 22MM FLUSH W/NO CONTACT BLK
226EE-22PB-RE	STOP P/B, 22 MM EXT W/NC CONTACT BLOCK
226EE-514	BAEG/MS-PB/05-C8 2HP 220-50/60-3
226EE-516F	BAEG/MS-PBF/05-E 4.7 1-1/2, 2HP 440-60-3
226EE-518	BAEG/MS-PB/05-D4.7 2HP-380-50-3
226EE-5221	BAEG/MS-PSF/05-CS14 1.5HP 230-50/60-1
226EE-5241	BAEG/MS-PB/A26 2HP 120-60-1
226EE-5261	BEAG/MS-PB/CS16 2HP 230-60-1
226EE-530	BAEG/MS-PB/05-F3.2 2HP 550-60-3
226EE-534	BAEG/MS-PB/05-E6.3 3HP 440-60-3
226EE-536	BAEG/MS-PB/05-D8 3HP 380-50-3
226-28	WASHER, 1-1/2 X 27/32 SS
241BL	WIRE, BLACK, 12 GA., CSA & UL
241 GR	WIRE, GREEN, 12 GA., CSA & UL
241 RD	WIRE, RED, 12 GA., CSA & UL
241 WH	WIRE, WHITE, 12 GA., CSA & UL
42MC-Y73	GREEN START BUTTON
42MC-Y74	RED STOP BUTTON

- OPERATOR'S NOTES -

**115 VOLT WITH 6 LEADS -
 SCHEMATIC USING 1 PH AEG LS11K CONTRACTOR / B18K OVERLOAD
 W.T. SWITCH FOR 115 VOLT, SINGLE PHASE, 60 CYCLE WEG MOTOR 1-1/2HP WITH
 -6 MOTOR LEADS**

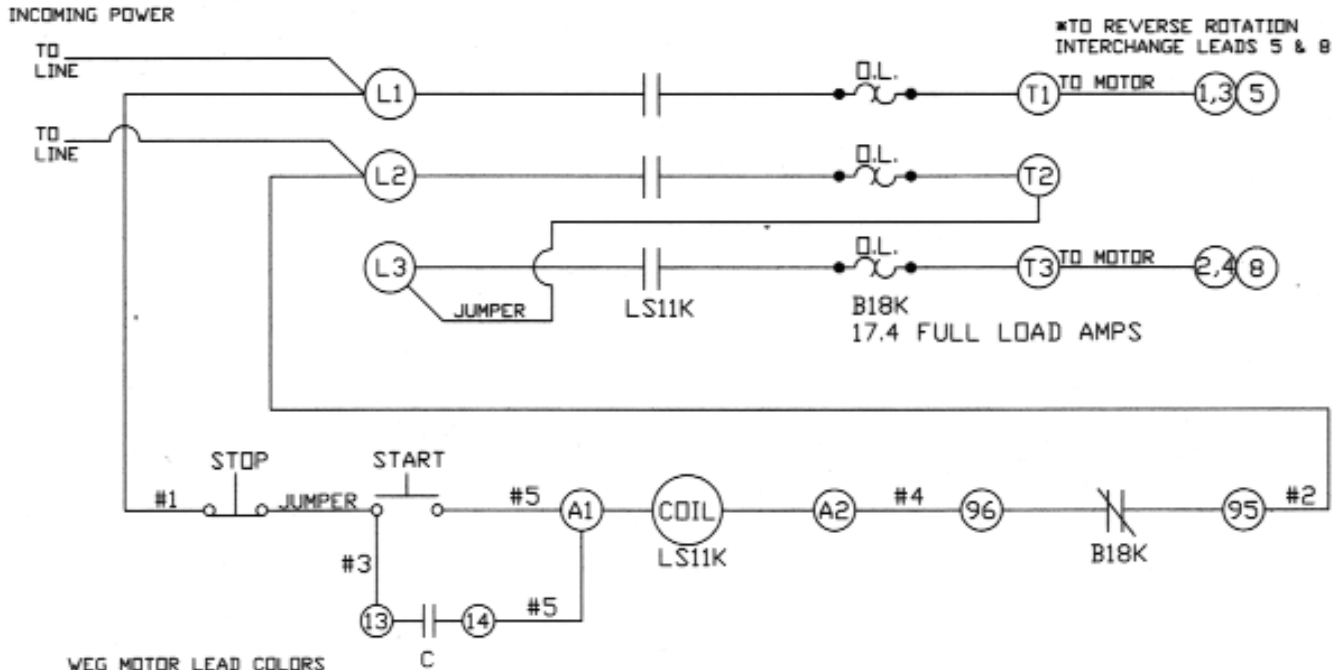

- WEG MOTOR LEAD COLORS**
- #1 BLUE
 - #2 WHITE
 - #3 DRANGE
 - #4 YELLOW
 - #5 BLACK
 - #8 RED

1-1/2HP WEG MOTOR - M40-158ES1BF56W

**208/230 VOLT WITH 6 LEADS -
 SCHEMATIC USING 1 PH AEG LS05 CONTRACTOR / B05 OVERLOAD
 W.T. SWITCH FOR 208-230 VOLT, SINGLE PHASE, 60 CYCLE WEG MOTOR 1-1/2HP WITH
 -6 MOTOR LEADS**

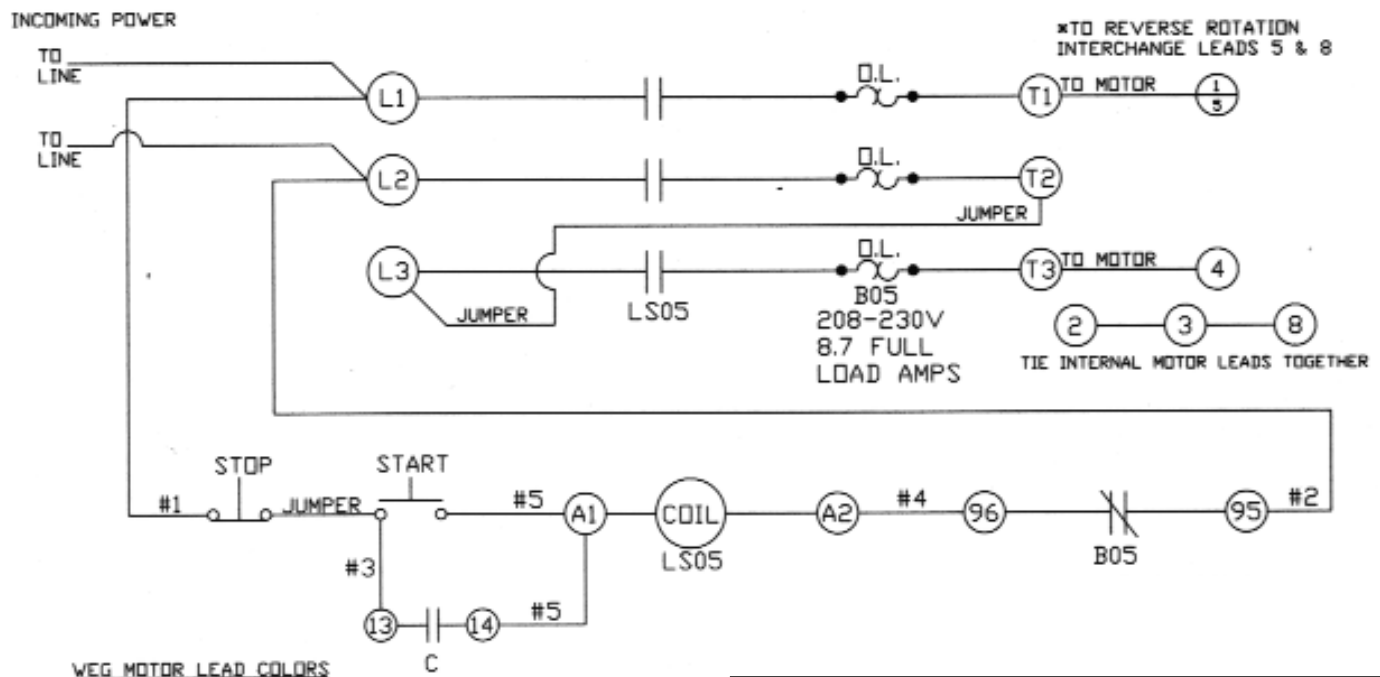

- WEG MOTOR LEAD COLORS**
- #1 BLUE
 - #2 WHITE
 - #3 DRANGE
 - #4 YELLOW
 - #5 BLACK
 - #8 RED

1-1/2HP WEG MOTOR - M40-158ES1BF56W

-115 VOLT WITH 7 LEADS-

SCHEMATIC USING 3-POLE AEG WATERTIGHT SWITCH WITH JUMPER TO ELIMINATE BREAKING EFFECT OF MOTOR AFTER STOP IS ENGAGED. 2HP/60HZ/1PH BALDOR MOTOR WITH 7 MOTOR LEADS, WIRED FOR 115 VOLTS

115V/60HZ/1PH
INCOMING POWER

*TO REVERSE ROTATION
INTERCHANGE LEADS 5 & 8

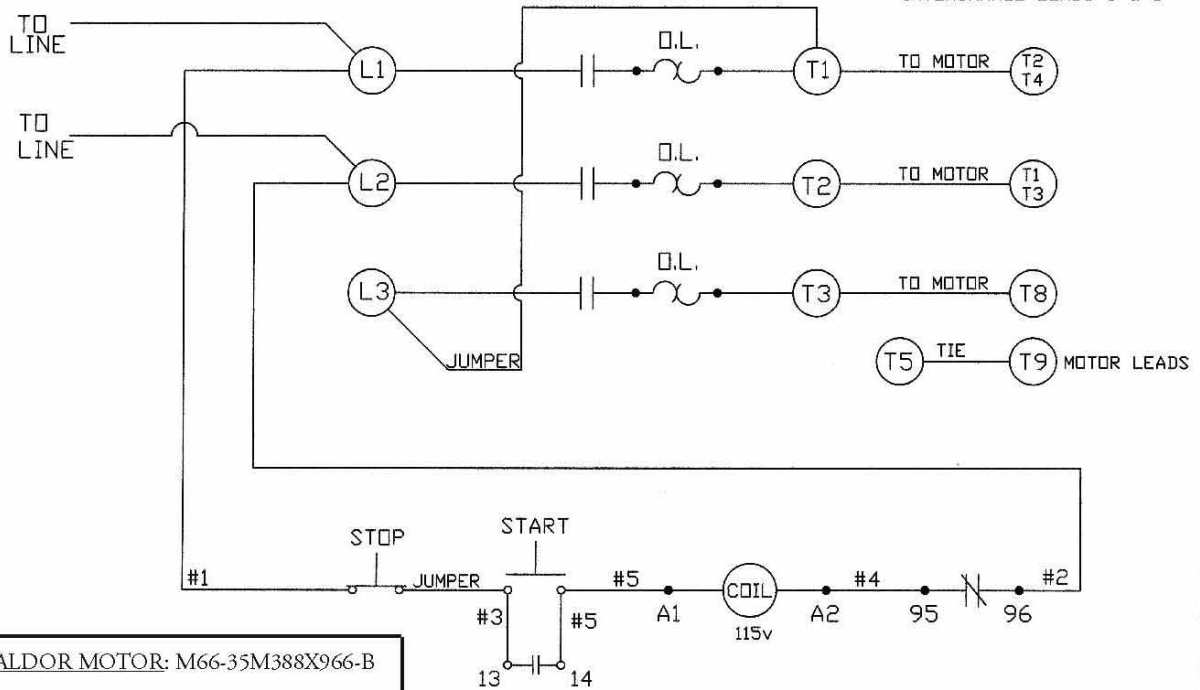

2HP BALDOR MOTOR: M66-35M388X966-B

-230 VOLT WITH 4 LEADS-

SCHEMATIC USING 3-POLE AEG WATERTIGHT SWITCH WITH JUMPER TO ELIMINATE BREAKING EFFECT OF MOTOR AFTER STOP IS ENGAGED. 2HP/50HZ/1PH BALDOR MOTOR WITH 4 MOTOR LEADS, WIRED FOR 230 VOLTS

230V/50HZ/1PH
INCOMING POWER

*TO REVERSE ROTATION
INTERCHANGE LEADS 5 & 8

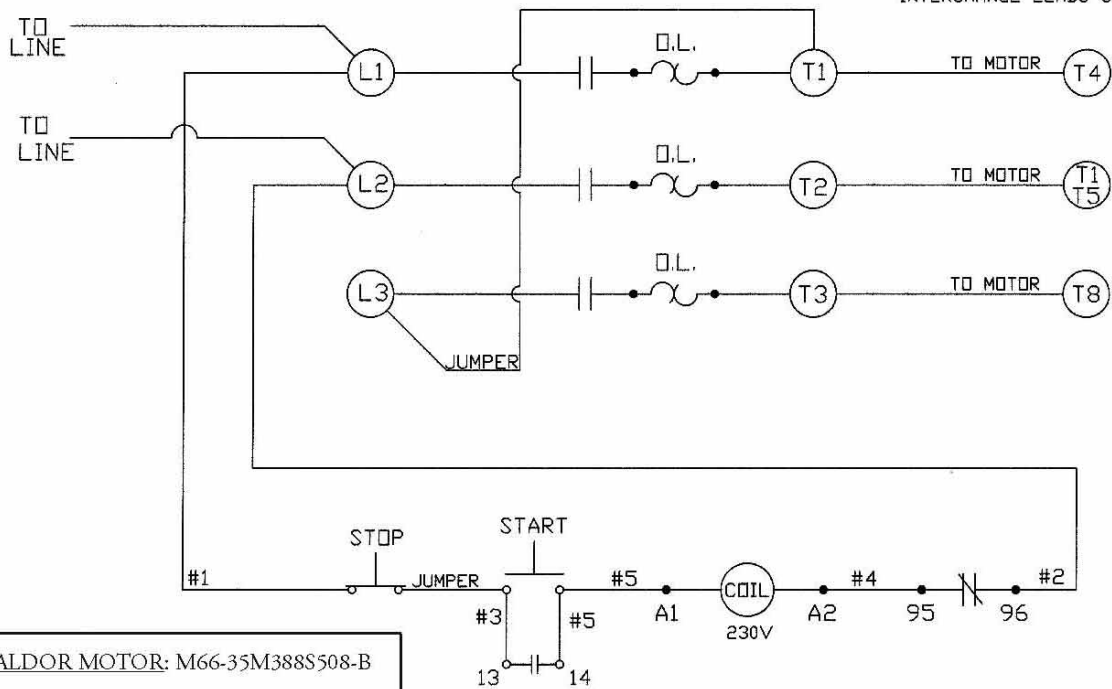

2HP BALDOR MOTOR: M66-35M388S508-B

-230 VOLT WITH 7 LEADS-

SCHEMATIC USING 3-POLE AEG WATERTIGHT SWITCH WITH JUMPER TO ELIMINATE BREAKING EFFECT OF MOTOR AFTER STOP IS ENGAGED. 2HP/60HZ/1PH BALDOR MOTOR WITH 7 MOTOR LEADS, WIRED FOR 230 VOLTS

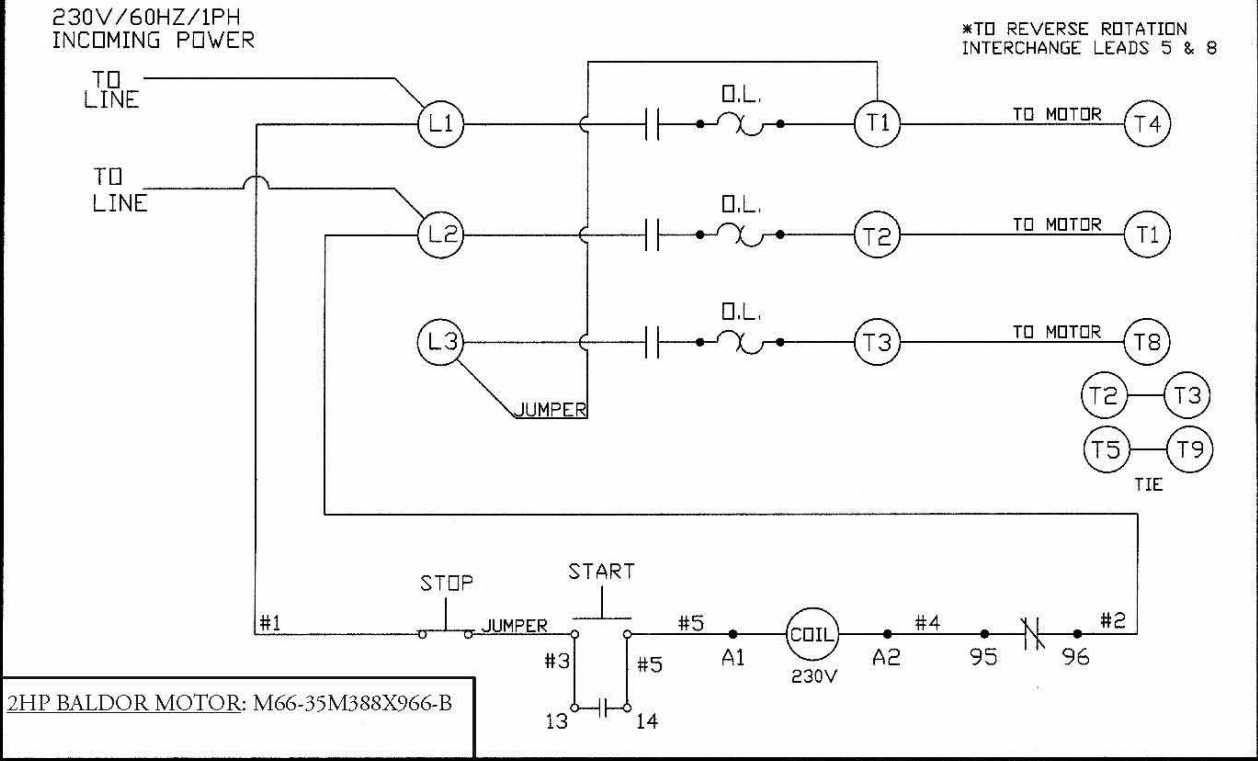

-208/230 VOLT WITH 9 LEADS-

SCHEMATIC USING 3-POLE AEG W.T. SWITCH 2HP/50/60HZ/3PH WEG MOTOR WITH 9 MOTOR LEADS WIRED FOR 208/230 VOLTS

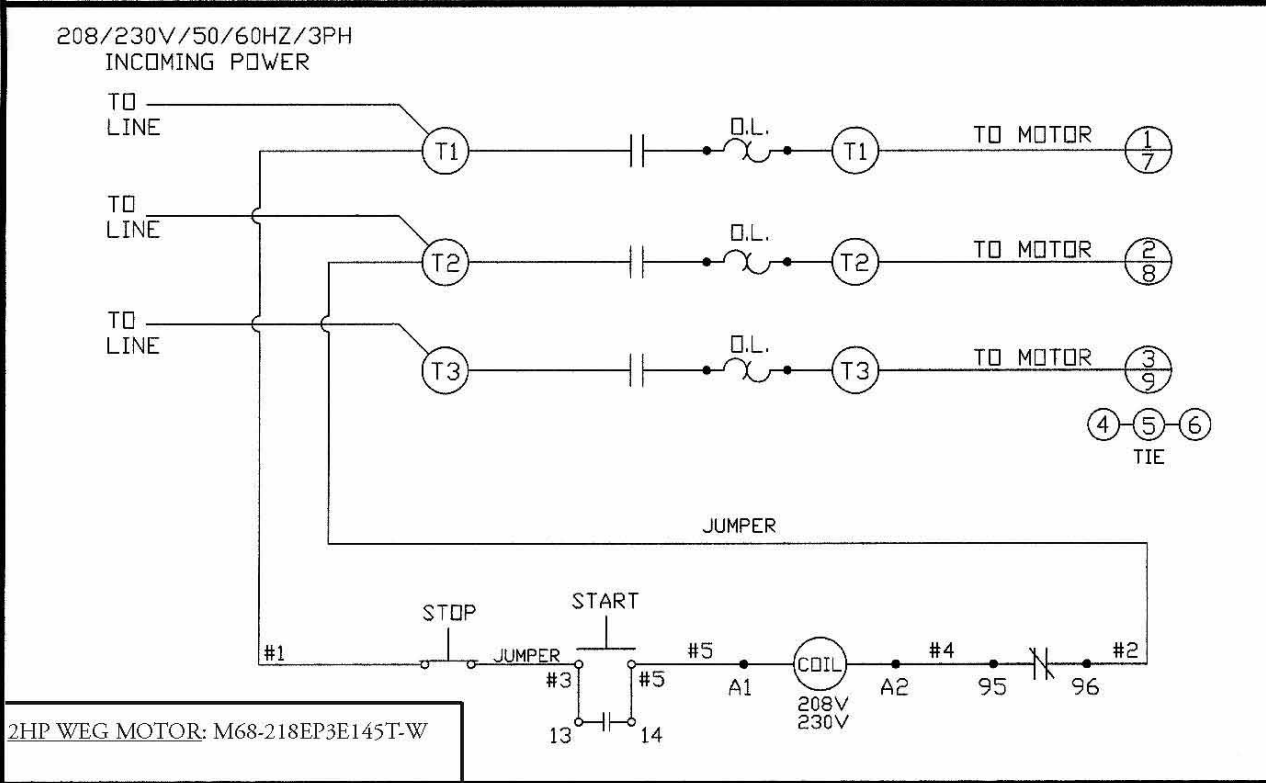

-208/220/230 VOLT 3 PHASE WITH 9 LEADS-

SCHEMATIC USING 3-POLE STROMBERG OR AEG W.T. SWITCH
 2HP/60HZ/3PH BALDOR MOTOR WITH 9 MOTOR LEADS (OR)
 2HP & 3HP/50/60HZ/3PH US ELECTRIC/EMERSON MOTOR WITH 9 MOTOR LEADS
 WIRED FOR 208/220/230 VOLTS

208/220/230V/60HZ/3PH
 INCOMING POWER

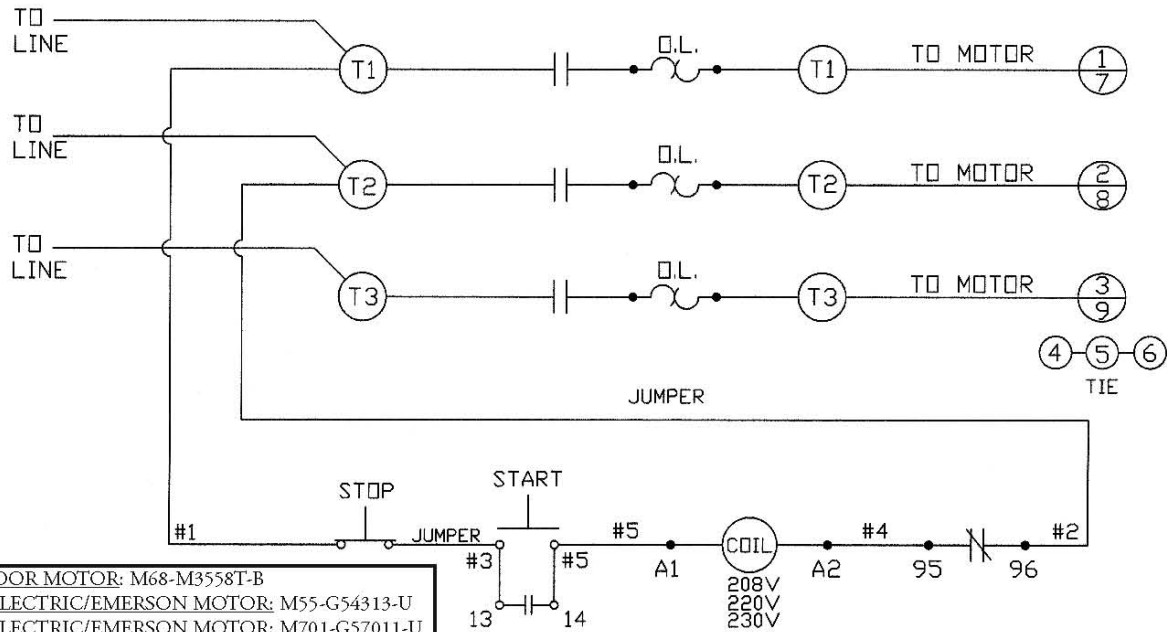

2HP BALDOR MOTOR: M68-M3558T-B
 2HP US ELECTRIC/EMERSON MOTOR: M55-G54313-U
 3HP US ELECTRIC/EMERSON MOTOR: M701-G57011-U

-220 VOLT 3 PHASE WITH 12 LEADS-

SCHEMATIC USING 3-POLE STROMBERG OR AEG W.T. SWITCH
 2HP/50HZ/3PH BALDOR MOTOR WITH 12 MOTOR LEADS WIRED FOR 220 VOLTS

220V/50HZ/3PH
 INCOMING POWER

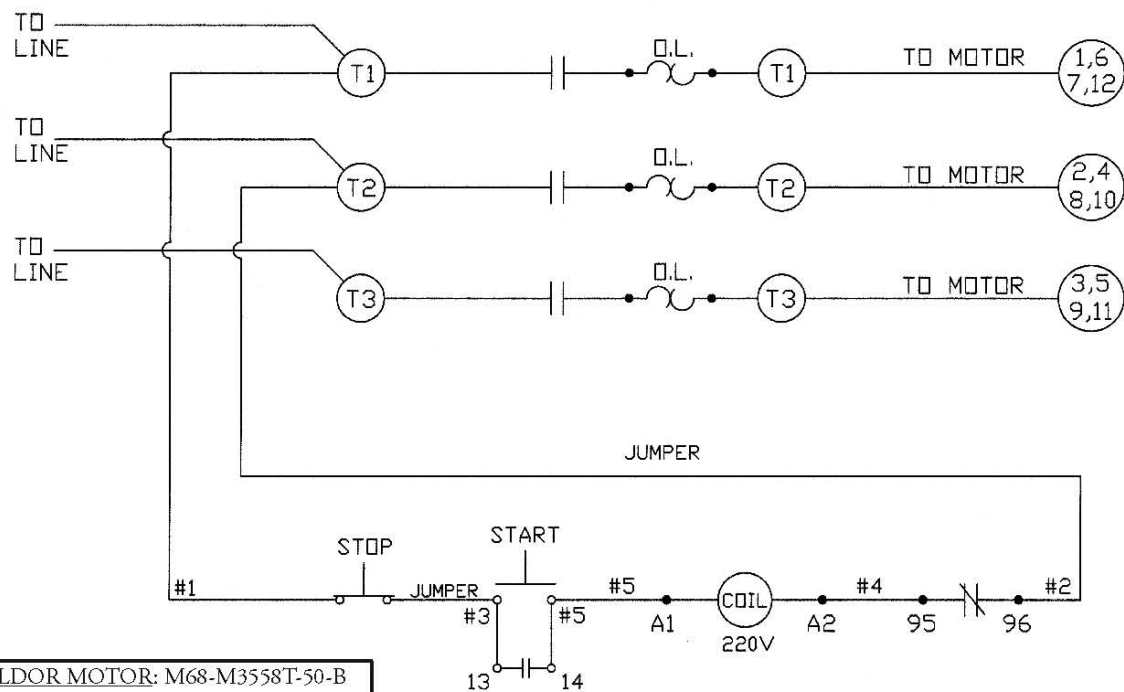

2HP BALDOR MOTOR: M68-M3558T-50-B

-380/460 VOLT WITH 9 LEADS

SCHEMATIC USING 3-POLE AEG W.T. SWITCH
 2HP/50/60HZ/3PH WEG MOTOR WITH 9 MOTOR LEADS WIRED FOR 380/460 VOLTS

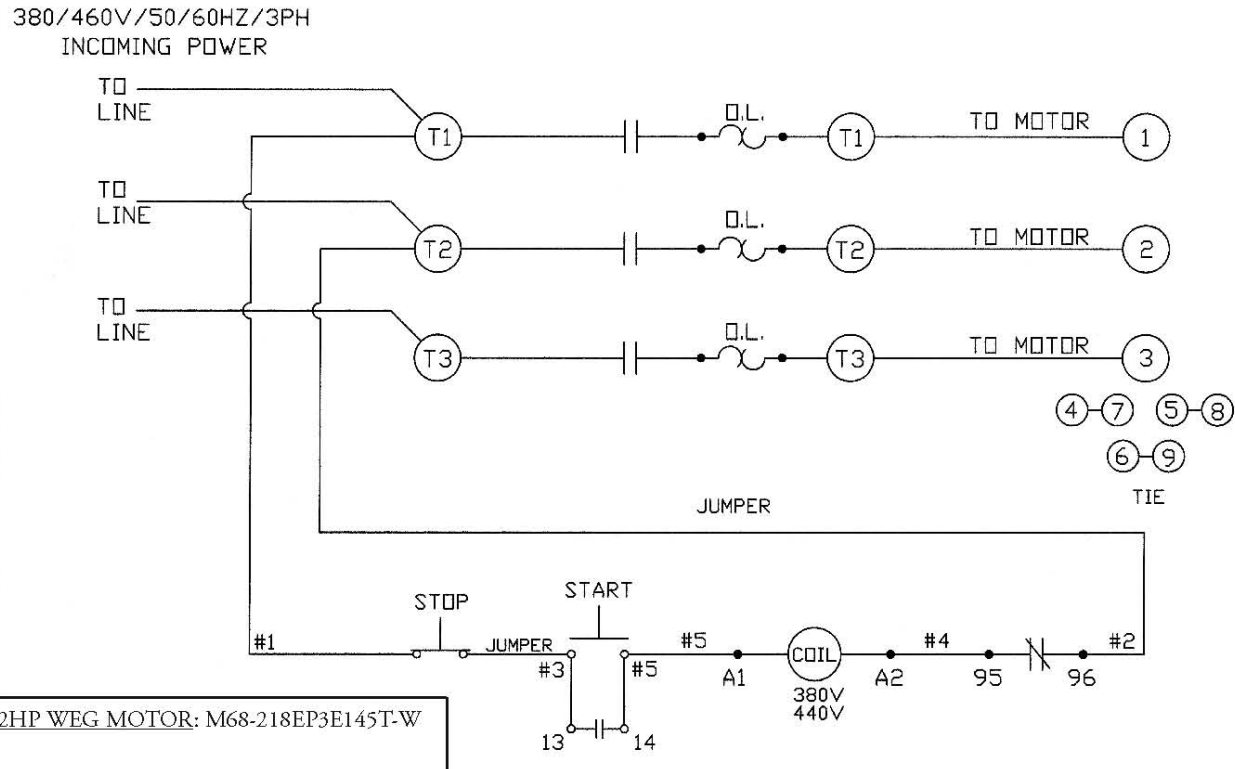

-380 VOLT, 3 PHASE WITH 12 LEADS-

SCHEMATIC USING 3-POLE STROMBERG OR AEG W.T. SWITCH
 2HP/50HZ/3PH BALDOR MOTOR WITH 12 MOTOR LEADS WIRED FOR 380 VOLTS

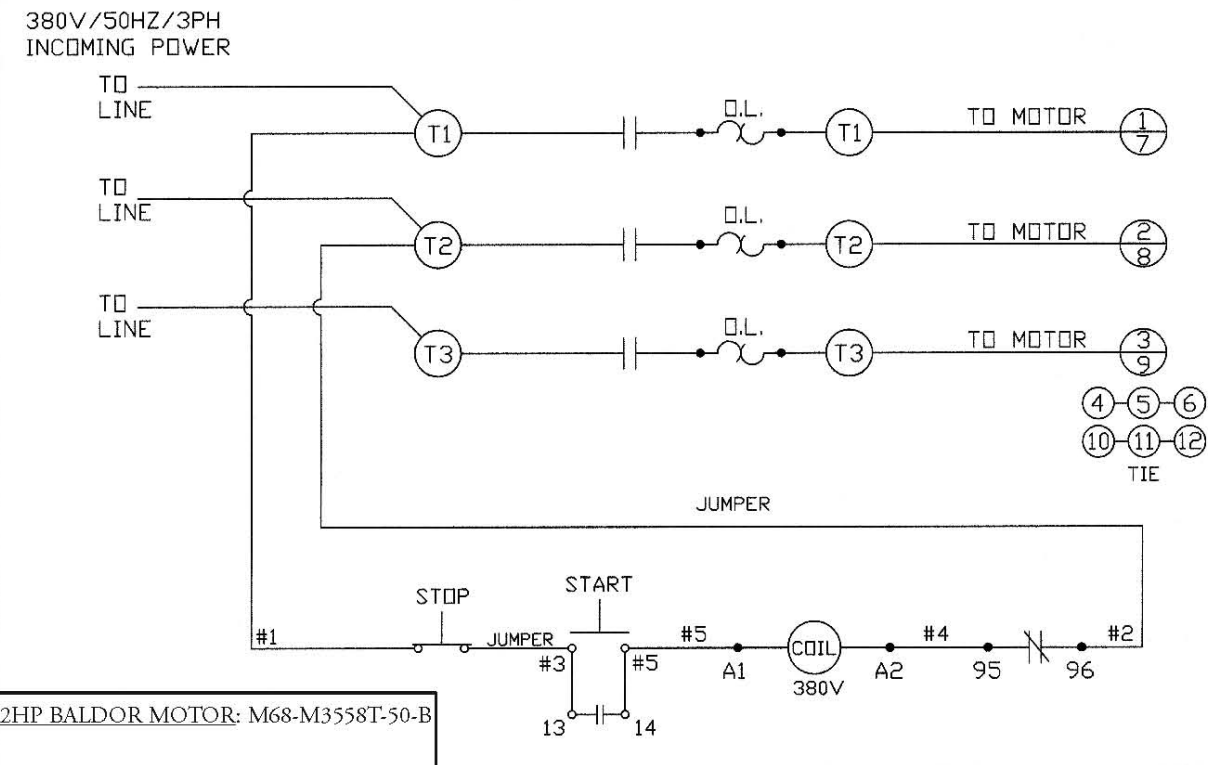

-440/460 VOLT 3 PHASE WITH 9 LEADS-

SCHEMATIC USING 3-POLE STROMBERG OR AEG W.T. SWITCH
 2HP/60HZ/3PH BALDOR MOTOR WITH 9 MOTOR LEADS (OR)
 2HP & 3HP/50/60HZ/3PH US ELECTRIC/EMERSON MOTOR WITH 9 MOTOR LEADS
 WIRED FOR 440/460 VOLTS

440/460V/50/60HZ/3PH
 INCOMING POWER

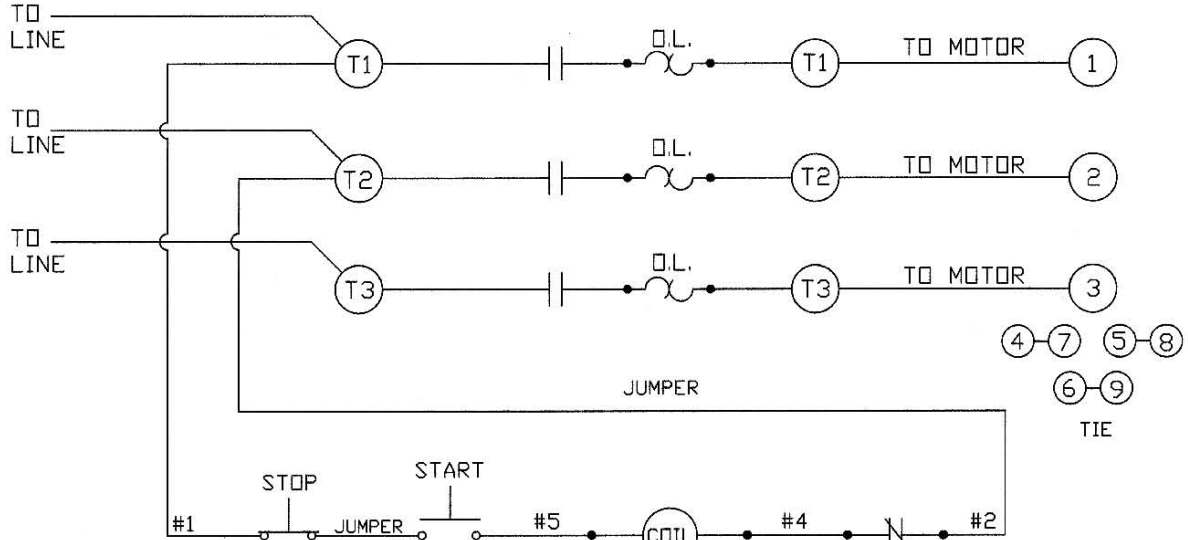

2HP BALDOR MOTOR: M68-M3558T-B
 2HP US ELECTRIC/EMERSON MOTOR: M55-G54313-U
 3HP US ELECTRIC/EMERSON MOTOR: M701-G57011-U

-440 VOLT, 3 PHASE WITH 12 LEADS-

SCHEMATIC USING 3-POLE STROMBERG OR AEG W.T. SWITCH
 2HP/50HZ/3PH BALDOR MOTOR WITH 12 MOTOR LEADS WIRED FOR 440 VOLTS

440V/50HZ/3PH
 INCOMING POWER

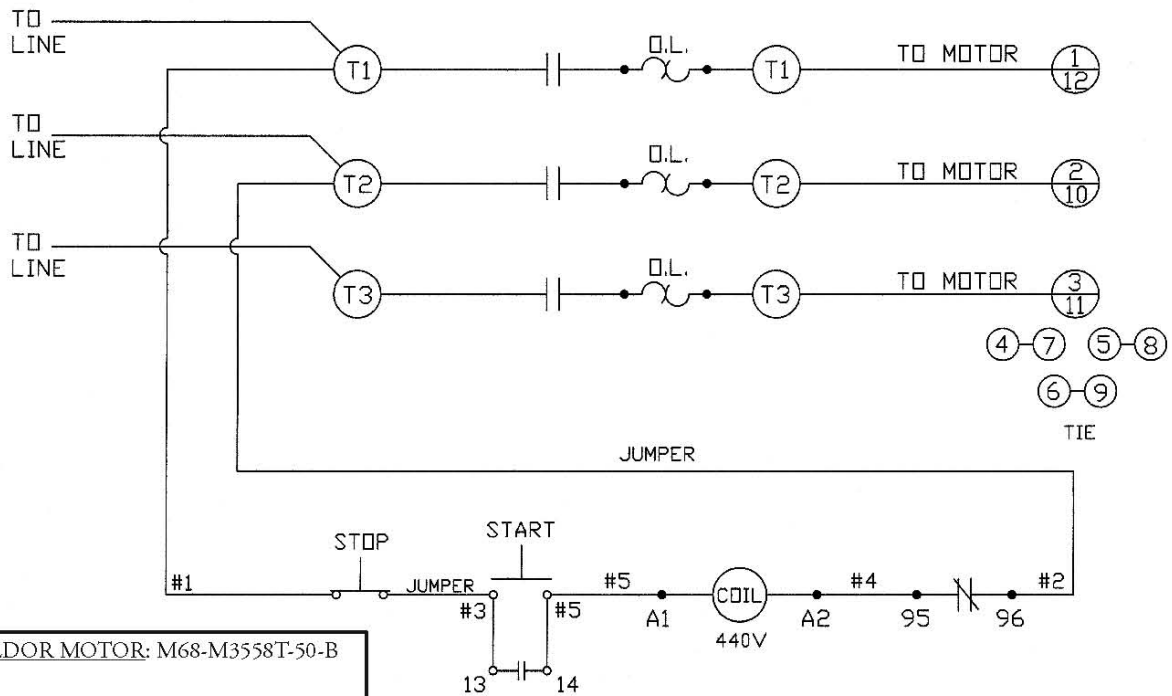

2HP BALDOR MOTOR: M68-M3558T-50-B

CLEANING



SHARP MOVING BAND TYPE SAW BLADE TO AVOID SERIOUS PERSONAL INJURY

ALWAYS Turn Off, Unplug From Power Source and Perform Lockout/Tagout Procedure to This Machine **BEFORE** Cleaning or Servicing.

ONLY Use Recommended Cleaning Equipment, Materials and Procedures.

NEVER Spray Water or Other Liquid Substances Directly at Motor, Power Switch or any Other Electrical Components.

ALWAYS Thoroughly Clean Equipment at Least Daily.

CLEANING THE BIRO POWER CUTTER:

Disconnect electrical power to the machine before cleaning. Parts to be removed have been made accessible and can be removed without tools. Notice in the drawing below that all parts are numbered. Each part should be removed for cleaning in the numbered sequence shown. To ensure cleaner cuts, keep the parts on the cleaning system in good condition. Parts on the cleaning system which should be checked weekly, and changed as required are as follows: Wheel Cleaners (Part No. 179), Saw Cleaners (Part No. 131), Saw Guide in Stationary Bar (Part No. 119A), Upper Saw Guide (Part No. 602B), Lower Blade Back-Up Guide (Part No. 605) and Nylon Filler (Part No. 177).

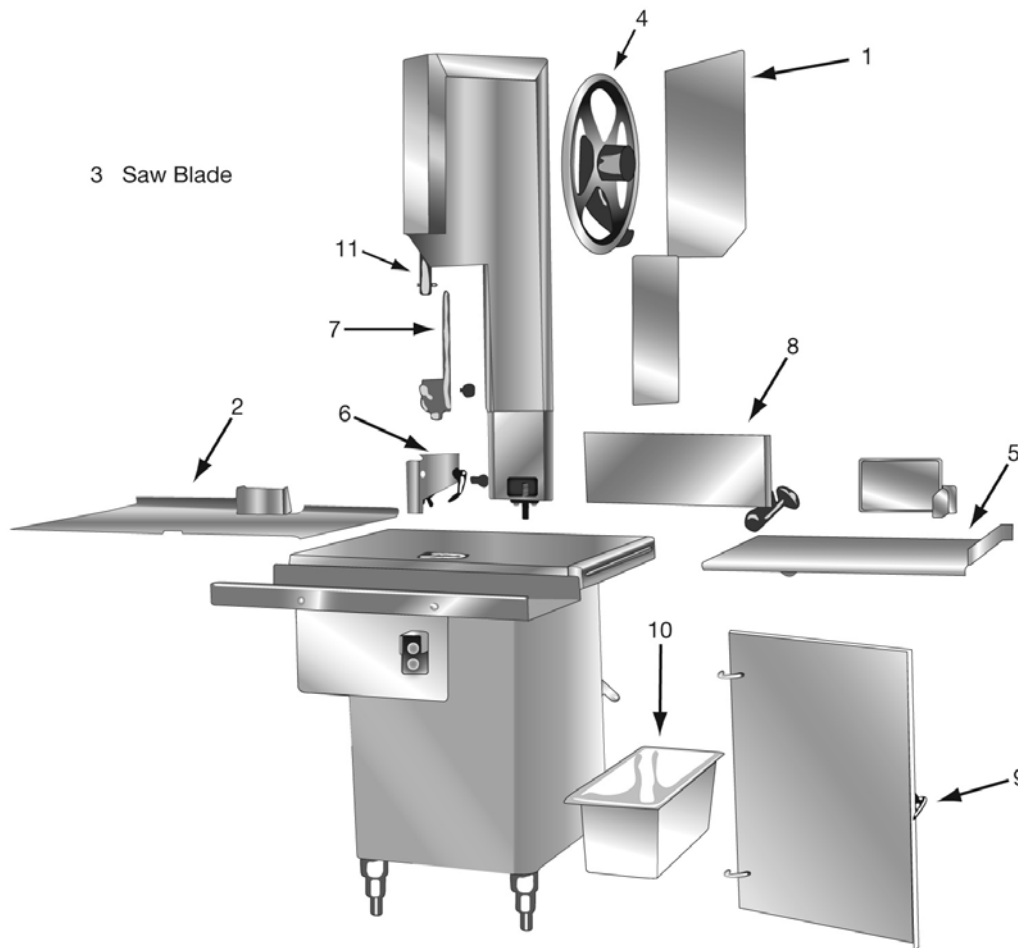

**WEARABLE SAW PARTS THAT WILL FIT BIRO POWER CUTTERS
MODELS**

11-22-1433-33-34-3334-44-4436-55

— EXCEPT WHERE NOTED OTHERWISE —

**CONTACT YOUR NEAREST BIRO AUTHORIZED DISTRIBUTOR
OR CONTACT BIRO MANUFACTURING**

Ph.: 419-798-4451 E-mail: service@birosaw.com



**Item No. 130
SAW CLEANER BRACKET
ALL SAWS**



**Item No. 131
STEEL BLADE CLEANER
ALL SAWS**



**Item No. 159
CARRIAGE BEARING
11-22-33**



**Item No. 16159
CARRIAGE BEARING
1433-34-3334-44-55**

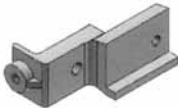

**Item No. 601
UPPER SAW GUIDE BRACKET
ALL SAWS**



**Item No. 602B
UPPER SAW GUIDE
W/BEVELED CARBIDE
ALL SAWS**



**Item No. S265
MEAT GAUGE SPRING
ALL SAWS**



**Item No. S608
LOWER BLADE BACKUP
W/CARBIDE
22 (after S/N 35301)-1433-55**



**Item No. 119A
LOWER SAW GUIDE
ALL SAWS**

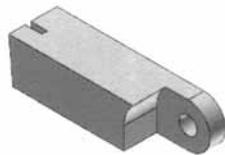

**Item No. 177
NYLON FILLER
ALL SAWS**

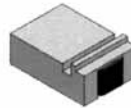

**Item No. 604
LOWER BLADE BACKUP
W/CARBIDE
11-22 (before S/N 35300)**



**Item No. 605
LOWER BLADE BACKUP
W/CARBIDE
34-3334-44-4436**



**Item No. S295
WHEEL CLEANER ARM
ALL SAWS**



**Item No. 179
WHEEL CLEANER
ALL SAWS**



**Item No. S244
WHEEL CLEANER ARM STUD
ALL SAWS**



**Item No. S229
WHEEL CLEANER
ARM SPRING
ALL SAWS**



**Item No. S268
FILLER & GUIDE STUD
ALL SAWS**

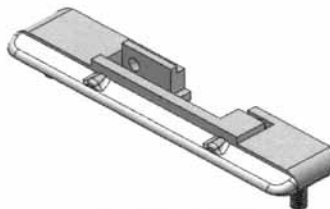

**Item No. 415D
STATIONARY BAR
ALL SAWS**

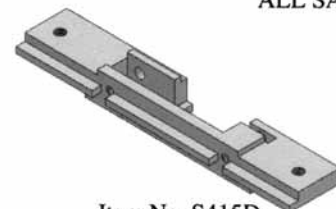

**Item No. S415D
STAINLESS STATIONARY BAR
STD: 22 (after S/N 35301)-1433-55
OPT: 3334-44**

- USE PARTS REPAIR KIT PART NO. 16700 -

MODEL 1433FH
PART NUMBERS AND DESCRIPTIONS
MODEL & SERIAL NO. REQUIRED WHEN ORDERING PARTS

Item No.	Description	Item No.	Description
AN15S	Acorn nut, 1/4-20, SS	14TP-1	Head door hinge pin, short, 1 1/4"
AN20S	Acorn nut, 3/8-16, SS	14R	Hinge receiver
CB98S	Carriage bolt, 3/8-16 x 2 3/4, SS	14TH	Hinge pin holder
HHS048S	Hex head screw, 1/4-20 x 1 1/4, SS	14003U-6	Upper wheel, 14", 6 spoke
HHS0481S	Hex head screw, 1/4-20 x 1 1/2, SS	14003UDF-6	Upper wheel 14", double flange
HHS049NL	Hex screw - nylon 5/16-18 x 1/2 LG	14212W	Platter rod, SS
HHS050S	Hex head screw, 5/16-18 x 5/8, SS	14232	Scrap bucket
HHS060S	Hex head screw, 5/16-18 x 1, SS	14255	Saw guard on saw guide bar w/708 decal
HHS067S	Hex head screw, 3/8-16 x 3/4, SS	S14272	Meat gauge gear rack, SS
HN30S	Hex nut, 3/8-16, light jam, SS	14275	Meat gauge arm
LW15S	Lock washer, 5/16, SS	14275-5	Meat gauge plate w/weld studs
LW25S	Lock washer, heavy 3/8, SS	14301	Model & S/N plate
M66-35M388S508-B	Motor, 2HP, 230-50-1, open	14302HT	Saw blade, 108"
M66-35M388X966-B	Motor, 2HP, 115/230-60-1 open	14313FH-304	Operating and parts manual
M68-67385-D	Motor, 2HP, 208/220/440-50/60-3, TE 7/8	14544	Grease seal, 1.5 O.D.
SSS11SB	Set screw, 1/4-20 x 1/4, w/brass tip	14545	Retaining ring, internal, 2 7/16 ID
SSS15	Set screw, 5/16-18 x 5/16, cup point	14548	Grease seal, 7/8 ID
S12132	Cleaning unit rear	14549	Lower bearing housing cap
S12290	Front blade, wheel cleaner unit	14554	Compression spring
S14005E	Fixed head, SS	14560	Lower wheel, removable, 14" 6 spoke
S14006E	Head door for fixed head, SS	14560DF	Lower wheel 14", double flange
S14007	Channel bracket, SS	14746	T-handle lock, lower wheel
S14214	Side platter bracket, SS	14779-1	Blade tension cap gauge
S14217PD	Base door, left, bolt on, SS	14780	Blade tension adjustment housing
S14217R	Base door, right, hinged, SS	14781	Blade tension adjustment handle
S14239-4	Base, for fixed head, SS	14782	Blade tension screw, SS
14335XE	Upper hinge bracket, fixed head, SS	14783	O-ring
S155-11	Meat carriage stop thumb screw, SS	14785	Plastic washer
S155B-1	Meat carriage stop, welded	14786	O-ring for gauge
S155EZ-3	Hex stand off	14787	Tension screw top collar
S16120	Channel	151	Conduit, watertight, per inch
S163F	Platter spacer weld button, SS	16112	Head door latch
S200B1	Stop stud on saw guide bar	16155EZ	Meat carriage, EZ flow
S229	Wheel cleaner arm spring, SS	16159	Meat carriage bearing
S235	Taper pin, 4 x 3/4, SS	16163B	Platter neck guard, SS
S239-B40	Base foot, welded, SS	16200	Carriage stop movable
S239-B41-4	Adjustable leg bolt, SS	16220-1	Carriage stop fixed
S244	Wheel cleaner arm stud	16251-90X78AL	Upper v-belt pulley 9 x 7/8
S253	Upper wheel aligning screw, SS	163A	Platter hold down clip
S262	Meat gauge release handle, SS	16517	Inner race spacer
S265	Meat gauge release spring, SS	16543	Lower shaft
S268	Stationary bar headless screw, SS	16547	Lower bearing housing
S295	Wheel cleaner arm, stainless	17211-22	Finger lift shim .022
S325	Wheel cleaner arm washer, SS	17211-35	Finger lift shim .035
S360CB-1	Carriage bolt 3/8-16 x 1 1/4 SS	175-1-S	Thumb screw 1/4-20 x 1/2
S415D-2	Stationary bar, SS	175-2-S	Thumb guard nut, SS
S416	Platter locator weld pin, SS	175S	Thumb guard, nylon
S71-3	Upper wheel hinge bracket, fixed head	177	Nylon filler in stationary bar
S608	Lower blade back-up guide w/carbide	179	Wheel cleaner
VTS7181	BIRO logo oval decal	18120EZ-B3	Guide bar, EZ flow, T-shaped
112-212	Waved washer	194	Saw guide bar lock pad, brass
S116-22	Saw guide bar, 22"	194KS-1	Saw guide bar lock knob
119A	Saw guide in stationary bar	196-2	Blade tension spring, fixed head
119FSC	Saw guide in stationary bar, fish	211	Finger lift bracket
12273LH	Meat gauge bracket, left	211A-291Q	Fastener knob, 4 point, 3/8-16
12273RH-3	Meat gauge bracket, right	211D	Finger lift fastener bolt
131	Saw cleaner, SS	211Q	Fastener knob, 4 point, 5/16-18
14TP	Head door hinge pin, long, 1 1/2"	212CP	Platter rod cotter pin
		221-52	V-belt, 52"
		221-53	V-belt, 53"
		224-1	Conduit connector, WT, 180 deg.
		225-1	Conduit connector, WT, 90 deg.

MODEL 1433FH PART NUMBERS AND DESCRIPTIONS (Cont.)

MODEL & SERIAL NO. REQUIRED WHEN ORDERING PARTS

Item No.	Description	Item No.	Description
225-2	Conduit connector, WT, 45 deg.	311-1	Rubber bumper for movable stop
226-28	Conduit connector washer	324	Motor shim $\frac{1}{16}$ " thick
230DL	Upper shaft seal, double lip	324A	Motor shim $\frac{1}{8}$ " thick
234	Grease fitting	331	Platter bracket rubber bumper
237	Up shaft castellated lock nut	360A1	Angled grease fitting
238	Up shaft castellated lock nut washer	374	Shell Cassida grease EPS-2
242R	Base door lock, right	375	Nameplate drive screw
247	Upper shaft	376	Drive screw, #10 x $\frac{1}{2}$, SS
248	Upper wheel hub cap	4-30AL	Motor pulley, 5 x $\frac{3}{4}$, 60 HZ, ali.
249	Base door handle	4-35AL	Motor pulley 5 x $\frac{7}{8}$, 60 HZ, ali.
252X	Upper shaft lock nut	4-45AL	Motor pulley, 6 x $\frac{3}{4}$, 50 HZ, ali.
256P	Safety pusher plate	4-49AL	Motor pulley 5 x $\frac{7}{8}$, 50 HZ, ali.
264-1	Meat gauge release hand wheel	513	Upper wheel hub cap gasket
264G	Hand wheel groove pin	55178	Plunger pin
267	Meat gauge release cotter key	601	Upper guide bracket
270	Meat gauge release pin	602B	Saw guide, upper
271AL	Meat gauge worm gear	602AFSC	Saw guide, upper, fish
272-8	Cap nut, $\frac{3}{16}$ -18, SS	653PC-E	Warning label, English
272-10	Meat gauge lock knob, 4 point	653PC-FR	Warning label, French
272-11	Lock knob socket screw	653PC-SP	Warning label, Spanish
280	Key	658	Label, Made in USA
310	Waved washer	708	Decal, "Danger Exposed Blade"
311	Rubber bumper for fixed stop		

COMPLETE ASSEMBLIES FOR MODEL 1433FH

Item No.	Description	Item No.	Description
AS12132	Rear cleaning unit assembly	A14275	Meat gauge plate assembly
AS12290	Front cleaning unit assembly	A14787	Blade tension spring-screw assembly
AS14005E	Head assembly	A16112	Head door latch assembly
AS14006E	Head door assembly	A16155EZ	Meat carriage assembly, EZ flow
AS14217R	Base door assembly, right	A16200	Carriage stop assembly, movable
AS16120EZ	Channel assembly, EZ flow	A16220-1	Carriage stop assembly, fixed
AS415D-2	Stationary bar assembly	A16547	Lower bearing housing assembly
AS116-2214	Saw guide bar assembly	A227	Upper bearing cup/cone assembly
A14003U-6	Upper wheel assembly w/o hinge plate	A247	Upper shaft and bearing assembly
A14003U335-6E	Upper wheel assembly w/hinge plate	A249R	Base door lock assembly, right
A14163	Stationary platter assembly	A262	Meat gauge release assembly
A14211	Finger lift assembly	A295	Wheel cleaner assembly
AS14273-275	Meat gauge assembly	A363	Lower bearing cup/cone assembly

LIMITED WARRANTY

WARRANTY: The BIRO Manufacturing Company warrants that Model 1433FH will be free from defects in material and workmanship under normal use and with recommended service. BIRO will replace defective parts, which are covered by this limited warranty, provided that the defective parts are authorized for return, shipping charges prepaid, to a designated factory for inspection and/or testing.

DURATION OF WARRANTY: The warranty period for all parts covered by this limited warranty is one (1) year from date of Inspection/Demonstration advised on the returned Warranty Registration card, or eighteen (18) months from original factory ship date, whichever occurs first, except as noted below.

PARTS NOT COVERED BY WARRANTY: The following are **not** covered by this limited warranty: wearable parts on the cleaning system such as wheel cleaners (Item No. 179), saw blade cleaners (Item No. 131), blade backup guides (Item No's. 602B, 605 and 119A), and the nylon filler (Item No. 177). This limited warranty does not apply to machines sold as used, rebuilt, modified, or altered from the original construction in which the machine was shipped from the factory. (WATER CONTAMINATED ELECTRICAL SYSTEMS ARE NOT COVERED UNDER THIS LIMITED WARRANTY.) BIRO is not responsible for electrical connection of equipment, adjustments to switch controls or any other electrical requirements, which must be performed only by a certified electrician. BIRO is not responsible for service charges or labor required to replace any part covered by this limited warranty or for any damages resulting from misuse, abuse, lack of proper or recommended service.

EXCLUSION OF WARRANTIES AND LIMITATION OF REMEDIES: BIRO gives no warranties other than those expressly stated in this limited warranty. THE IMPLIED WARRANTY OF MERCHANTABILITY, THE IMPLIED WARRANTY OF FITNESS FOR PROCESSING FOOD PRODUCTS, AND ALL OTHER IMPLIED WARRANTIES ARE SPECIFICALLY EXCLUDED. BIRO IS NOT LIABLE FOR CONSEQUENTIAL OR INCIDENTAL DAMAGES, EXPENSES, OR LOSSES. THE REMEDIES PROVIDED IN THIS BIRO LIMITED WARRANTY ARE PURCHASER'S SOLE AND EXCLUSIVE REMEDIES AGAINST BIRO.

REGISTRATION CARDS: You must sign, date and complete the warranty registration card supplied with each machine. The warranty card must be returned to The Biro Manufacturing Company for proper registration. If no warranty card is returned to BIRO, the warranty period will begin from the date the machine was originally shipped from the factory.

HOW TO GET SERVICE:

1. Contact the entity from whom you purchased the machine; or
2. Consult the yellow pages of the phone directory for the nearest authorized dealer; or
3. Contact BIRO Mfg. Company for the nearest authorized service entity (250 plus worldwide) in your area.

THE BIRO MANUFACTURING COMPANY

1114 Main Street
Marblehead, Ohio 43440-2099

Ph. 419-798-4451

Fax 419-798-9106

E-mail: Service@birosaw.com

Web: <http://www.birosaw.com>