



HEAVY HORSEPOWER GRINDER OPERATING MANUAL & PARTS LIST

Models 342, 542, 548, 552, 7542, 7548, 7552, 1056, 1556
Applicable on HHP Grinders starting with Serial No. 2250



Model 548
Shown



Model 1056
Shown

BIRO Designed

BIRO Built

☆ IMPORTANT NOTICE ☆
This Manual contains important
safety instructions which must
be strictly followed when using
this equipment.

Item No.
H400-078A
6-17-27-B

TABLE OF CONTENTS:

	PAGE
NOTICE TO OWNERS AND OPERATORS	1
SAFETY TIPS	2
INSTALLATION	3
UNCRATING AND SETUP	3
MOTOR WIRING AND ELECTRICAL REQUIREMENTS	3 & 4
MOTOR SPECIFICATIONS	4
WIRING DIAGRAMS	5
OPERATION	6
TO PROCESS PRODUCT	6
CLEANING	7
MAINTENANCE	8
GRINDING BOWL INSTALLATION	8
BEARING HOUSING LUBRICATION	9
ROLLER CHAIN & DRIVE SPROCKET LUBRICATION	9
MAIN DRIVE CHAIN TENSION	9
OPTIONAL EAGLE DRIVE BELT TENSIONING INSTRUCTIONS	10 & 11
PARTS DIAGRAMS, MAIN BODY AND DRIVE SYSTEM	
FOR 3, 5, 7½ HORSEPOWER GRINDERS	12
WARNING LABELS & LOCATIONS ON GRINDERS	
PARTS DIAGRAMS, BOWL AND TRAY SECTION	
FOR 3, 5, 7½ HORSEPOWER GRINDERS	13
WARNING LABELS & LOCATIONS ON GRINDERS	
ELECTRICAL CONTROLS FOR 3, 5, 7½ HORSEPOWER GRINDERS	14 & 15
PARTS DIAGRAMS, MAIN BODY AND DRIVE SYSTEM	
FOR 10 & 15 HORSEPOWER GRINDERS	16
WARNING LABELS & LOCATIONS ON GRINDERS	
PARTS DIAGRAMS, BOWL AND TRAY SECTION	
FOR 10 & 15 HORSEPOWER GRINDERS	17
WARNING LABELS & LOCATIONS ON GRINDERS	
ELECTRICAL CONTROLS FOR 10 & 15 HORSEPOWER GRINDERS	18
OPERATOR'S NOTES	19 & 20
OPERATOR'S SIGNATURE PAGE	21
LIMITED WARRANTY	22

NOTICE TO OWNERS AND OPERATORS

BIRO's products are designed to process food products safely and efficiently. Unless the operator is properly trained and supervised, however, there is the possibility of a serious injury. It is the responsibility of the owner to assure that this machine is used properly and safely, strictly following the instructions contained in this Manual and any requirements of local law.

No one should use or service this machine without proper training and supervision. All operators should be thoroughly familiar with the procedures contained in this Manual. Even so, BIRO cannot anticipate every circumstance or environment in which its products will be used. You, the owner and operator, must remain alert to the hazards posed by the function of this equipment particularly the ROTATING GRINDING AUGER, which can severely injure an inattentive operator amputating fingers and limbs. No one under eighteen (18) years of age should operate this equipment. If you are uncertain about a particular task, ask your supervisor.

This Manual contains a number of safe practices in the SAFETY TIPS section. Additional warnings are placed throughout the Manual. Warnings related to your personal safety are indicated by:



or



Warnings related to possible damage are indicated by:



BIRO also has provided warning labels on the equipment. If any warning label, instruction label or Manual becomes misplaced, damaged, or illegible, please contact your nearest Distributor or BIRO directly for a replacement.

Remember, however, this Manual or the warning labels do not replace the need to be alert and to use your common sense when using this equipment.

This Manual applies to all machines with serial number 2250 and higher.

- NOTE -

A copy of this manual is included with each HEAVY HORSEPOWER GRINDER.

**The descriptions and illustrations contained in this manual are not binding.
The manufacturer reserves the right to introduce any modification
without updating the manual.**

SAFETY TIPS



ROTATING GRINDING AUGER TO AVOID SERIOUS PERSONAL INJURY

- **NEVER** Touch This Machine without Training and Authorization by Your Supervisor.
- **ALWAYS** Read Operation and Service Manual **BEFORE** Operating, Cleaning or Servicing.
- **NEVER** Place Hands into Machine Input or Output Openings.
- **NEVER** Open Machine During Operation.
- **ONLY** Use a Qualified Electrician to Install According to Local Building Codes: Machine **MUST** Be Properly Grounded.
- **ALWAYS** Connect to **PROPER** Voltage & Phase.
- **ONLY** Install on Level, Non-Skid Surface in a Clean, Well-Lighted Work Area Away from Children and Visitors.
- **NEVER** Use This Machine For Non-Food Products.
- **NEVER** Operate Machine With Tray And/Or Tray Guard Removed or Magnetic Safety Switch By-Passed.
- **ALWAYS** Turn Off, Unplug Machine From Power Source and Perform Lockout/Tagout Procedure to this Machine **BEFORE** Attempting to Unjam or Unclog, Cleaning or Servicing.
- **NEVER** Leave Machine Unattended While Grinder is Running.
- **NEVER** Alter This Machine From its Original Form as Shipped From Factory. **DO NOT** Operate Machine With Missing Parts.
- **PROMPTLY REPLACE** Any Worn or Illegible Warning Labels.
- **ALWAYS** Read Operation and Service Manual **BEFORE** Operating, Cleaning, or Servicing.
- **USE ONLY BIRO** Parts and Accessories Properly Installed.

INSTALLATION



TO AVOID SERIOUS PERSONAL INJURY PROPERLY INSTALL EQUIPMENT IN ADEQUATE WORK AREA

- **ALWAYS** Use Qualified Technician and Electrician for Installation.
- **ALWAYS** Connect to **PROPER** Voltage & Phase.
- **ALWAYS** Install Equipment in Work Area with Adequate Light and Space Away From Children and Visitors.
- **ONLY** Operate on a Solid, Level, Non-Skid Surface.
- **NEVER** Bypass, Alter, or Modify This Equipment in Any Way From Its Original Condition.
- **NEVER** Operate Machine With Tray And/Or Tray Guard Removed or Magnetic Safety Switch By-Passed.
- **NEVER** Operate Without all Warning Labels Attached and Owner/Operator Manual Available to the Operator.

UNCRATING AND SET UP

1. Read this Manual thoroughly before installation and operation. **Do not** proceed with installation and operation if you have any questions or do not understand anything in this Manual. Contact your local Distributor, or **BIRO first**.
2. Install machine on a level, solid, non-skid surface in a well lighted work area away from children and visitors.



ALWAYS LEVEL MACHINE BEFORE USING

3. After installing machine in operational area, it is imperative that the four adjusting legs be adjusted to level the machine and also eliminate rocking.
4. This machine is complete except for a knife and plate. There is a bowl shipping plug (stamped steel) placed in the output end of the grinding bowl to retain the grinding worm during shipment. **REMOVE THE BOWL SHIPPING PLUG AND THE GRINDING WORM.**



5. After checking and making sure the power supply is correct, plug in your machine. **NEVER OPERATE MACHINE WITHOUT TRAY AND GUARD INSTALLED** (Machine will not run with tray removed).
6. Machine must be properly grounded. Use qualified electrician to install according to building codes.

MOTOR WIRING AND ELECTRICAL REQUIREMENTS

- (A) Interchange of current is made in motor outlet box. Leads are properly marked. Changing instructions are on the motor plate or motor outlet box.
- (B) All grinders are wired 220 volts unless otherwise specified. Be sure motor specifications (voltage, cycle, phase) match power supply line. Be sure line voltage is up to specification.
- (C) Electrical connections to be accordance with safety codes and National Electrical Code.

- (D) Rated voltage of the unit shall be identified with full supply voltage.
- (E) Voltage drop on the supply line shall not exceed 10% of full supply voltage.
- (F) The feederline conductor size in the raceway from the branch circuit to the unit must be correct to assure adequate voltage under heavy starting and short overload conditions.
- (G) The feederline conductor shall only be used for the supply of one unit of the relevant horsepower. For connections of more than one unit on the same feederline, a local electrician will have to be consulted to determine the proper conductor size.
- (H) The size of the electrical wiring required from the power source to the grinder on the 3, 5, 7½ HP Grinder is a **MINIMUM OF No. 10 WIRE**. On the 10 & 15 HP Grinder a **MINIMUM OF No. 8 and No. 6** respectively.
- (I) The BIRO Manufacturing Company is not responsible for permanent wiring, connection or installation.



NOTE TO OWNER AND ELECTRICIAN: IF THIS MACHINE IS NOT CORD AND PLUG CONNECTED TO THE ELECTRICAL SUPPLY SOURCE, THEN IT SHOULD BE EQUIPPED WITH, OR CONNECTED TO A LOCKABLE, MANUALLY-OPERATED DISCONNECT SWITCH (OSHA 1010.147)

MOTOR SPECIFICATIONS

HP	KW	VOLTS	HZ	PH	AMPS
5	4	208/220	60	3	17/16
5	4	230	60	1	27
5	4	440	60	3	8
5	4	550	60	3	6.4
7.5	5.5	208/220	60	3	23/22
7.5	5.5	440	60	3	11
10	7.5	208/220	60	3	27/25.6
10	7.5	440	60	3	12.8
10	7.5	550	60	3	10
15	11	208/220	60	3	41/39
15	11	440	60	3	19.5

- 7. Located on the side of the machine is a toggle handle that activates the internal on/off switch. The interlock safety switch is mounted to the top of the internal switch and will break contact with the magnetic starter should the tray be removed.



- 8. Turn the toggle handle to the “ON” position. **CHECK THE ROTATION OF THE WORM DRIVE SHAFT; ROTATION MUST BE COUNTER-CLOCKWISE** as indicated by the rotation decal affixed to the grinding bowl. **ROTATION MUST ONLY BE CHECKED WITH THE GRINDING WORM REMOVED**, otherwise serious irreparable damage may occur to grinding components.
- 9. If the machine runs clockwise (backwards), it must be rewired to correct rotation, otherwise serious irreparable damage may occur to grinding components.
- 10. Insert worm assembly into grinding bowl, place knife (sharp edges out) onto the square end of the worm assembly. The breaker plate slides over the worm knife drive pin, and is held from rotating by pins in the grinding bowl. Put on the retaining ring.



ONLY HAND TIGHTEN END RETAINING RING

For best results, use knife and plate as a set. Do not operate machine for any period of time without product in the grinding bowl. This will cause heating and dulling of the knife and plate.

- 11. Check placement of all warning labels and Manual. Machine is now ready for trained operators to process product.
- 12. Use meat deflector attached to grinding bowl to eliminate meat splatter.
- 13. Contact your local Distributor or BIRO directly if you have any questions or problems with the installation or operation of this machine.

WIRING DIAGRAM FOR HEAVY HORSEPOWER MANUAL FEED GRINDERS
EQUIPPED WITH AEG OR STROMBERG STARTER (3, 5, 7-1/2 HP ONLY)
STARTING WITH SERIAL NUMBER 24808.

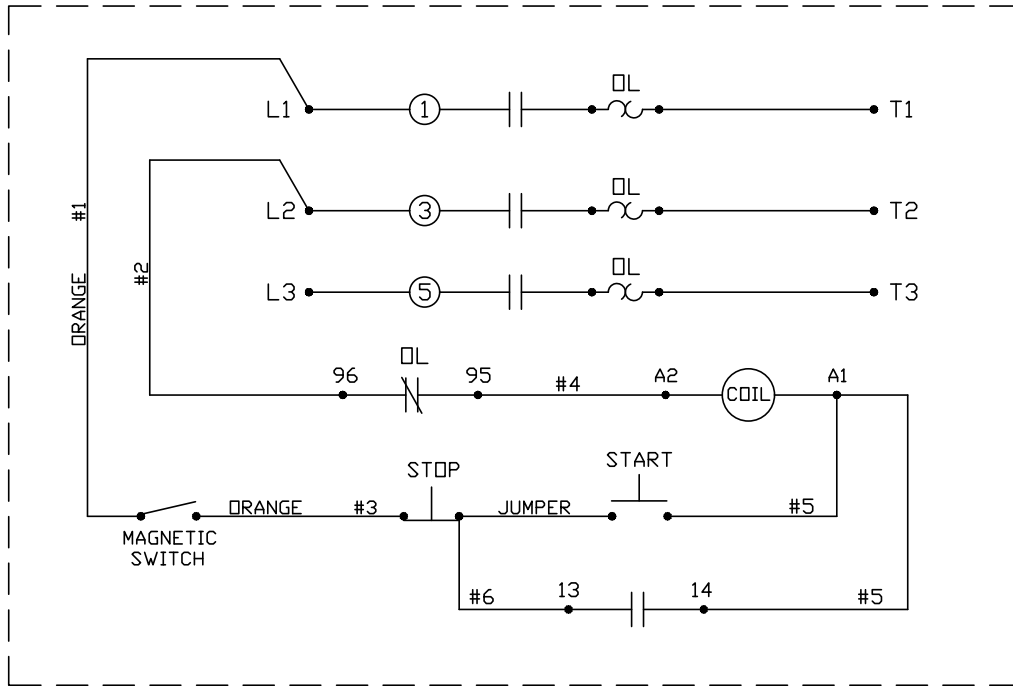

WIRING DIAGRAM FOR HEAVY HORSEPOWER MANUAL FEED GRINDERS
EQUIPPED WITH AEG OR STROMBERG STARTER (10, 15 HP ONLY)

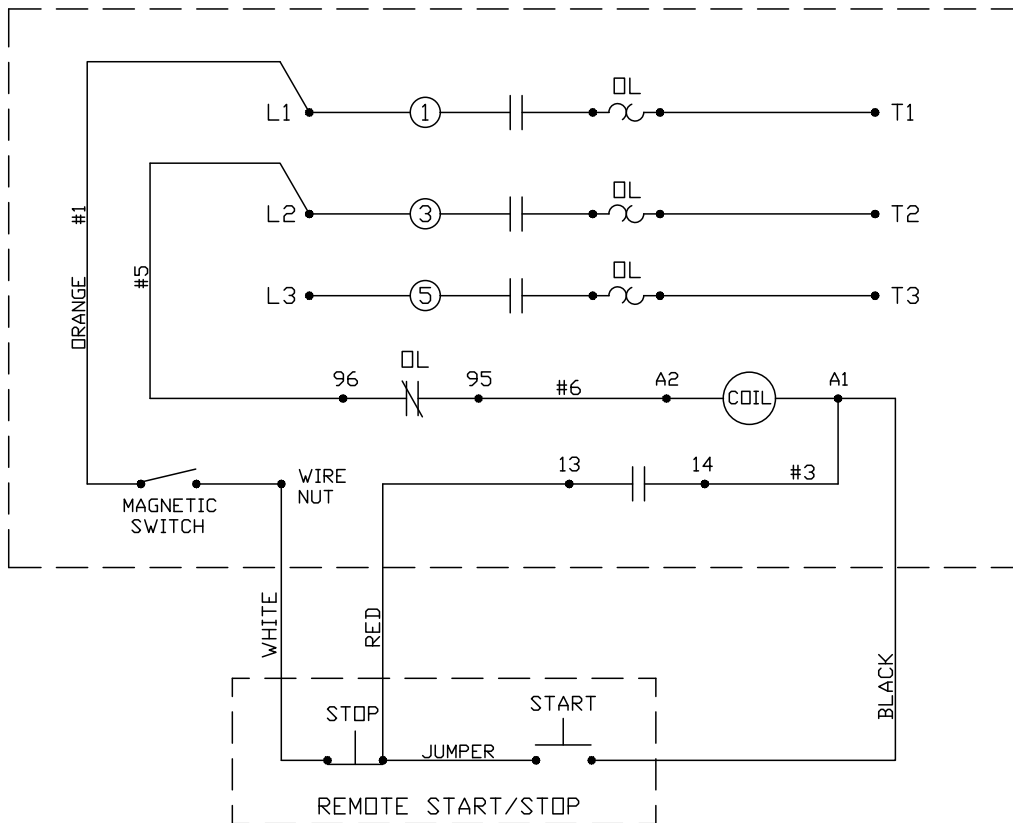

OPERATION



ROTATING GRINDING WORM TO AVOID SERIOUS PERSONAL INJURY

- **ONLY** Properly Trained Personnel Should Use This Equipment.
- **NEVER** Place Hands into Machine Input or Output Openings.
- **NEVER** Open Machine During Operation.
- **DO NOT** Wear Gloves While Operating.
- **DO NOT** Tamper With, Bypass, Alter, or Modify This Equipment in Any Way From Its Original Condition.
- **NEVER** Operate Machine With Tray And/Or Guard Removed, or Magnetic Safety Switch By-Passed.
- **ALWAYS** Turn Off and Unplug Machine from Power Source and Perform Lockout/Tagout Procedure to This Machine **BEFORE** Attempting to Unjam, Unclog, Cleaning or Servicing.
- **NEVER** Leave Machine Unattended While the Grinder is Running.
- **NEVER** Operate Without All Warning Labels Attached and Owner/Operator Manual Available to the Operator.

A. TO PROCESS PRODUCT

1. Before starting the grinder, have meat stomper within easy reach and method of receiving ground product at the output end of the grinding bowl.
2. Turn toggle to “ON” position. Look down grinder bowl and make certain grinding worm is turning in the proper direction (counter-clockwise).
3. Carefully push unground product to top opening of grinding bowl and let drop to grinding worm. Product will then be ground out.



DO NOT REACH DOWN BOWL OPENING

4. Use meat stomper to assist any product that should “bridge up” in grinding bowl opening.
5. When finished grinding turn toggle handle to “OFF” position and unplug grinder from power source and perform lockout/tagout procedure.

DO's

- Always keep knife & plate as matched set.
- Always keep the knife & plate sharp.
- Always check for straightness by laying the knife on the plate before inserting in machine.
- Always install the knife & plate in correct sequence, knife 1st, then plate.
- Always keep knives & plates lubricated in storage and when starting machine.
- Always use coolant when sharpening plates.
- Always inspect the plates making sure all holes are clear - that there are no cracks.

DON'Ts

- Never, never mix different knives to different plates.
- Never, never over tighten the bowl retaining ring on the machine.
- Never, never run the grinder without product. Product is a natural lubricant. Heat can build up so fast that cold product could crack the plate.
- Never, never hit the plate against anything to clean the holes.
- Never, never throw the knives & plates.

CLEANING



ROTATING GRINDING WORM TO AVOID SERIOUS PERSONAL INJURY

- **ALWAYS** Turn Off, Unplug Machine From Power Source and Perform Lockout/Tagout Procedure to this Machine **BEFORE** Cleaning or Servicing.
- **ONLY** Use Recommended Cleaning Equipment, Materials, and Procedures.
- **NEVER** Spray Water or Other Liquid Substances Directly at Motor, Power Switch or any Other Electrical Components.
- **ALWAYS** Thoroughly Clean Equipment at Least Daily.

CLEANING THE BIRO HEAVY HORSEPOWER GRINDER

1. Disconnect grinder from power source and perform lockout/tagout procedures.
2. Remove grinding bowl end ring, breaker plate, knife and grinding worm.



DO NOT POWER SPRAY DIRECTLY AT ELECTRICAL COMPONENTS

3. Machine is now ready to be cleaned using warm soapy water and rinsed with clean water. Machine may be cleaned by power spray washing, taking care not to spray directly at any electrical controls.
4. The grinding bowl can be removed for cleaning if desired. This is accomplished by removing the two nuts on the back flange of the grinding bowl.
5. After machine has been cleaned and allowed to air dry, all exposed metal surfaces should be coated with a good food grade light oil or grease.

CLEANING THE BOWL- RING AND WORM CARE OF TIN COATED PRODUCTS (DO'S AND DON'TS)

1. Do not use abrasive cleaning materials, such as brillo pads or metal scrapers. Tin is a soft metal and should be cleaned with a soft cloth and dried.
2. Do not use a cleaning agent containing a high percentage of free alkali or acid.
3. Do not use a detergent containing a high percentage of tri-sodium phosphate or meta-silicate. Tin is reactive to both.
4. Rinse well and dry thoroughly after washing to remove agents that may be reactive to tin.
5. If sterilizing agent containing chlorine is used, the tinned surface must be thoroughly rinsed. Chlorine is corrosive to tin.
6. Dry thoroughly after rinsing and store in a dry environment.
7. If water is exceptionally hard, drying will be necessary to prevent spotting.

MAINTENANCE



ROTATING GRINDING WORM TO AVOID SERIOUS PERSONAL INJURY

- **ALWAYS** Turn Off, Unplug Machine From Power Source and Perform Lockout/Tagout Procedure to this Machine **BEFORE** Servicing.
- **NEVER** Touch This Machine without Training and Authorization by Your Supervisor.
- **NEVER** Place Hands into Machine Input or Output Openings.
- **NEVER** Bypass, Alter, or Modify This Equipment in Any Way From Its Original Condition.
- **PROMPTLY REPLACE** Any Worn or Illegible Warning Labels.
- **USE ONLY GENUINE BIRO** Parts and Accessories Properly Installed.

A. GRINDING BOWL INSTALLATION

1. Mount the grinding bowl on the two threaded studs on the front of the machine. Tighten in position with provided nuts.
2. Place the grinding worm in the grinding bowl and fully seat rear drive tang into worm drive shaft.
3. Install knife, breaker plate and end retaining ring.



ONLY HAND TIGHTEN RETAINING RING

4. When the bowl assembly is mounted and tight, there should be approximately $\frac{1}{8}$ " gap between the back inside wall of the bowl and the back of the worm (SEE FIGURE 1). The bowl ring wrench which is provided with each grinder is used only for **REMOVAL** of the end retaining ring for cleaning purposes or for changing knife and breaker plate.
5. To check wear: With bowl assembly removed, place a straight edge across outside flange of aluminum bearing housing. The end of the worm drive shaft should just contact the straight edge, i.e. flange face and worm drive shaft end should be in the same plane (SEE FIGURE 2).

FIG. 1

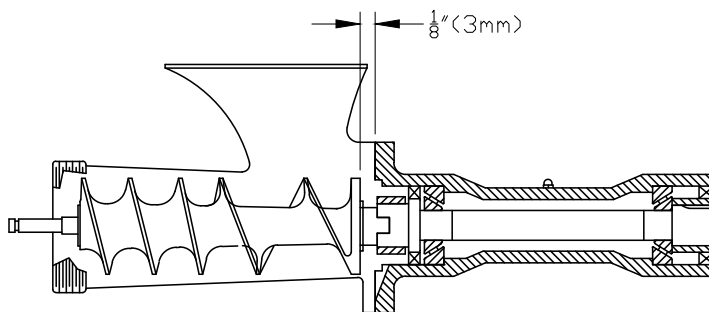
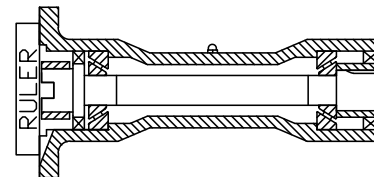

FIG. 2



B. BEARING HOUSING LUBRICATION

1. Unplug grinder from power source and perform lockout/tagout procedures.
2. Remove bolted on tray.
3. Reinstall tray and bolt on tightly.

C. ROLLER CHAIN AND DRIVE SPROCKET LUBRICATION

Chains should be protected against dirt and moisture. Chain life will vary appreciably depending upon its lubrication. The better the lubrication, the longer the chain life.

Lubrication effectiveness will vary with the amount of lubrication and frequency of application. Ideally, a lubricant film should always be present between the working parts. Manually lubricate the chain after the 1st six weeks then every 6 months thereafter.

Lubricating just the outside of the chain does little good. Apply lubrication on the inside of the chain span so that it will work through the moving parts and joints by centrifugal force as the chain rotates and reaches the area where one surface “scrubs” another.

Recommended types of chain lubricant are those with Molybdenum Disulphide or Graphite added. Also bonded lubricants such as Dow Corning’s Molykote 321R or equivalent are excellent for open chains. The lubricant should be of a viscosity whereby it will “flow” somewhat and penetrate the internal working surfaces. Thick stiff greases are of little value because they cannot work into moving parts of the chain.

Symptoms of Inadequate Lubrication:

1. Excessive noise.
2. Chain becomes stiff.
3. Chain runs hot.
4. Broken pins, bushings or rollers.
5. Excessive chain elongation - caused by wear on the pin outside diameter and pushing inside diameter.
Once a chain is elongated or worn past acceptable limits, jumping of sprocket teeth and/or improper chain/sprocket mesh will occur.

LUBRICATING CHAIN AND SPROCKETS

1. Unplug grinder from power source and perform lockout/tagout procedures.
2. Remove bolted on tray.
3. Spray or brush lubricant on inside of chain, slowly and carefully turning large sprocket by hand.
4. Reinstall tray and bolt on tightly.

D. MAIN DRIVE CHAIN TENSIONING

1. Unplug grinder from power source and perform lockout/tagout procedures.
2. Remove feed tray.
3. Loosen motor mounting bolts.
4. Remove shims from under the motor. Important to remove same shims from back of motor as from the front for proper sprocket alignment.
5. Total chain flex should be $\frac{1}{8}$ ” to $\frac{3}{8}$ ” for proper chain tension. Do not over tension as this can cause excessive wear or premature failure of motor bearings and journal box bearings.
6. Retighten all motor mounting bolts.
7. Reinstall feed tray.

OPTIONAL EAGLE BELT DRIVE SYSTEM

BIRO MANUAL FEED GRINDERS

MODELS 548, 552, 7548, 7552, 1056, 1556

FORCE TABLE #1-7

<p>5HP (3.7 kw) new 10.5 lb (4.8 Kg) used 7.7 lb (3.5 Kg)</p>	<p>7-1/2 HP (5.6 kw) new 15.3 lb (6.9 Kg) used 11.2 lb (5.1 Kg)</p>	<p>10HP (7.5 kw) new 15.7 lb (7.1 Kg) used 11.4 lb (5.2 Kg)</p>	<p>15HP (11.2 kw) new 23.1 lb (10.5 Kg) used 16.7 lb (7.6 Kg)</p>
--	--	--	--

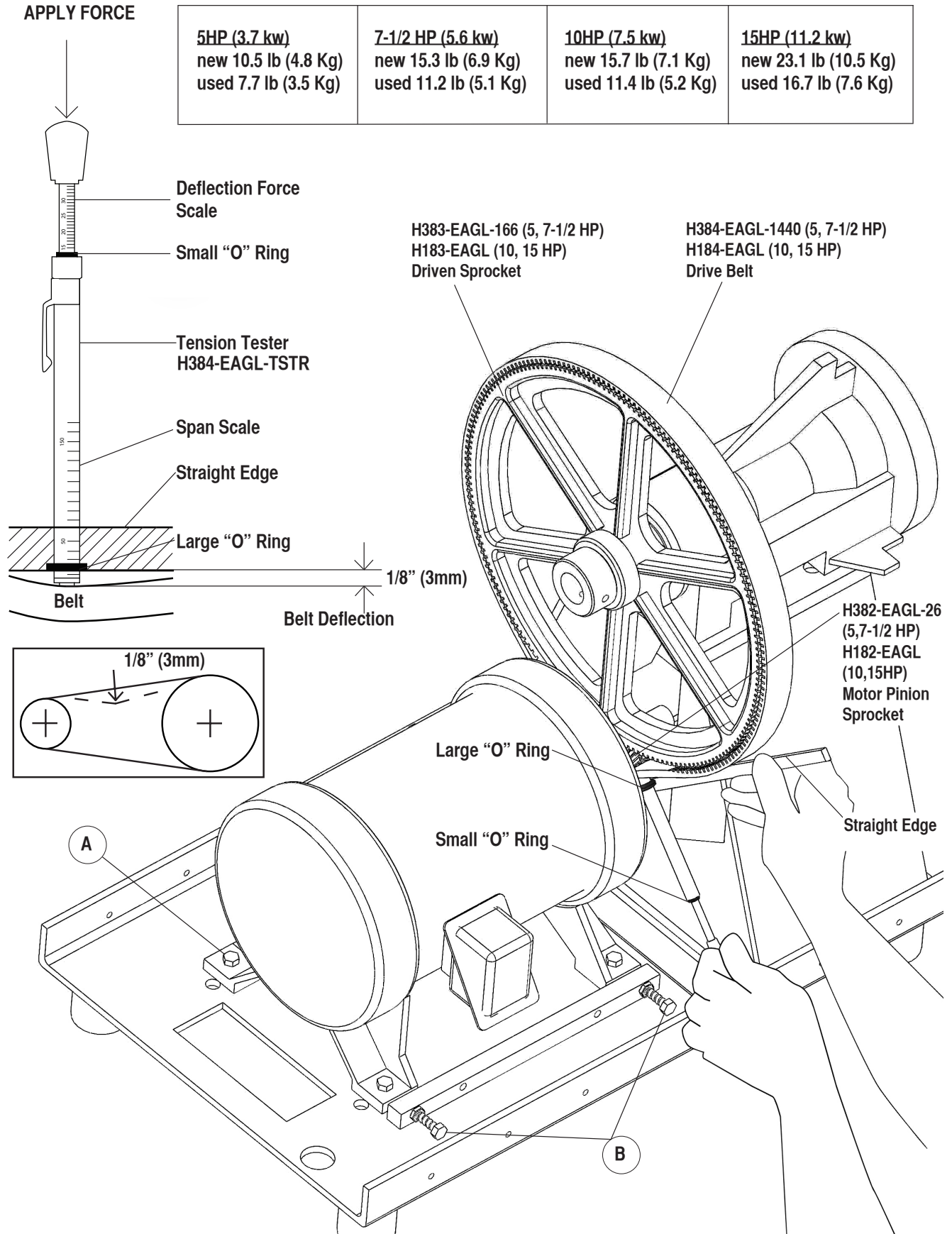

“EAGLE” DRIVE BELT TENSIONING INSTRUCTIONS

MODELS 548, 552, 7548, 7552, 1056, 1556

1. Place a straight edge on top of the belt and across both sprockets as shown in the diagram.
2. Set the large O-Ring at the 1st Graduation ($\frac{1}{8}$ ” line) on the Tension Tester, Item No. H384-EAGL-TSTR.
3. Set the small O-Ring on the deflection force scale to zero.
4. Place the tension tester squarely on the belt at the center of the belt span (see Diagram).
5. Apply a force to the plunger until the large O-Ring is even with the bottom of the straight edge which has been placed across both sprockets ($\frac{1}{8}$ ” belt deflection).
6. Remove the tension tester and read the force recorded from the bottom of the small O-Ring on the force scale.
7. The force should be equal to the value indicated in the force table #1-7 depending on the “HP” of the grinder, and if the belt is “new” or “used.”
8. If the force values do not equal those shown in table #1-7, increase the tension as follows:
 - a. Loosen the 4 motor mounting bolts (A) slightly.
 - b. Advance the jacking screws (B) $\frac{1}{4}$ turn each (be sure to advance both screws an equal amount).
 - c. Retighten the motor mounting bolts.
 - d. Re-check the belt tension according to the above procedure.

Do not rely on “feel” for the proper belt tension as this typically results in belts that are under-tensioned.

Loose belts will fail due to “ratcheting” (jumping a tooth), tooth shearing, and breakage.

IMPORTANT: Must have Model and Serial Number when ordering Parts

MAIN BODY AND DRIVE SYSTEM FOR 3, 5 AND 7½ HORSEPOWER GRINDERS

Applicable on Choppers Starting with Serial No. 2250

Item No.	Description	Item No.	Description	Item No.	Description	
H301	Bearing box, aluminum	H335A	Bevel collar trim 8" w/ fasteners	H379	3 HP, 220/440-50/60-3	
H301A	Bearing box assembly	H346	Connection box	H380-U	5 HP, 220/440-50/60-3	
H302	Main drive shaft, 2 ³ / ₈ x 15 ¹ / ₄ long	H366	Hex nut, 1/2-13, bowl & bowl stud	H380-5B	5 HP, 230-50/60-1	
H303	Shaft collar	H367	Hex head screw, 5/8-11 x 2"	H381-U	7½ HP, 220/440-50/60-3	
H304	Shaft nut, 2 ³ / ₈ x 1 ¹ / ₄ long	H368	Lock washer, 5/8"			
H305	Shaft spacer, 2 ¹ / ₄ x 1 ¹ / ₂ long	H382	Motor pinion- 19 tooth - 60 Hz			
H306	Grease for bearing box	H382-1	Motor pinion- 22 tooth - 50 Hz			
H307	Bearing box grease fitting, 1/8	H383	Sprocket- 141 tooth			
H308	Main shaft key, 3/8 x 3 ⁹ / ₁₆	H384-CL	Roller chain w/ connecting link			
H309	Seal	H384-1	} SEE INSERT "A" AT RIGHT			
H310A	Front bearing cup/cone assembly	H384-2				
H311A	Rear bearing cup/cone assembly	H384-3				
H313	Bowl studs, 1/2 x 3 ¹ / ₄	H386A-B	SS Case assembly			
H317	Switch rod, 20 ³ / ₄ L, before 27182	H389-1	Carriage bolt, 5/16 -18 x 4			
H317-1	Switch rod, 20 ¹ / ₈ L, after s/n 27182	H390	Hex nut, 1/2-13 motor attachment			
H318-1	Switch cam, Nylon	H406	Grease for chain			
H319	Switch handle	H425	Motor shim, 1/8 x 2 x 11"			
H322	Connection box cover	H432	Box end bowl wrench 7/8"			
H324	Base feet, 1 ¹ / ₂ ", black	H462-2	Guard for switch toggle, SS			
H325A	Base plate assembly	H476	Hex nut, 5/16 -18			
H327-11	Aluminum legs, 1 ¹ / ₂ x 11" length	H591	Bushing, switch rod			
H328	Switch lock collar	H591-1	Bushing lock nut			
H331	Roll pin, 1/8 x 3/8	H592	Star washer, switch rod bushing			
H333	Model & Serial number plate	H653-E	Warning label, English			
		H653-SP	Warning label, Spanish			

Item No.	Description
H379	3 HP, 220/440-50/60-3
H380-U	5 HP, 220/440-50/60-3
H380-5B	5 HP, 230-50/60-1
H381-U	7½ HP, 220/440-50/60-3

NOT SHOWN
H487 Retaining nut, 5/16
14572 Ring wrench hanger

INSERT A
To convert machines s/n 2250 to 3173 equipped with 2" Silent Chain, 2½" Silent Chain, or 35-3 Roller Chain will require:
1 Ea. H382 Motor Sprocket
1 Ea. H383 Main Sprocket
1 Ea. H384-CL 35-4 Roller Chain w/ connecting link

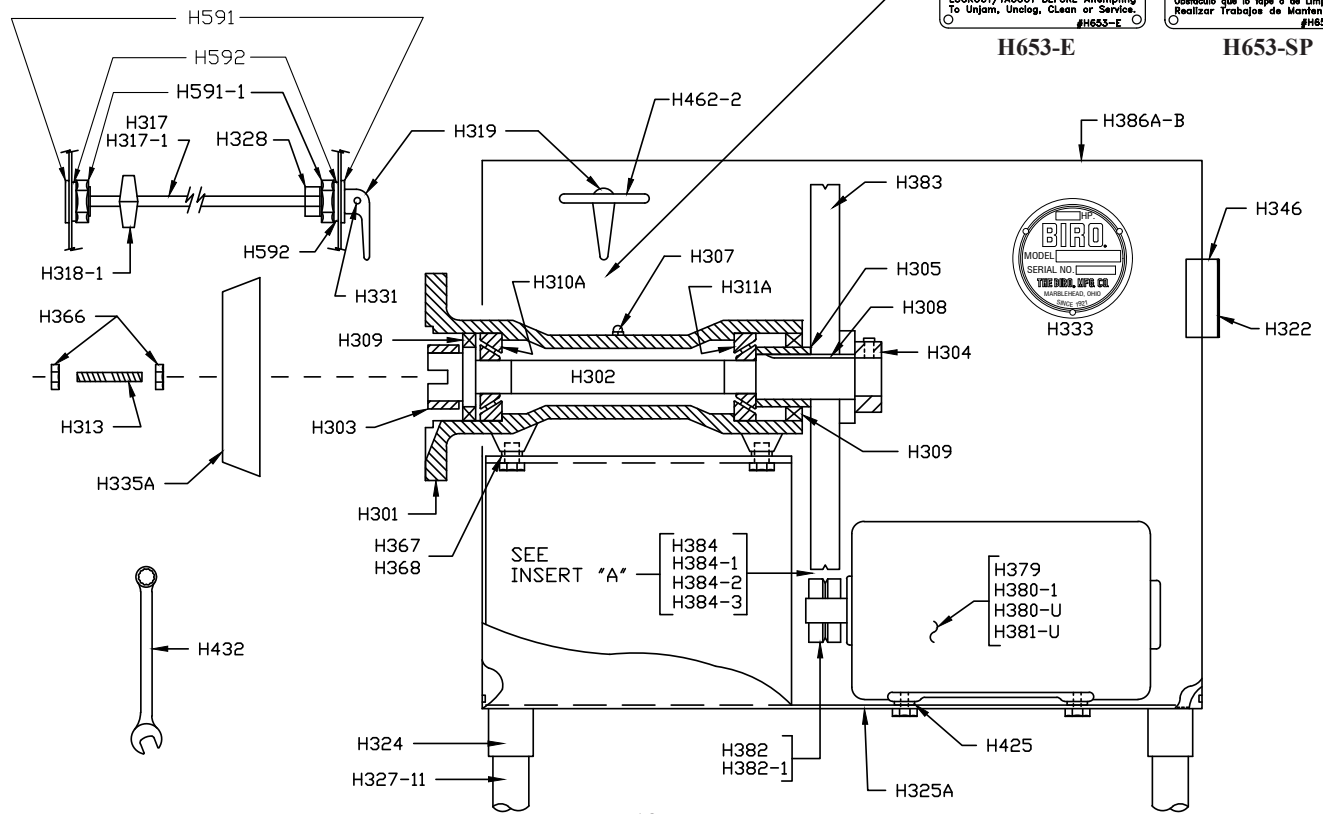
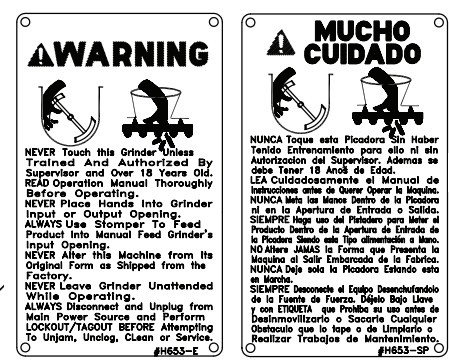

IMPORTANT: Must have Model and Serial Number when ordering Parts

MAIN BODY AND DRIVE SYSTEM FOR 3, 5 AND 7½ HORSEPOWER GRINDERS

Applicable on Choppers Starting with Serial No. 2250

GRINDER HORSEPOWER AND BOWL SIZE AVAILABLE

- Model 342 - 3 HP - #42 size bowl - tinned
- Model 548 - 5 HP - #48 size bowl - tinned
- Model 552 - 5 HP - #52 size bowl - tinned
- Model 7548 - 7.5 HP - #48 size bowl - tinned
- Model 7552 - 7.5 HP - #52 size bowl - tinned

<p>42 Bowl Section</p> <table border="0"> <tr><td>Item No.</td><td>Description</td></tr> <tr><td>HC42A</td><td>Bowl Assembly</td></tr> <tr><td>HC42</td><td>Bowl</td></tr> <tr><td>HS42A</td><td>Worm Assembly</td></tr> <tr><td>HR42/48</td><td>Ring</td></tr> <tr><td>HK48</td><td>Knife drive pin</td></tr> <tr><td>HP48</td><td>Bowl pin</td></tr> <tr><td>H340</td><td>Aluminum ring wrench</td></tr> </table>	Item No.	Description	HC42A	Bowl Assembly	HC42	Bowl	HS42A	Worm Assembly	HR42/48	Ring	HK48	Knife drive pin	HP48	Bowl pin	H340	Aluminum ring wrench	<p>48 Bowl Section</p> <table border="0"> <tr><td>Item No.</td><td>Description</td></tr> <tr><td>HC48A</td><td>Bowl Assembly</td></tr> <tr><td>HC48</td><td>Bowl</td></tr> <tr><td>HS48A</td><td>Worm Assembly</td></tr> <tr><td>HR42/48</td><td>Ring</td></tr> <tr><td>HK48</td><td>Knife drive pin</td></tr> <tr><td>HP48</td><td>Bowl pin</td></tr> <tr><td>H340</td><td>Aluminum ring wrench</td></tr> </table>	Item No.	Description	HC48A	Bowl Assembly	HC48	Bowl	HS48A	Worm Assembly	HR42/48	Ring	HK48	Knife drive pin	HP48	Bowl pin	H340	Aluminum ring wrench	<p>52 Bowl Section</p> <table border="0"> <tr><td>Item No.</td><td>Description</td></tr> <tr><td>HC52A</td><td>Bowl Assembly</td></tr> <tr><td>HC52</td><td>Bowl</td></tr> <tr><td>HS52A</td><td>Worm Assembly</td></tr> <tr><td>HR52</td><td>Ring</td></tr> <tr><td>HK52</td><td>Knife drive pin, fine thread to s/n 26795</td></tr> <tr><td>HK52/56</td><td>Knife drive pin, coarse thread 26796 on</td></tr> <tr><td>HP52</td><td>Bowl pin</td></tr> <tr><td>H340</td><td>Aluminum ring wrench</td></tr> </table>	Item No.	Description	HC52A	Bowl Assembly	HC52	Bowl	HS52A	Worm Assembly	HR52	Ring	HK52	Knife drive pin, fine thread to s/n 26795	HK52/56	Knife drive pin, coarse thread 26796 on	HP52	Bowl pin	H340	Aluminum ring wrench
Item No.	Description																																																			
HC42A	Bowl Assembly																																																			
HC42	Bowl																																																			
HS42A	Worm Assembly																																																			
HR42/48	Ring																																																			
HK48	Knife drive pin																																																			
HP48	Bowl pin																																																			
H340	Aluminum ring wrench																																																			
Item No.	Description																																																			
HC48A	Bowl Assembly																																																			
HC48	Bowl																																																			
HS48A	Worm Assembly																																																			
HR42/48	Ring																																																			
HK48	Knife drive pin																																																			
HP48	Bowl pin																																																			
H340	Aluminum ring wrench																																																			
Item No.	Description																																																			
HC52A	Bowl Assembly																																																			
HC52	Bowl																																																			
HS52A	Worm Assembly																																																			
HR52	Ring																																																			
HK52	Knife drive pin, fine thread to s/n 26795																																																			
HK52/56	Knife drive pin, coarse thread 26796 on																																																			
HP52	Bowl pin																																																			
H340	Aluminum ring wrench																																																			

FOR 3, 5, AND 7.5 HP GRINDERS

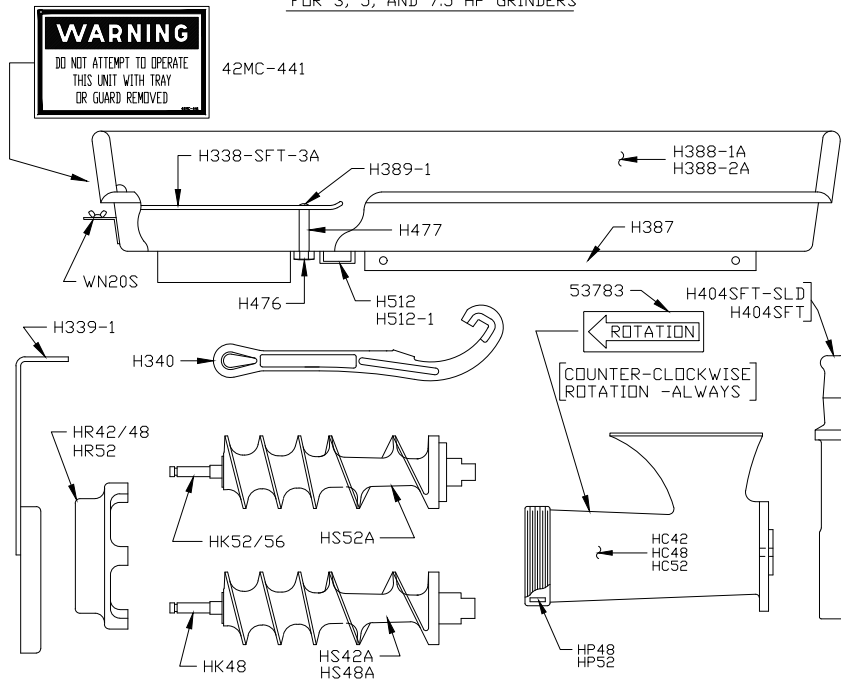

Tray Section For 3, 5, 7.5 Horsepower

Item No.	Description
H339-1	Spurt guard for SS tray
H388-1A	Left hand tray assembly, SS
H388-2A	Right hand tray assembly, SS
H338-SFT-3A	Tray guard assembly for SS tray. (Must be welded)
H387	Tray angles
H389-1	Carriage bolt
H404SFT	Stomper, 12½" long
H404SFT-SLD	Solid Stomper, 12½" long
H476	Hex nut, SS tray only
H477	SS stand off for tray guard
H512	Magnet housing
H512-1	Magnet s/n 26628 on
WN20S	Wing nut, ¾ SS tray only
42MC-441	Warning decal

BOWL, RING, & WORM IDENTIFICATION ALL DIMENSION IN INCHES

MODEL	42	48	52
ITEM NO.	HC42	HC48	HC52
A	5.00	5.00	6-1/2
B	10-9/32	13-27/32	13-7/32

ITEM NO.	HR42/48	HR52
E	7-13/16	9.00
F	MAJOR DIA. 5.00	6-1/2
F	MINOR DIA. 4.81	6.31
G	3-9/16	4-21/32

MODEL	42	48	52
ITEM NO.	HS42A	HS48A	HS52A
C	10-5/16	13-7/8	12-13/16
D	11-13/16	15-3/8	15-1/16

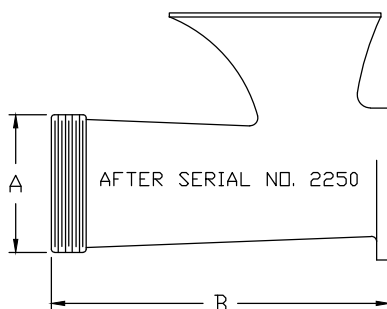

AFTER SERIAL NO. 2250

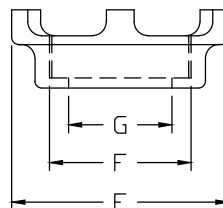

AFTER SERIAL NO. 2250

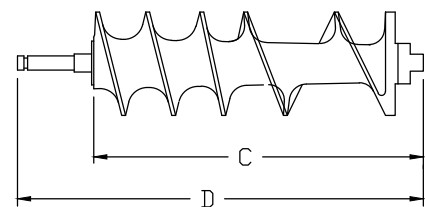

IMPORTANT: Must have Model and Serial Number when ordering Parts

ELECTRICAL CONTROLS 3, 5 AND 7½ HORSEPOWER GRINDERS

FROM SERIAL NO. 2250 TO 5239

ORIGINALLY EQUIPPED WITH ALLEN BRADLEY 609-BAA MANUAL STARTER WITHOUT MAGNETIC SAFETY SWITCH. THESE SWITCHES ARE OBSOLETE AND MUST BE UPDATED TO THE APPROPRIATE AEG EQUIVALENT. ORDER H478EE (SPECIFY HP & VOLTS TO COMPLETE NO.) AEG SWITCH ASSEMBLY LESS BUTTONS. THIS SWITCH ASSEMBLY MUST BE INSTALLED BY A QUALIFIED BIRO SERVICE AGENCY.

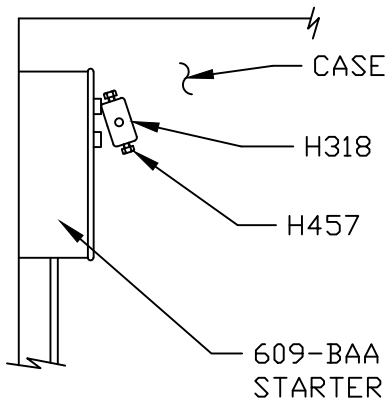
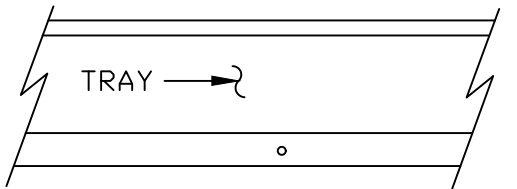

FROM SERIAL NO. 9039 TO 11260

ORIGINALLY EQUIPPED WITH ALLEN BRADLEY 609U-BAA MANUAL STARTER WITH MAGNETIC SAFETY SWITCH. THESE SWITCHES ARE OBSOLETE AND MUST BE UPDATED TO THE APPROPRIATE AEG EQUIVALENT. ORDER H478EE (SPECIFY HP & VOLTS TO COMPLETE NO.) AEG SWITCH ASSEMBLY LESS BUTTONS. THIS SWITCH ASSEMBLY MUST BE INSTALLED BY A QUALIFIED BIRO SERVICE AGENCY.

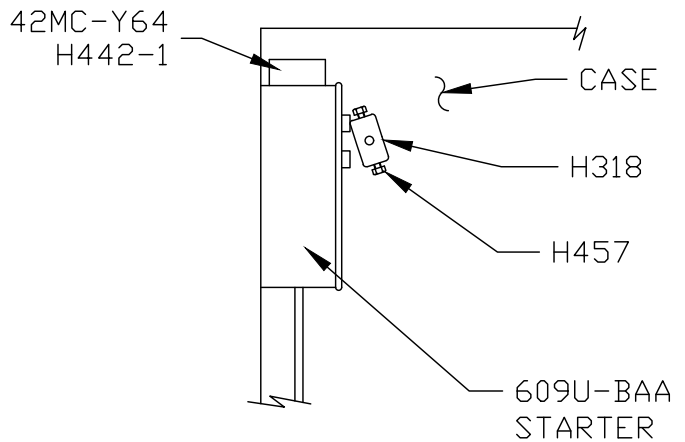
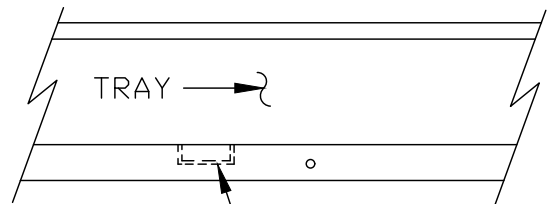

CONVERSION TO AEG STARTER

FROM SERIAL NO. 2250 TO SERIAL NO. 11260 WHEN REPLACING AN ALLEN BRADLEY SERIES 609 STARTER WITH AN AEG STARTER. NEW HOLE LOCATIONS MUST BE DRILLED IN THE MACHINE CASE FOR MOUNTING THE STARTER AND RELOCATING THE SWITCH ROD AS SHOWN IN THE DIAGRAM.

LEFT-HAND SIDE OF CASE

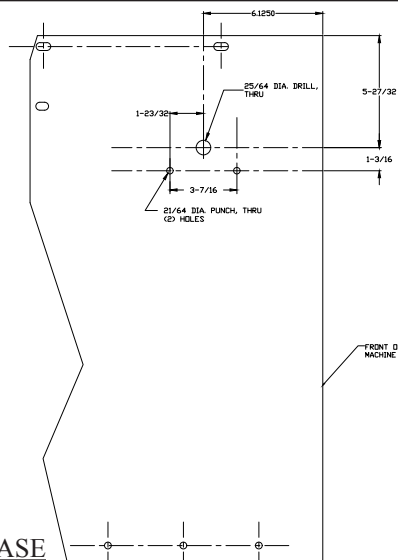

FRONT HALF OF CASE

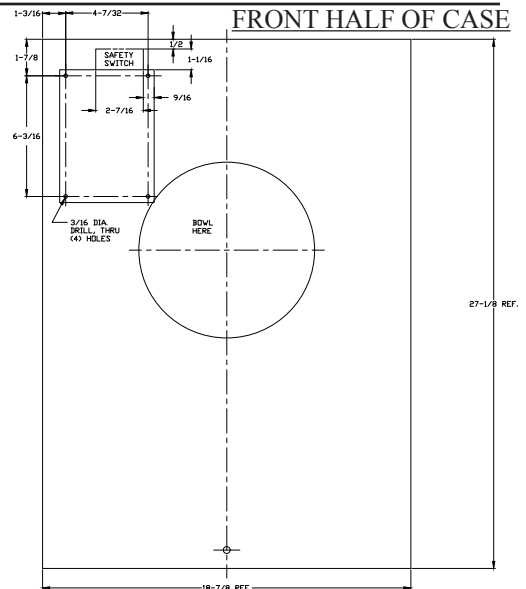

**SERIAL NO. 5240 TO
SERIAL NO. 9038 AND SERIAL NO.
11281 TO SERIAL NO. 24807**

ORIGINALLY EQUIPPED WITH ALLEN BRADLEY 709-BAA MAGNETIC STARTER WITH MAGNETIC SAFETY SWITCH AND AN ALLEN BRADLEY 800S-2SA START-STOP STATION. THE START-STOP STATION IS STILL AVAILABLE, BUT THE 709-BAA IS OBSOLETE AND NOT AVAILABLE. UNITS REQUIRING REPLACEMENT OR REPAIR MUST BE UPDATED WITH THE APPROPRIATE AEG STARTER. ORDER H478EE (SPECIFY HP & VOLTS TO COMPLETE NO.)-LB. AEG SWITCH ASSEMBLY LESS BUTTONS. THIS SWITCH ASSEMBLY MUST BE INSTALLED BY A QUALIFIED BIRO SERVICE AGENCY.

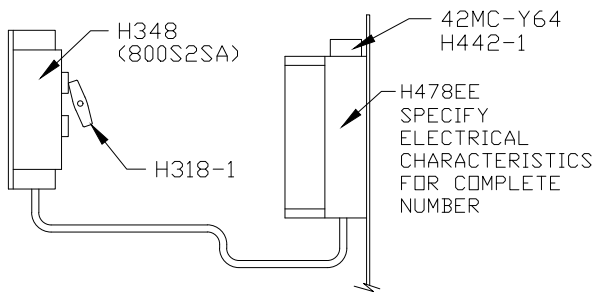

USING 10 & 15 HP WIRING
DIAGRAM ON PAGE 5

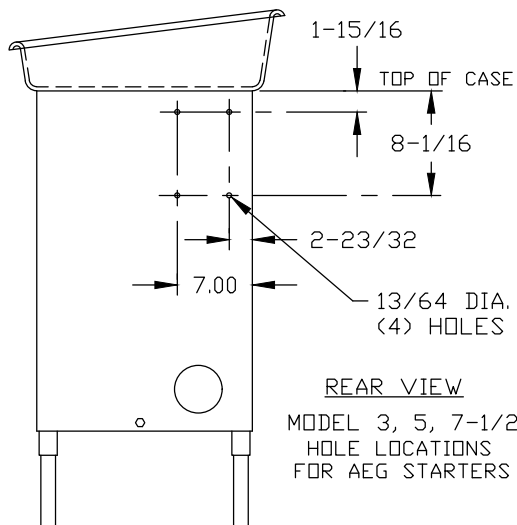

AEG Switch Section

Item No.	Description
H318-1	Switch cam, nylon
42MC-Y64	Magnetic safety switch, low voltage
H442-1	Magnetic safety switch, high voltage
H478EE-21A-LB	Switch Assembly less buttons BAEG/3-C16/LB (208/220V)
H478EE-23A-LB	Switch Assembly less buttons BAEG/3-E6.3/LB (440V)
H478EE-25A-LB	Switch Assembly less buttons BAEG/5-C18/LB (208/220V)
H478EE-27A-LB	Switch Assembly less buttons BAEG/5-E12/LB (440V)
H478EE-30A-LB	Switch Assembly less buttons BAEG/7.5-C26/LB (208/220V)
H478EE-32A-LB	Switch Assembly less buttons BAEG/7.5-E12/LB (440V)

SERIAL NO. 24808 TO 26493

ORIGINALLY EQUIPPED WITH STROMBERG STARTER WITH PUSH BUTTONS AND MAGNETIC SAFETY SWITCH AS ONE UNIT. THE STROMBERG STARTER AND INTERNAL COMPONENTS ARE NO LONGER AVAILABLE. REPLACEMENT REQUIRES UPDATE TO APPROPRIATE AEG EQUIVALENT.

SERIAL NO. 24808 TO PRESENT

EQUIPPED WITH AEG STARTER WITH PUSH BUTTONS AND MAGNETIC SAFETY SWITCH AS ONE UNIT.

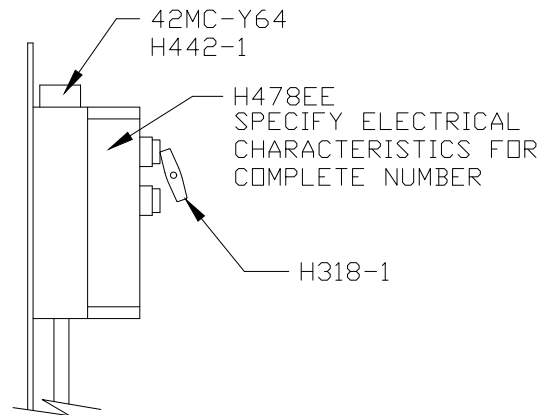

USED ON ALL 3, 5, 7-1/2 HP
GRINDER SWITCH SYSTEMS

AEG Switch Section

Item No.	Description
H318-1	Switch cam, nylon
42MC-Y64	Magnetic safety switch, low voltage
H442-1	Magnetic safety switch, high voltage
H478EE-21A	Switch Assembly BAEG/3-C16 (208/220V)
H478EE-22A	Switch Assembly BAEG/3-D6.3 (380/415V)
H478EE-23A	Switch Assembly BAEG/3-E6.3 (440V)
H478EE-24A	Switch Assembly BAEG/3-F6.3 (550V)
H478EE-25A	Switch Assembly BAEG/5-C18 (208/220V)
H478EE-26A	Switch Assembly BAEG/5-D12 (380/415V)
H478EE-27A	Switch Assembly BAEG/5-E12 (440V)
H478EE-28A	Switch Assembly BAEG/5-F8.5 (550V)
H478EE-29A	Switch Assembly BAEG/5S-C32 (230V-1PH)
H478EE-30A	Switch Assembly BAEG/7.5-C26 (208/220V)
H478EE-31A	Switch Assembly BAEG/7.5-D12 (380/415V)
H478EE-32A	Switch Assembly BAEG/7.5-E12 (440V)
H478EE-33A	Switch Assembly BAEG/7.5-F12 (550V)
226EE-CO11K	Contactor, LS11K.11S-CO (208-230V)
226EE-EO11K	Contactor, LS11K.11S-EO (380V-50Hz/480V-60Hz)
226EE-FO11K	Contactor, LS11K.11S-FO (575V)
H281EE-51	Overload, B18K-K, 4-6.3A
H281EE-52	Overload, B18K-L, 5.5-8.5A
H281EE-53	Overload, B18K-M, 8-12A
H281EE-31	Overload, B18K-N, 10-16A
226EE-OL18O	Overload, B18K-O, 14.5-18A
H281EE-32I	Overload, B18K-ON, 21-26A
4478EE-ENCL-PB	WT Enclosure w/ 30mm pushbutton holes
42MC-Y73	Start button, Green (3, 5, 7.5 HP)
42MC-Y74	Stop button, Red (3, 5, 7.5 HP)

IMPORTANT: Must have Model and Serial Number when ordering Parts

MAIN BODY AND DRIVE SYSTEM FOR 10 AND 15 HORSEPOWER GRINDERS

Applicable on Choppers Starting with Serial No. 2250

Item No.	Description	Item No.	Description
H101	Bearing box	H232	Box end wrench, 1 1/4"
H101A	Bearing box assembly	H306	Grease, for bearing box
H102	Main drive shaft, 3 x 1 5/8"	H307	Bearing box grease fitting
H103	Shaft collar, 3 3/4 x 1"	H308	Main shaft key
H104	Shaft nut	H318-1	Switch cam, nylon
H105	Shaft spacer	H319	Switch handle
H109	Seal	H322	Connection box cover
H110A	Front bearing cup/cone assembly	H324	Base feet, 1 1/2" pipe coupler
H111A	Rear bearing cup/cone assembly	H328	Switch rod collar
H113	Bowl studs, 3/4-10 x 4	H331	Roll pin, 1/8 x 5/8"
H117	Switch rod, 24 1/4 L before s/n 27192	H333	Model & serial number plate
H117-1	Switch rod, 23 3/8 L after s/n 27192	H346	Connection box
H125A	Base plate assembly	H389-1	Carriage bolt, 5/16-18 x 4
H127S-6	Steel legs, 1 1/2 x 6" length	H390	Hex nut, 1/2-13 motor attachment
H135A	Bevel collar trim 10" w/ fasteners	H406	Grease for chain
H182	Motor pinion- 17 tooth- 60Hz	H425	Motor shim, 1/8 x 2 x 11"
H182-1	Motor pinion- 21 tooth- 50 Hz	H462-2	Guard for switch toggle, SS
H183	128 tooth sprocket	H476	Hex nut SS, 5/16-18
H184	3" Silent chain	H591	Bushing, switch rod
H184-1	Master link 1/2 pitch 3"	H591-1	Bushing lock nut
H186A	Case assembly, SS	H592	Star washer, switch rod bushing
H222	Hex nut for bowl stud, 1 1/4"	H653-E	Warning label, English
H224	Motor shim, 1 x 2 x 11"	H653-SP	Warning label, Spanish

Item No.	Motor Section Description
H179-U	10 HP, 220/440-50/60-3
H180-B	15 HP, 220/440-50/60-3

NOT SHOWN	
H487	Retaining nut
14572	Ring wrench hanger

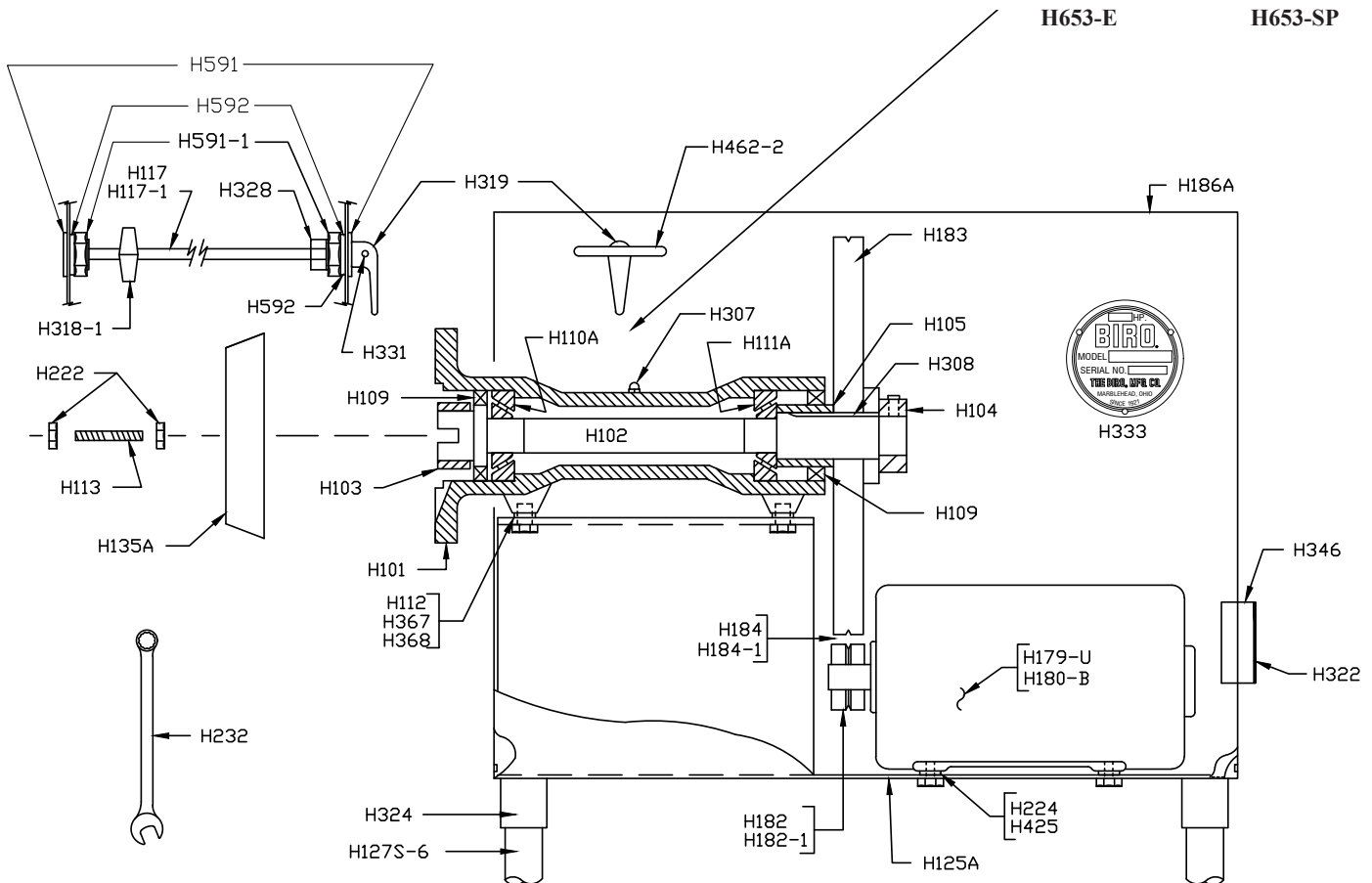

IMPORTANT: Must have Model and Serial Number when ordering Parts

MAIN BODY AND DRIVE SYSTEM
FOR 10 AND 15 HORSEPOWER GRINDERS
 Applicable on Choppers Starting with Serial No. 2250

GRINDER HORSEPOWER AND BOWL SIZE AVAILABLE

Model 1056 - 10 HP - #56 size bowl - tinned

Model 1556 - 15 HP - #56 size bowl - tinned

**Tray Section For
10 and 15 Horsepower**

Item No.	Description	Item No.	Description	Item No.	Description
HC56A	Bowl Assembly	H187	SS tray angle	H476	Hex nut, $\frac{5}{16}$ -18
HC56	Bowl	H188A	Left hand tray assembly, SS	H477	SS stand off for tray guard
HS56A	Worm Assembly	H188-2A	Right hand tray assembly, SS	H512	Magnet housing
HR56	Ring	H338-SFT-3A	Tray guard assembly for SS tray (Must be welded)	H512-1	Magnet s/n 26628 on
HP56	Knife drive pin	H389-1	Carriage bolt, $\frac{5}{16}$ -18 x 4	WN20S	Wing nut
HK52/56	Bowl pin	H404SFT	Stomper, 12 $\frac{1}{2}$ " long	42MC-441	Warning decal
H235	Bowl spurt guard stud	H404SFT-SLD	Solid Stomper, 12 $\frac{1}{2}$ " long	52392	Spurt guard
H340	Aluminum ring wrench				

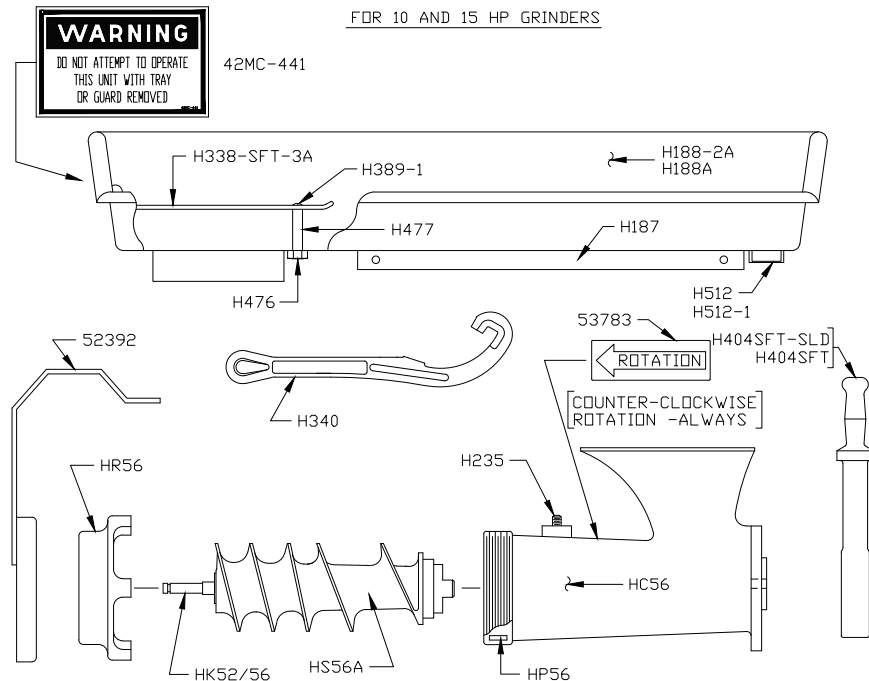

BOWL, RING, & WORM IDENTIFICATION
 ALL DIMENSION IN INCHES

ITEM NO.	HC56
A	6-7/8
B	16-25/32

ITEM NO.	HR56
E	9-5/16
F	MAJOR DIA. 6-7/8 MINOR DIA. 6.68
G	5-3/8

ITEM NO.	HS56A
C	16-7/16
D	18-11/16

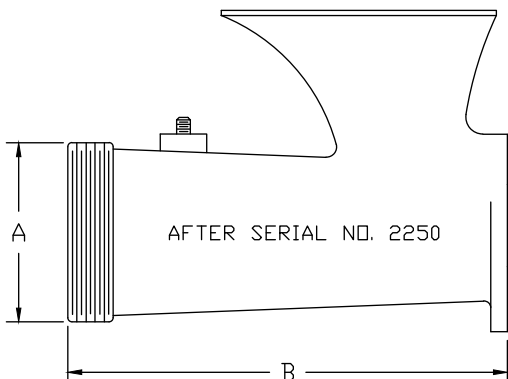

AFTER SERIAL NO. 2250

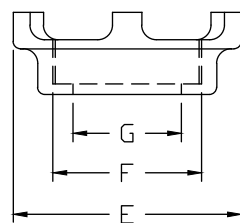

AFTER SERIAL NO. 2250

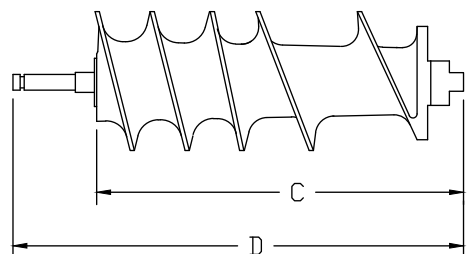

IMPORTANT: Must have Model and Serial Number when ordering Parts

ELECTRICAL CONTROLS 10 AND 15 HORSEPOWER GRINDERS

FROM SERIAL NO. 2250 TO 24729

ORIGINALLY EQUIPPED WITH ALLEN BRADLEY 709-BAA MAGNETIC STARTER WITH MAGNETIC SAFETY SWITCH AND AN ALLEN BRADLEY 800S-2SA START-STOP STATION. THE START-STOP STATION IS STILL AVAILABLE, BUT THE 709-BAA IS OBSOLETE AND NOT AVAILABLE. UNITS REQUIRING REPLACEMENT OR REPAIR MUST BE UPDATED WITH THE APPROPRIATE AEG STARTER. ORDER H478EE (SPECIFY HP & VOLTS TO COMPLETE NO.)-LB. AEG SWITCH ASSEMBLY LESS BUTTONS. THIS SWITCH ASSEMBLY MUST BE INSTALLED BY A QUALIFIED BIRO SERVICE AGENCY.

FROM SERIAL NO. 24780 TO 26586

ORIGINALLY EQUIPPED WITH STROMBERG STARTER WITH MAGNETIC SAFETY SWITCH AND AN ALLEN BRADLEY 800S-2SA START-STOP STATION. THE START-STOP STATION IS STILL AVAILABLE, THE STROMBERG STARTER AND INTERNAL COMPONENTS ARE NO LONGER AVAILABLE. REPLACEMENT REQUIRES UPDATE TO APPROPRIATE AEG EQUIVALENT.

FROM SERIAL NO. 24780 TO PRESENT

EQUIPPED WITH AEG MAGNETIC STARTER AND AN ALLEN BRADLEY 800S-2SA START-STOP STATION.

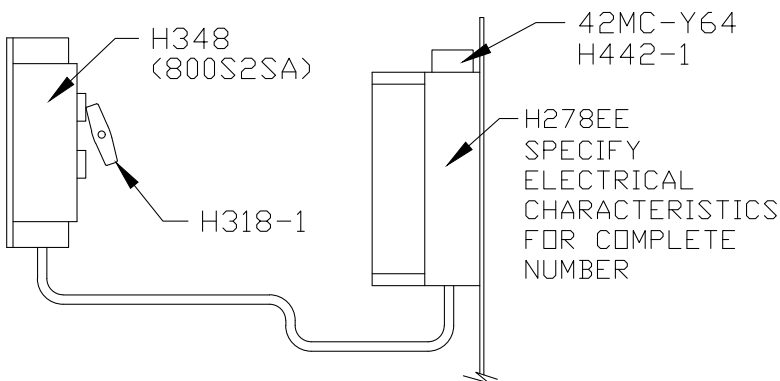

AEG Switch Section

Item No.	Description
H277	SO Cord, 16/4 (10, 15HP)
H478EE-11A	Switch Assembly BAEG/10-C32 (208/220V)
H478EE-12A	Switch Assembly BAEG/10-E16 (380/415V)
H478EE-13A	Switch Assembly BAEG/10-E16 (440V)
H478EE-14A	Switch Assembly BAEG/10-F16 (550V)
H478EE-15A	Switch Assembly BAEG/15-C43 (208/220V)
H478EE-16A	Switch Assembly BAEG/15-D26 (380/415V)
H478EE-17A	Switch Assembly BAEG/15-E22 (440V)
H478EE-18A	Switch Assembly BAEG/15-F22 (550V)
H279EE-220	Contactor, LS18K.10-CO (220V)
H279EE-480	Contactor, LS18K.10-EO (380-480V)
H279EE-550	Contactor, LS18K.10-FO (550V)
H281EE-31	Overload, B18K-N, 10-16A
226EE-OL180	Overload, B18K-O, 14.5-18A
H281EE-321	Overload, B18K-ON, 21-26A
H281EE-34	Overload, B18K-Q, 30-40A
H318-1	Switch cam, nylon
H348	Push button station 800S2SA
42MC-Y64	Magnetic safety switch, low voltage
H442-1	Magnetic safety switch, high voltage

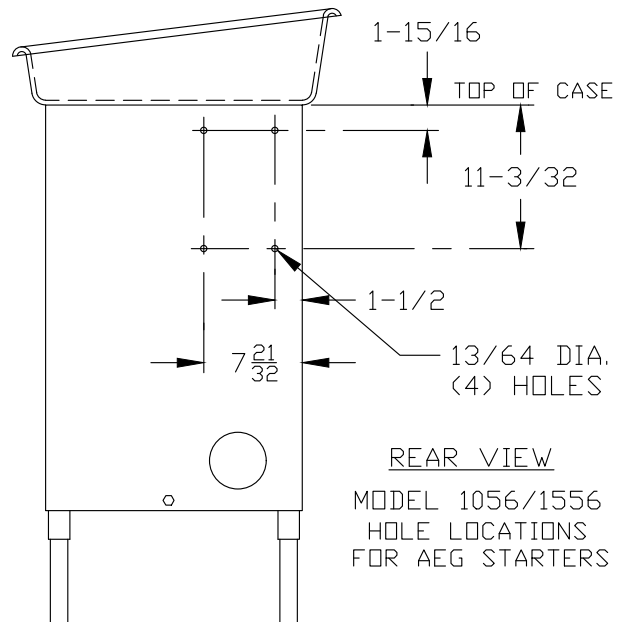

- OPERATOR'S NOTES -

- OPERATOR'S NOTES -

LIMITED WARRANTY

WARRANTY: The BIRO Manufacturing Company warrants that the BIRO Heavy Horsepower Grinder will be free from defects in material and workmanship under normal use and with recommended service. BIRO will replace defective parts, which are covered by this limited warranty, provided that the defective parts are authorized for return, shipping charges prepaid, to a designated factory for inspection and/or testing.

DURATION OF WARRANTY: The warranty period for all parts covered by this limited warranty is one (1) year from date of Inspection/Demonstration as advised on the returned Warranty Registration card, or eighteen (18) months from original factory shipping date, whichever occurs first, except as noted below.

PARTS NOT COVERED BY WARRANTY: The following are **not** covered by this limited warranty: wearable parts in the grinding system such as the bowl, bowl pin, ring, worm, drive shaft, knife drive pin, plate and knife. This limited warranty does not apply to machines sold as used, rebuilt, modified, or altered from the original construction in which the machine was shipped from the factory. (WATER CONTAMINATED ELECTRICAL SYSTEMS ARE NOT COVERED UNDER THIS LIMITED WARRANTY.) BIRO is not responsible for electrical connection of equipment, adjustments to switch components or any other electrical requirements, which must be performed only by a certified electrician. BIRO is not responsible for service charges or labor required to replace any part covered by this limited warranty or for any damages resulting from misuse, abuse, lack of proper or recommended service.

EXCLUSION OF WARRANTIES AND LIMITATION OF REMEDIES: BIRO gives no warranties other than those expressly stated in this limited warranty. THE IMPLIED WARRANTY OF MERCHANTABILITY, THE IMPLIED WARRANTY OF FITNESS FOR PROCESSING OF FOOD PRODUCTS, AND ALL OTHER IMPLIED WARRANTIES ARE SPECIFICALLY EXCLUDED. BIRO IS NOT LIABLE FOR CONSEQUENTIAL OR INCIDENTAL DAMAGES, EXPENSES OR LOSSES. THE REMEDIES PROVIDED IN THIS BIRO LIMITED WARRANTY ARE PURCHASER'S SOLE AND EXCLUSIVE REMEDIES AGAINST BIRO.

REGISTRATION CARDS: You must sign, date and complete the warranty registration card supplied with each machine. The warranty card must be returned to The Biro Manufacturing Company for proper registration. If no warranty card is returned to BIRO, the warranty period will begin from the date the machine was originally shipped from the factory.

HOW TO GET SERVICE:

1. Contact the entity from whom you purchased the machine; or
2. Consult the yellow pages of the phone directory for the nearest authorized dealer; or
3. Contact Biro Mfg. Company for the authorized service entity in your area.

BIRO MANUFACTURING COMPANY

1114 W. Main St.

Marblehead, OH 43440 U.S.A.

Ph: 419-798-4451

Fax: 419-798-9106

service@birosaw.com

www.birosaw.com