



MODEL 922

OPERATION AND SERVICE MANUAL

GRINDER PARTS LIST

GENERAL INSTRUCTIONS

Starting with Serial Number C9861001



★ IMPORTANT SAFETY NOTICE ★

This Manual contains important safety instructions which must be strictly followed when using this equipment.

TABLE OF CONTENTS

	Page
NOTICE TO OWNERS AND OPERATORS	1
SAFETY TIPS	2
INSTALLATION	3
UNCRATING AND SET UP	3
MOTOR WIRING AND ELECTRICAL REQUIREMENTS	4
ELECTRICAL CONTACTORS	5
WIRING DIAGRAMS	5-6
OPERATION	7
TO PROCESS PRODUCT	7
CLEANING	8
MAINTENANCE	9
HIGH TORQUE DRIVE SYSTEM	9
BEARINGS	9
TRAY AND CASE PARTS DIAGRAM	10
TRAY AND CASE PARTS LIST AND PARTS ORDERING	11
BOWL, FRAME AND MOTOR PARTS DIAGRAM	12
OPERATOR'S SIGNATURE PAGE	13
LIMITED WARRANTY	14

NOTICE TO OWNERS AND OPERATORS

BIRO's products are designed to process food products safely and efficiently. Unless the operator is properly trained and supervised, however, there is the possibility of a serious injury. It is the responsibility of the owner to assure that this machine is used properly and safely, strictly following the instructions contained in this Manual and any requirements of local law.

No one should use or service this machine without proper training and supervision. All operators should be thoroughly familiar with the procedures contained in this Manual. Even so BIRO cannot anticipate every circumstance or environment in which its products will be used. You, the owner and operator, must remain alert to the hazards posed by the function of this equipment particularly the ROTATING GRINDING WORM, which can severely injure an inattentive operator amputating fingers and limbs. No one under eighteen (18) years of age should operate this equipment. If you are uncertain about a particular task, ask your supervisor.

This Manual contains a number of safe practices in the SAFETY TIP section. Additional warnings are placed throughout the Manual. Warnings related to your personal safety are indicated by:



OR



Warnings related to possible damage to the equipment are indicated by:



BIRO also has provided warning labels on the equipment. If any warning label or Manual becomes misplaced, damaged, or illegible, please contact your nearest Distributor or BIRO directly for a replacement.

Remember, however, this Manual or the warning labels do not replace the need to be alert and to use your common sense when using this equipment.

This Manual applies to machines with Serial Number C9861001 and higher.

- NOTE -

“A copy of this manual is included with each Model 922 Grinder.”

“The descriptions and illustrations contained in this manual are not binding. The manufacturer reserves the right to introduce any modification without updating the manual .”

SAFETY TIPS



ROTATING GRINDING WORM TO AVOID SERIOUS PERSONAL INJURY

***NEVER** Touch This Machine Without Training and Authorization By Your Supervisor.*

***NEVER** Place Hands Into Machine Input or Output Openings.*

***NEVER** Open Machine During Operation*

***ONLY** Use a Qualified Electrician to Install Electrical Connections According to Local Building Codes:
Machine **MUST** Be Properly Grounded.*

***ALWAYS** Connect to **Proper** Voltage & Phase.*

***ONLY** Install on Level, Non-Skid Surface in a Clean, Well-Lighted Work Area Away From Children
and Visitors.*

***NEVER** Use This Machine For Non-food Products.*

***NEVER** Operate Machine With Tray And/Or Tray Guard Removed or Magnetic Safety Switch By-Passed.*

***ALWAYS** Turn Off, Unplug From Power Source and Perform Lockout/Tagout Procedure to This
Machine **BEFORE** Attempting to Unjam or Unclog, Cleaning or Servicing.*

***NEVER** Leave Machine Unattended While Grinder is Running.*

***NEVER** Alter This Machine From its Original Form as Shipped From Factory. **DO NOT** Operate
Machine With Parts Missing.*

***PROMPTLY REPLACE** Any Worn or Illegible Warning Labels.*

***ALWAYS** Read Operation and Service Manual **BEFORE** Operating, Cleaning or Servicing.*

***USE ONLY BIRO** Parts and Accessories Properly Installed.*

INSTALLATION



TO AVOID SERIOUS PERSONAL INJURY PROPERLY INSTALL EQUIPMENT IN ADEQUATE WORK AREA

ALWAYS Use Qualified Technician and Electrician for Installation.

*ALWAYS Connect to **Proper** Voltage & Phase.*

ALWAYS Install Equipment in Work Area with Adequate Light and Space Away From Children and Visitors.

ONLY Operate on a Solid, Level, Non-Skid Surface.

NEVER Bypass, Alter, or Modify This Equipment in Any Way From Its Original Condition.

NEVER Operate With Tray And /Or Tray Guard Removed or Magnetic Safety Switch By-Passed.

NEVER Operate Without all Warning Labels Attached and Owner/Operator Manual Available to the Operator.

UNCRATING AND SET UP

1. Read this Manual thoroughly before installation and operation. **Do not** proceed with installation and operation if you have any questions or do not understand anything in this Manual. Contact your local Distributor, or BIRO **first**.
2. Install machine on a level, solid, non-skid surface in a well-lighted work area away from children and visitors.
3. This machine is complete **except** for a knife and plate. The grinding bowl assembly is packed separately in the crate. Remove the grinding bowl assembly from the carton. Disassemble the grinding bowl assembly. Assemble the grinding bowl only, onto the front of the grinder. Install the bowl lock handle assembly into the frame under the grinding bowl. Securing the bowl. The back flange of the grinding bowl should be tight against the front of the machine. Do not install grinding worm at this time.



4. Install the feed tray to the top of the grinder. After checking and making sure the power supply is correct, plug in your machine. **NEVER OPERATE MACHINE WITHOUT TRAY AND GUARD INSTALLED.** (Machine will not run with tray removed.)
5. Machine must be properly grounded. Use qualified electrician to install according to building codes.
6. Pushbuttons that activate the internal on/off switch are located on the front of the machine. The interlock safety switch is mounted inside the machine case toward the front and will break contact with the magnetic starter should the tray be removed.

7. Push the green “ON” button. **CHECK THE ROTATION OF THE WORM DRIVE SHAFT. ROTATION MUST BE COUNTER-CLOCKWISE** as indicated by the rotation decal affixed to the grinding bowl. **ROTATION MUST ONLY BE CHECKED WITH THE GRINDING WORM REMOVED**, otherwise serious irreparable damage may occur to grinding components. Push red “STOP” button.
8. If machine runs clockwise (backwards), it must be rewired to correct rotation, otherwise serious irreparable damage may occur to grinding components.
9. Insert worm assembly into grinding bowl, place knife (sharp edges out) onto the square end of the knife drive pin. The breaker plate slides over the worm knife drive pin, and is held from rotating by a pin in the grinding bowl. Put on the retaining ring.



ONLY HAND TIGHTEN RETAINING RING

For best results, use knife and plate as a set. **Do not operate machine for any period of time** without product in the grinding bowl. This will cause heating and dulling of the knife and plate.

10. Check placement of all warning labels and Manual. Machine is now ready for trained operators to process product.
11. Contact your local Distributor or BIRO directly if you have any questions or problems with the installation or operation of this machine.

MOTOR WIRING AND ELECTRICAL REQUIREMENTS

- (1) Interchange of current is made in motor outlet box. Leads are properly marked. Changing instructions are on the motor plate or motor outlet box. Electrical contactor mounted on machine frame must also be changed to match motor voltage.
- (2) All grinders are wired for the voltage as ordered. Be sure motor specifications (voltage, cycle, phase) match power supply line. Be sure line voltage is up to specification.
- (3) Electrical connections to be in accordance with safety codes and National Electrical Code.
- (4) Rated voltage of the unit shall be identical with full supply voltage.
- (5) Voltage drop on the supply line shall not exceed 10% of full supply voltage.
- (6) The feederline conductor size in the raceway from the branch circuit to the unit must be correct to assure adequate voltage under heavy starting and short overload conditions.
- (7) The BIRO Manufacturing Company is not responsible for permanent wiring, connection or installation.



NOTE TO OWNER AND ELECTRICIAN: IF THIS MACHINE IS NOT CORD AND PLUG CONNECTED TO THE ELECTRICAL SUPPLY SOURCE, THEN IT SHOULD BE EQUIPPED WITH, OR CONNECTED TO, A LOCKABLE, MANUALLY-OPERATED DISCONNECT SWITCH (1010.147 OSHA).

ELECTRICAL CONTACTORS

- (1) Most 1 HP motors are dual voltage and can be changed according to wiring diagram on motor nameplate.
- (2) Be sure contactor voltage matches voltage of motor.

A. Item No. C903-922 Contactor 1 HP, 104-60-1 1 HP, 115-60-1 1 HP, 380/415/440-50/60-3 w/ 56110 transformer	B. Item No. C903-1-922 Contactor 1 HP, 220-50/60-3 1 HP, 208/230-60-1 1 HP, 240-50-1 1½ HP, 230-60-1
--	--
- (3) FAILURE TO USE PROPER CONTACTOR FOR MOTOR VOLTAGE WILL CAUSE IRREPARABLE DAMAGE TO CONTACTOR.
- (4) Install proper plug on power cord for voltage used.

WIRING DIAGRAMS

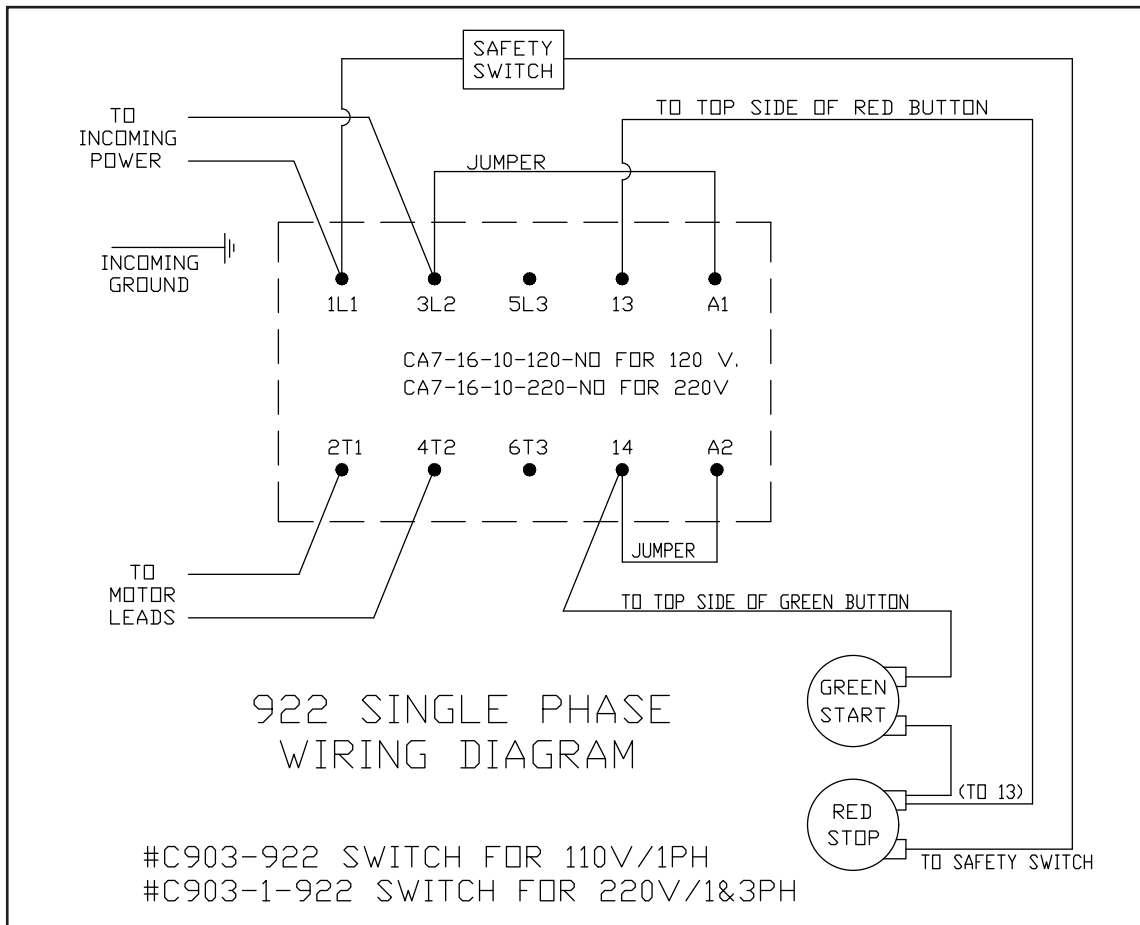

**MOTOR CONNECTION FOR
#C930-4 BALDOR MOTOR 220V/1PH/60HZ
1 to T1 / 4-5 to T2 / 2-3-8 TOGETHER**

WIRING DIAGRAMS CONTINUED

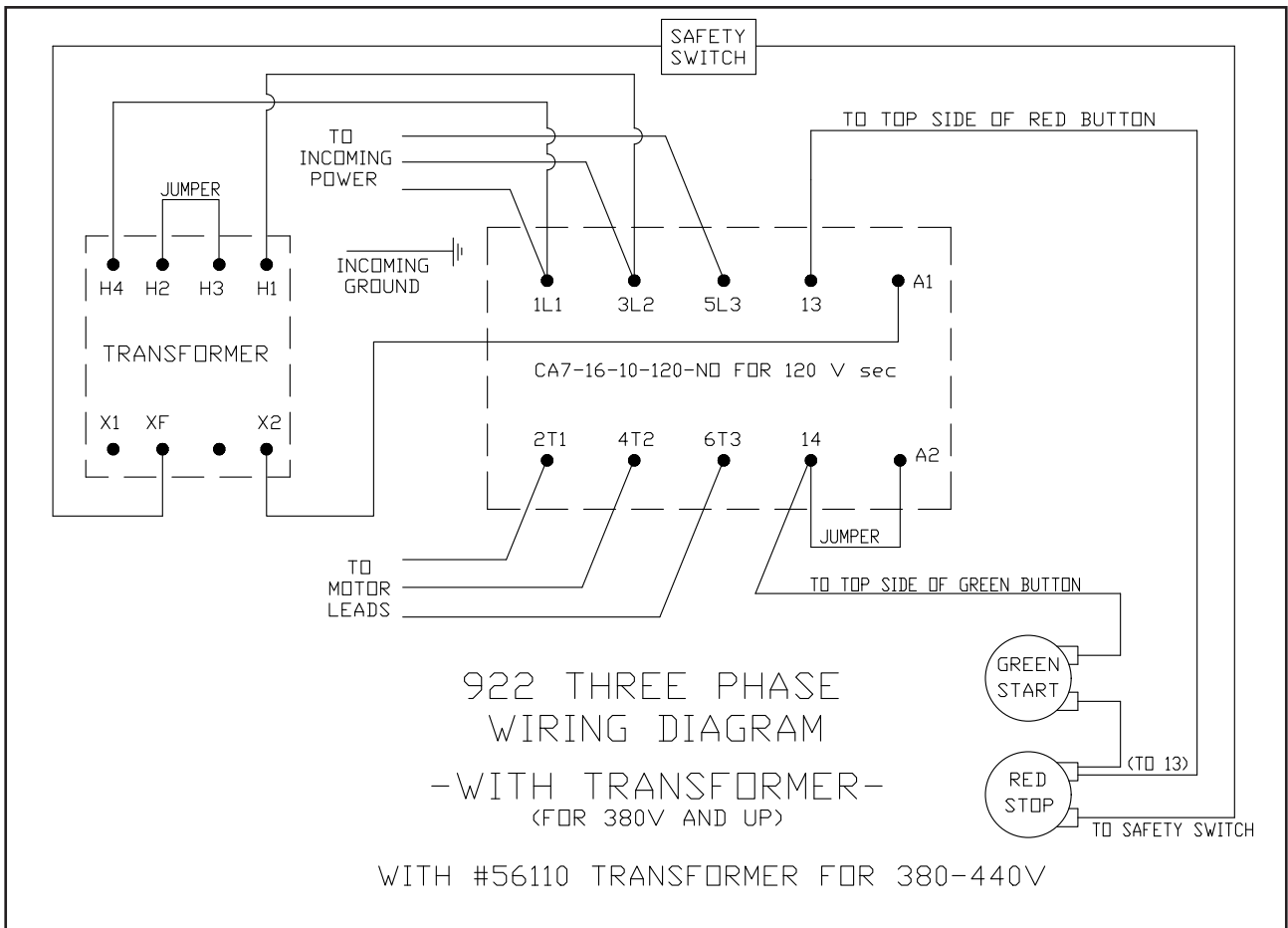
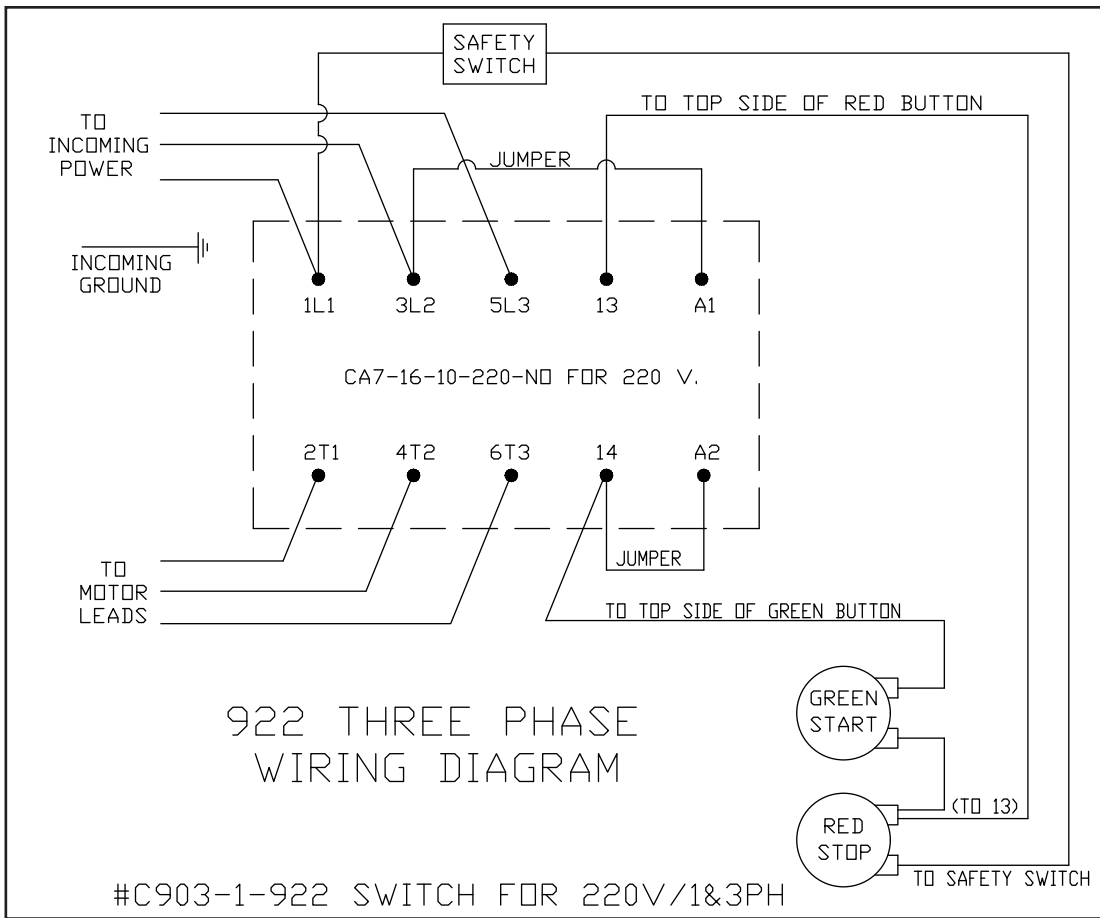

OPERATION



ROTATING GRINDING WORM TO AVOID SERIOUS PERSONAL INJURY

***ONLY** Properly Trained Personnel Should Use This Equipment.*

***NEVER** Place Hands Into Machine Input or Output Openings.*

***NEVER** Open Machine During Operation.*

***DO NOT** Wear Gloves While Operating.*

***DO NOT** Tamper With, Bypass, Alter, or Modify This Equipment in Any Way From Its Original Condition.*

***NEVER** Operate Machine With Tray And/Or Tray Guard Removed or Magnetic Safety Switch By-Passed.*

***ALWAYS** Turn Off, Unplug From Power Source and Perform Lockout/Tagout Procedure to This Machine **BEFORE** Unjamming, Unclogging, Cleaning or Servicing.*

***NEVER** Leave Unattended While Grinder is Running.*

***NEVER** Operate Without all Warning Labels Attached and Owner/Operator Manual Available to the Operator.*

A. TO PROCESS PRODUCT

1. Before starting grinder, have meat stomper within easy reach and a container for receiving ground product at the output end of grinding bowl.
2. Push the green “ON” button. Look down grinder bowl and make certain grinding worm is turning in the proper direction (counter-clockwise).
3. Carefully push unground product to top opening of grinding bowl and let drop onto the grinding worm. Product will then be ground out.



DO NOT REACH DOWN BOWL OPENING

4. Use meat stomper to assist any product that should “bridge up” in grinding bowl opening.
5. When finished grinding, push the red “OFF” button and unplug grinder from power source and perform lockout/tagout procedures.

CLEANING



ROTATING GRINDING WORM TO AVOID PERSONAL INJURY

ALWAYS Turn Off, Unplug From Power Source and Perform Lockout/Tagout Procedure to This Machine **BEFORE** Cleaning or Servicing.

ONLY Use Recommended Cleaning Equipment, Materials and Procedures.

NEVER Spray Water or Other Liquid Substances Directly at Motor, Power Switch or any Other Electrical Components.

ALWAYS Thoroughly Clean Equipment at Least Daily.

CLEANING THE BIRO MODEL 922 GRINDER

1. Disconnect grinder from power source and perform lockout/tagout procedures.
2. Remove the feed tray.
3. Remove grinding bowl end ring, breaker plate, knife, grinding worm and the grinding bowl.



DO NOT SPRAY DIRECTLY AT ELECTRICAL COMPONENTS

4. Machine is now ready to be cleaned using warm soapy water and rinsed with clean water. Machine may be cleaned by power spray washing, taking care to not spray directly at any electrical controls.
5. After machine has been cleaned and allowed to dry, all exposed metal surfaces should be coated with a good food grade light oil or grease.

CLEANING THE BOWL- RING AND WORM CARE OF TIN COATED PRODUCTS (DO'S AND DON'TS)

1. Do not use abrasive cleaning materials, such as brillo pads or metal scrapers. Tin is a soft metal and should be cleaned with a soft cloth and dried.
2. Do not use a cleaning agent containing a high percentage of free alkali or acid.
3. Do not use a detergent containing a high percentage of tri-sodium phosphate or meta-silicate. Tin is reactive to both.
4. Rinse well and dry thoroughly after washing to remove agents that may be reactive to tin.
5. If sterilizing agent containing chlorine is used, the tinned surface must be thoroughly rinsed. Chlorine is corrosive to tin.
6. Dry thoroughly after rinsing and store in a dry environment.
7. If water is exceptionally hard, drying will be necessary to prevent spotting.

MAINTENANCE



ROTATING GRINDING WORM TO AVOID SERIOUS PERSONAL INJURY

ALWAYS Turn Off, Unplug From Power Source and Perform Lockout/Tagout Procedure to This Machine **BEFORE** Servicing.

NEVER Touch This Machine Without Training and Authorization By Your Supervisor.

NEVER Place Hands Into Machine Input or Output Openings.

NEVER Bypass, Alter, or Modify This Equipment in Any Way From Its Original Condition.

PROMPTLY REPLACE Any Worn or Illegible Labels.

USE ONLY GENUINE BIRO Parts and Accessories Properly Installed.

A. HIGH TORQUE DRIVE SYSTEM

The Model 922 is driven by a High Torque Drive system for power transmissions.

“No Lubrication” is required (in fact) be sure no lubricant comes in contact with the sprockets or belt.

To ensure a long life to the drive components:

1. Be sure the motor shaft and main drive shaft are parallel.
2. Be sure sprockets are in alignment.
3. Proper HTD belt tension is $\frac{3}{32}$ “ on one side.
Tension should be checked every six (6) months.

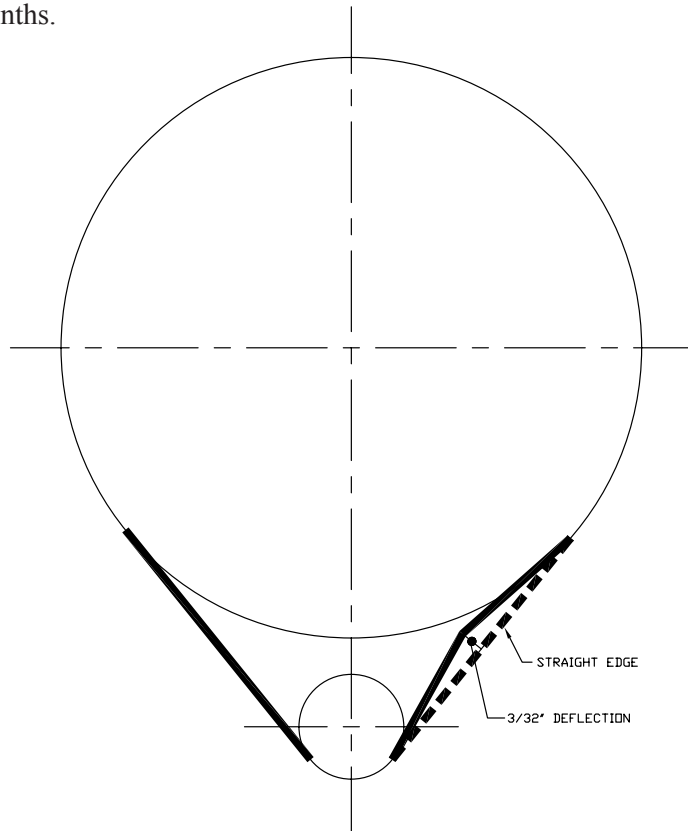

B. BEARINGS

1. The main drive shaft bearings are sealed for life. No need to lubricate.
2. The motor bearings are sealed for life. No need to lubricate.

TRAY AND CASE PARTS

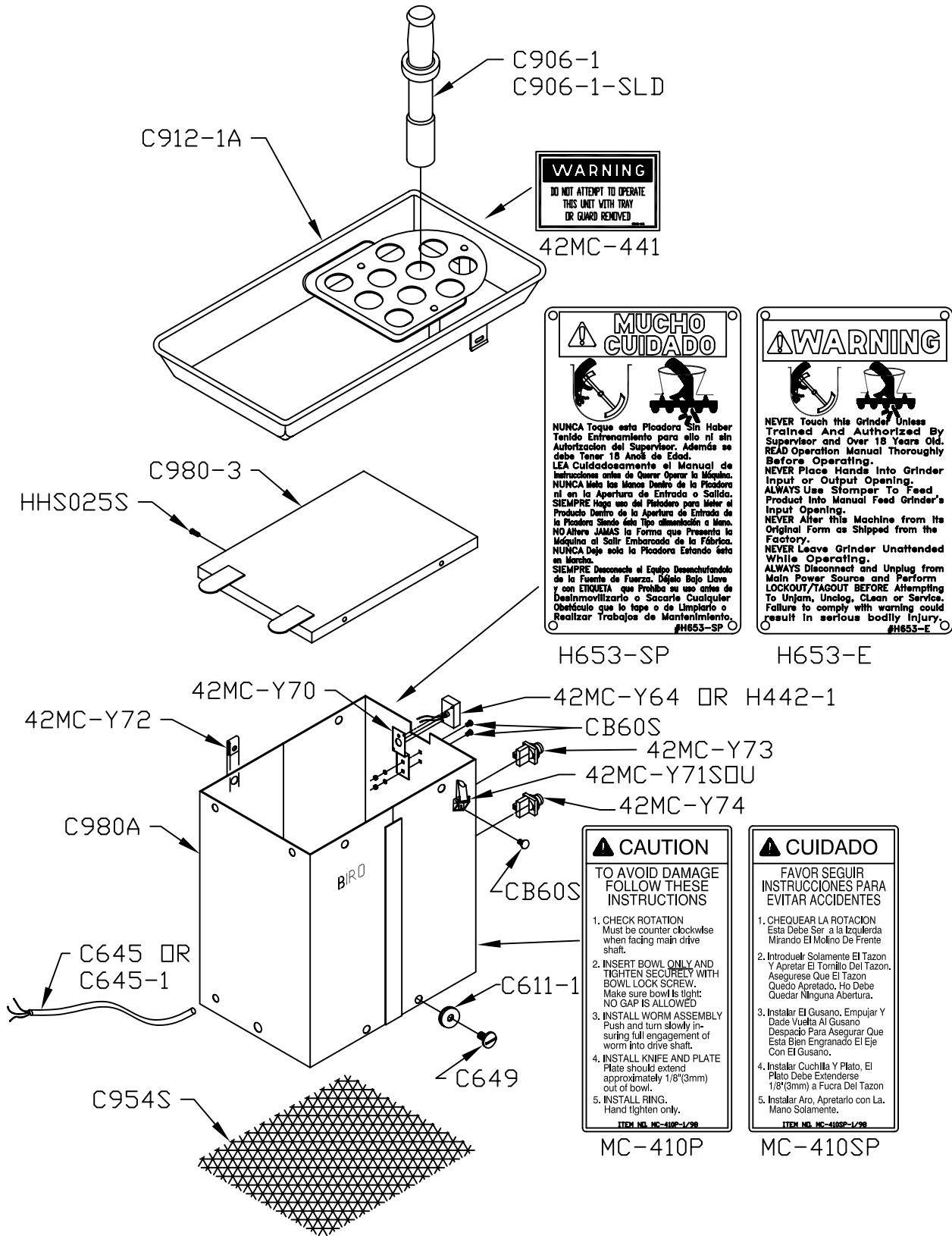

TRAY AND CASE PARTS LIST

NOTE: SPECIFY MODEL & SERIAL NUMBER WHEN ORDERING PARTS

Item No.	Description
CB60S	Carriage bolt, ¼ - 20 x ½, SS
C611-1	Rubber Grommet
C627-1	Voltage wiring (decal)
C645	Cord for 3 Phase, 14/4 SO
C645-1	Cord for 1 Phase, 14/3 SO
C649	Case to base screw, 5/16-18 x ¾
C906-1	Stomper
C906-1-SLD	Solid stomper
C908	Tray attachment pin
C913-1	Tray attachment bracket - Latch Type
C938SFT	Tray guard only (not sold separately) Order C938SFTA
C954S	Safety screen
C957-213	General instruction manual (not shown)
C977	SS standoff for tray guard
C980-3	Case cover
HHS025S	Hex head screw, ¼ - 20 x ½, SS
HN15S	Hex nut, ¼ - 20, SS
H374-1	Aluminum pop rivet for S/N plate
H442-1	Magnetic safety interlock switch, 230V to 600V
H653-E	Warning label, English
H653-SP	Warning label, Spanish
LW10S	Lock washer, ¼, SS
MC-410P	Bowl installation label
PC161	Strain relief fitting, (not shown)
16163A	Hold down clip
42MC-441	Warning label
42MC-Y20-8	Magnet, (not sold separately)
42MC-Y64	Magnetic safety interlock switch, to 230V, replaced H442
42MC-Y70	Safety switch bracket
42MC-Y71SOU	Hold down latch
42MC-Y72	Self retaining nut
42MC-Y73	Green push button assembly, replaced H482-1
42MC-Y74	Red push button assembly, replaced H482-2
42MC-Y75	“Start” legend plate
42MC-Y76	“Stop” legend plate

ASSEMBLIES

C912A	Tray assembly w/ guard & magnet complete - Spring type
C912-1A	Tray assembly w/ guard & magnet complete - Latch type
C938SFTA	Tray guard assembly w/ spacers & fasteners, must be welded by installer
C980A	Case assembly

BOWL, FRAME & MOTOR PARTS

C910K, MAIN DRIVE SHAFT KIT;
1 HP-ALL SERIAL NO'S.
1-1/2 HP-STARTING WITH SERIAL NO. 2388

C910-1K, MAIN DRIVE SHAFT KIT;
1-1/2 HP-BEFORE SERIAL NO. 2388

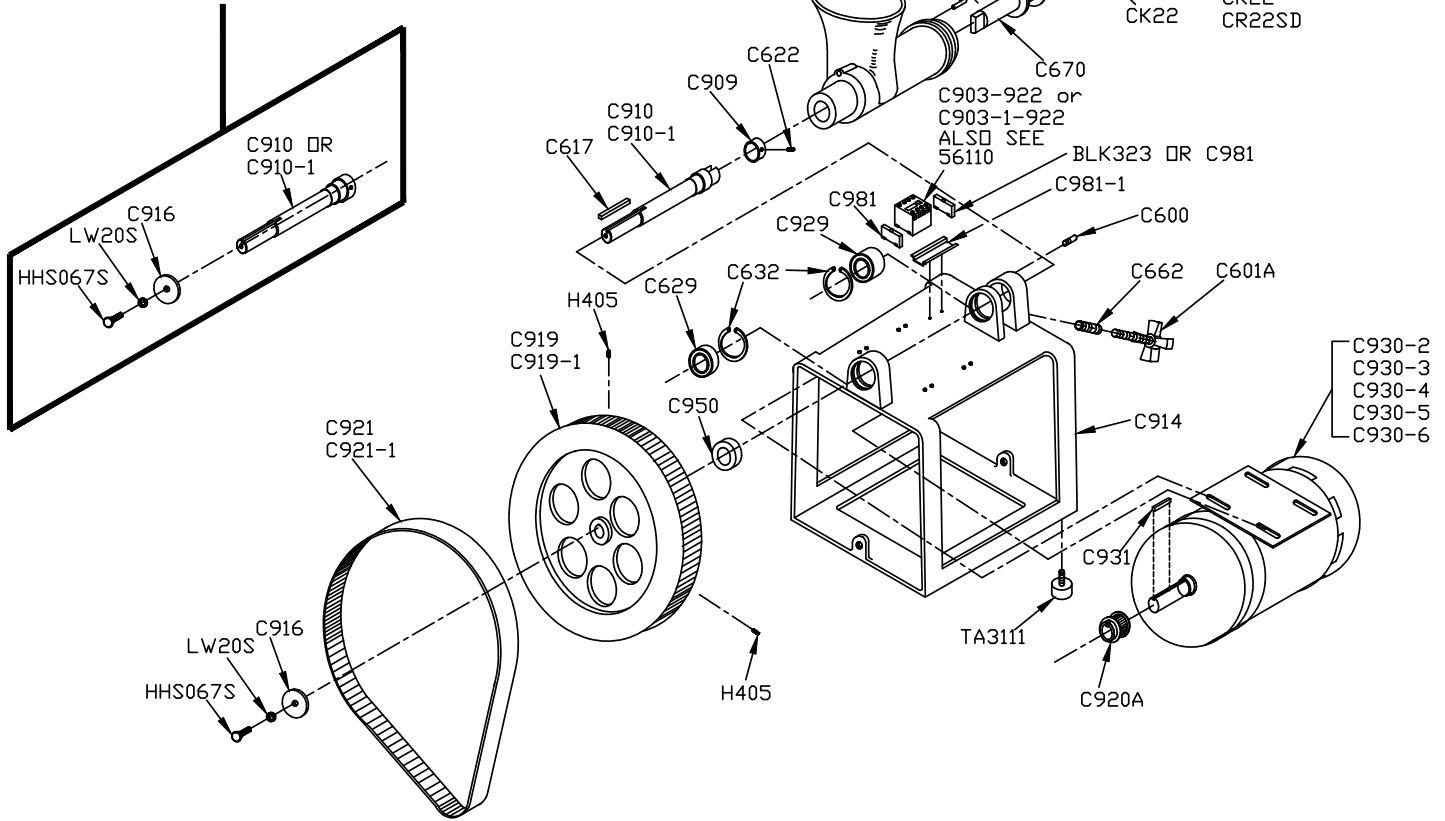

BOWL, FRAME & MOTOR PARTS LIST

NOTE: SPECIFY MODEL & SERIAL NUMBER WHEN ORDERING PARTS

Item No.	Description	Item No.	Description
BLK323 or C981	End clip for din rail, (2 Req'd)	C919-1	Main drive gear, 122T, 50Hz
CC220P	Grinding bowl	C920A	Motor pinion, 28T, 50/60Hz
CC220PS-1	Grinding bowl, S.S., straight	C921	HTD belt, 800-5M-30mm,60Hz
CK22	Knife drive pin, 1" round	C921-1	HTD belt, 710-5M-30mm,50Hz
CP22	Bowl pin, $\frac{3}{16} \times 1\frac{1}{8}$	C929	Front main bearing
CR22	End retaining ring	C930-2	Motor, 1HP, 220/440-50/60-3
CR22SD	End retaining ring, S.S., straight	C930-3	Motor, 1HP, 104/208-60-1
C600	Bowl locator pin, $\frac{5}{16}$ -18	C930-4	Motor, 1HP, 115/230-60-1
C617	Key, $\frac{1}{4} \times \frac{1}{4} \times 1\frac{7}{8}$ "	C930-5	Motor, 1HP, 240-50-1
C622	Shaft collar lock pin	C930-6	Motor, 1½ HP, 208/230-60-1
C629	Rear main bearing	C931	Motor key
C632	Retaining ring	C950	Shaft spacer, $\frac{5}{8}$ thick
C638	Motor stud, $\frac{5}{16} \times 1\frac{3}{8}$	C981-1	Din rail
C662	Heli-coil, $\frac{1}{2}$ "	HHS067S	Hex head screw, $\frac{3}{8}$ -16 x $\frac{3}{4}$
C670	Worm drive shaft	HN20S	Hex nut, $\frac{5}{16}$ -18, 60Hz motor
C903-922	Contact, 110V	H370	Hex nut, $\frac{5}{16}$ -18, (top of motor)
C903-1-922	Contact, 220V	LW20S	Lock washer, $\frac{3}{8}$, SS
C909	Upper shaft collar	TA3111	Rubber foot, 1", $\frac{1}{4}$ - 20, thread
C910	Order shaft kit, use C910K	56110	Transformer, 380,415,440V
C910-1	Order shaft kit, use C910-1K		
C910K	Main drive shaft kit, all 1 HP, & 1½ HP after 2388		
C910-1K	Main drive shaft kit, 1½ HP before 2388	CC220PA	ASSEMBLIES
C914	Aluminum grinder frame	CC220PS-1A	Open bowl assembly
C916	Flat washer	CS22A-R1	Open bowl assembly, S.S., straight
C919	Main drive gear, 148T, 60Hz	CS22SA-R2	Worm assembly
		C601A	Worm assembly, S.S., straight
			Bowl lock handle assembly

OPERATOR'S SIGNATURE PAGE

<p>WARNING READ AND UNDERSTAND THIS ENTIRE MANUAL BEFORE SIGNING BELOW</p>

MY SIGNATURE ATTESTS THAT I HAVE COMPLETELY READ AND UNDERSTAND THIS MANUAL. I REALIZE THAT THIS MACHINE, IF OPERATED CARELESSLY, CAN CAUSE SERIOUS INJURY TO MYSELF AND OTHERS.

NAME (PRINT)	SIGNATURE	SUPERVISOR'S INITIALS	DATE

LIMITED WARRANTY

WARRANTY: The BIRO Manufacturing Company warrants that the BIRO Model 922 Grinder will be free from defects in material and workmanship under normal use and with recommended service. BIRO will replace defective parts, which are covered by this limited warranty, provided that the defective parts are authorized for return, shipping charges prepaid, to a designated factory for inspection and/or testing.

DURATION OF WARRANTY: The warranty period for all parts covered by this limited warranty is one (1) year from date of Inspection/Demonstration as advised on the returned Warranty Registration card, or eighteen (18) months from original factory shipping date, whichever date occurs first, except as noted below.

PARTS NOT COVERED BY WARRANTY: The following are **not** covered by this limited warranty: wearable parts in the grinding system such as the bowl, worm drive shaft, ring, worm, and knife drive pin. This limited warranty does not apply to machines sold as used, rebuilt, modified, or altered from the original construction in which the machine was shipped from the factory. Water contaminated electrical systems are not covered under this limited warranty. BIRO is not responsible for electrical connection of equipment, adjustments to switch components or any other electrical requirements, which must be performed only by a certified electrician. BIRO is not responsible for service charges or labor required to replace any part covered by this limited warranty or for any damages resulting from misuse, abuse, lack of proper or recommended service.

EXCLUSION OF WARRANTIES AND LIMITATION OF REMEDIES: BIRO gives no warranties other than those expressly stated in this limited warranty. THE IMPLIED WARRANTY OF MERCHANTABILITY, THE IMPLIED WARRANTY OF FITNESS FOR PROCESSING OF FOOD PRODUCTS, AND ALL OTHER IMPLIED WARRANTIES ARE SPECIFICALLY EXCLUDED. BIRO IS NOT LIABLE FOR CONSEQUENTIAL OR INCIDENTAL DAMAGES, EXPENSES OR LOSSES. THE REMEDIES PROVIDED IN THIS BIRO LIMITED WARRANTY ARE PURCHASER'S SOLE AND EXCLUSIVE REMEDIES AGAINST BIRO.

REGISTRATION CARDS: You must sign, date and complete the warranty registration card supplied with each machine. The warranty card must be returned to The Biro Manufacturing Company for proper registration. If no warranty card is returned to BIRO, the warranty period will begin from the date the machine was originally shipped from the factory.

HOW TO GET SERVICE:

1. Contact the agency from whom you purchased the machine; or
2. Consult the yellow pages of the phone directory for the nearest authorized dealer; or
3. Contact Biro Mfg. Company for the nearest authorized service entity in your area.

BIRO MANUFACTURING COMPANY

1114 W Main Street
Marblehead, OH 43440
Ph. 419-798-4451
Fax 419-798-9106
Service@birosaw.com
www.birosaw.com