

# Sharpener Assembly

Complete Assembly

4675-01133

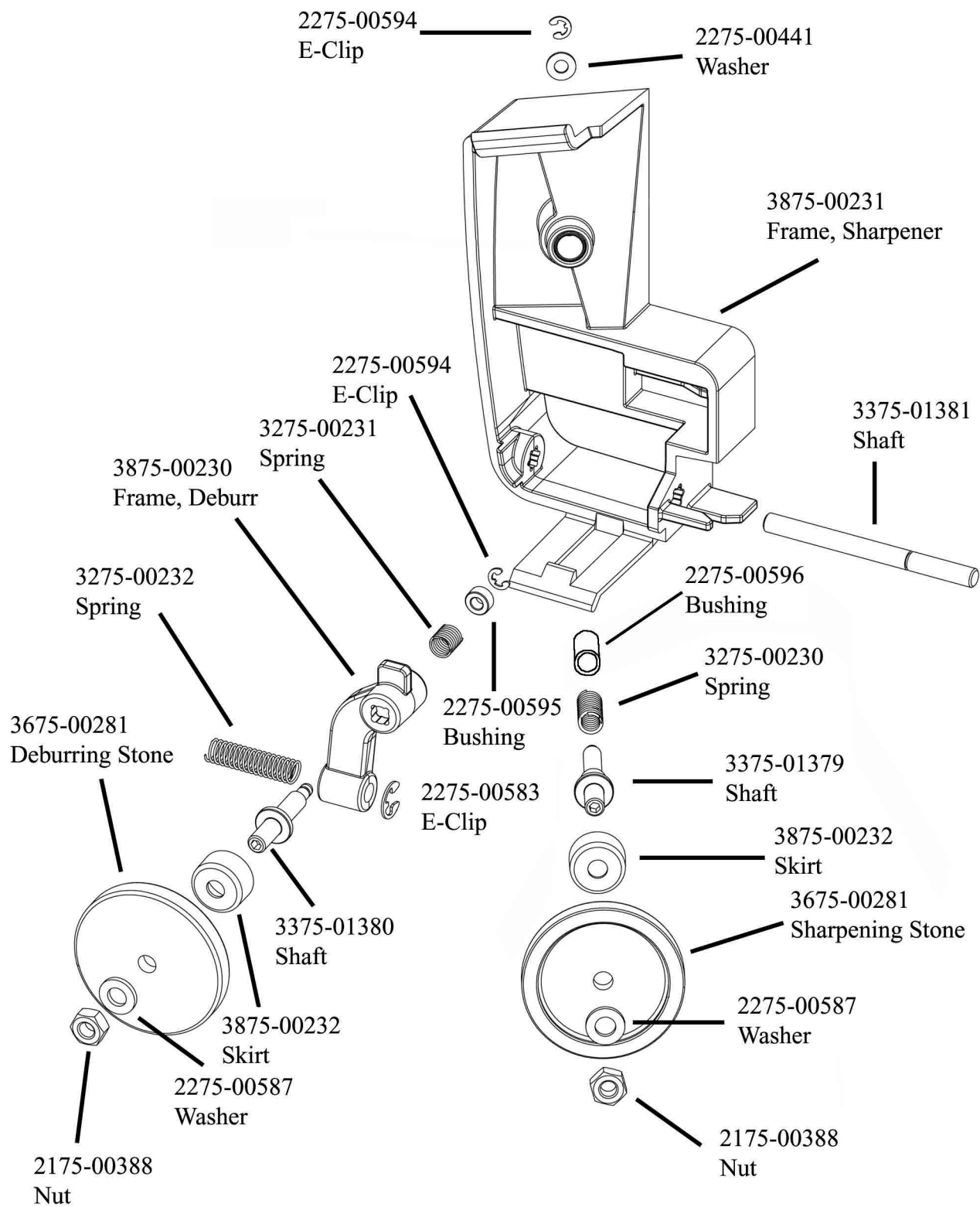

# Product Table

## Product Table Complete 4675-01134

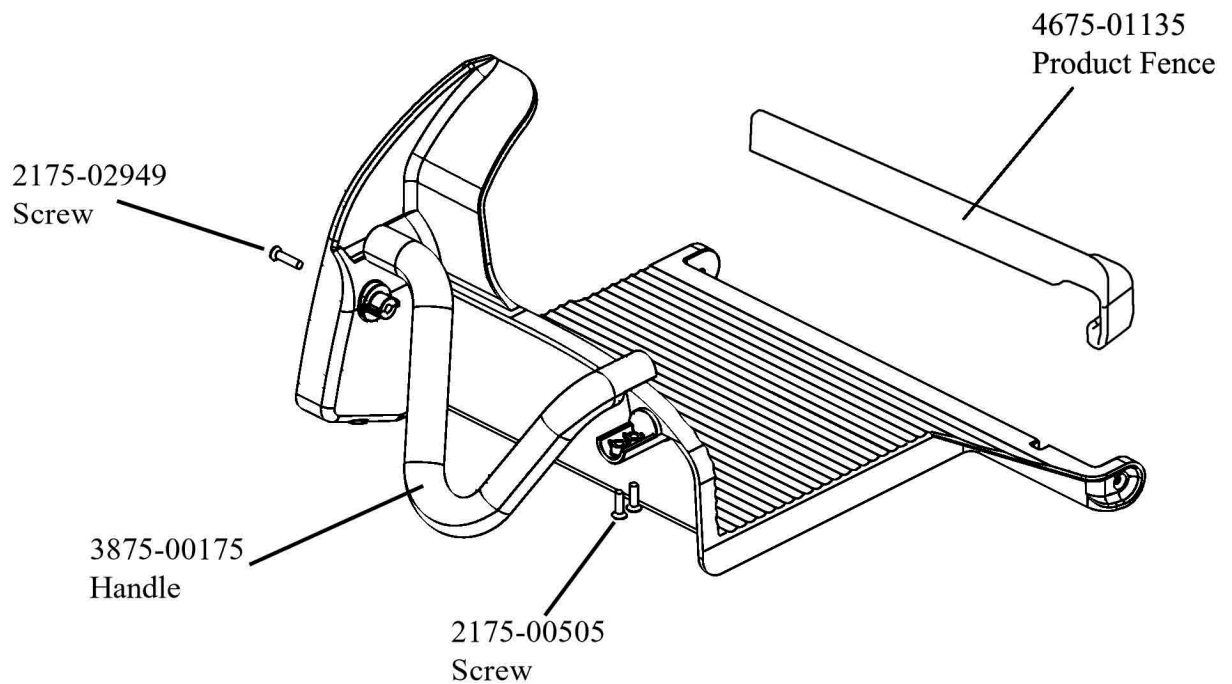
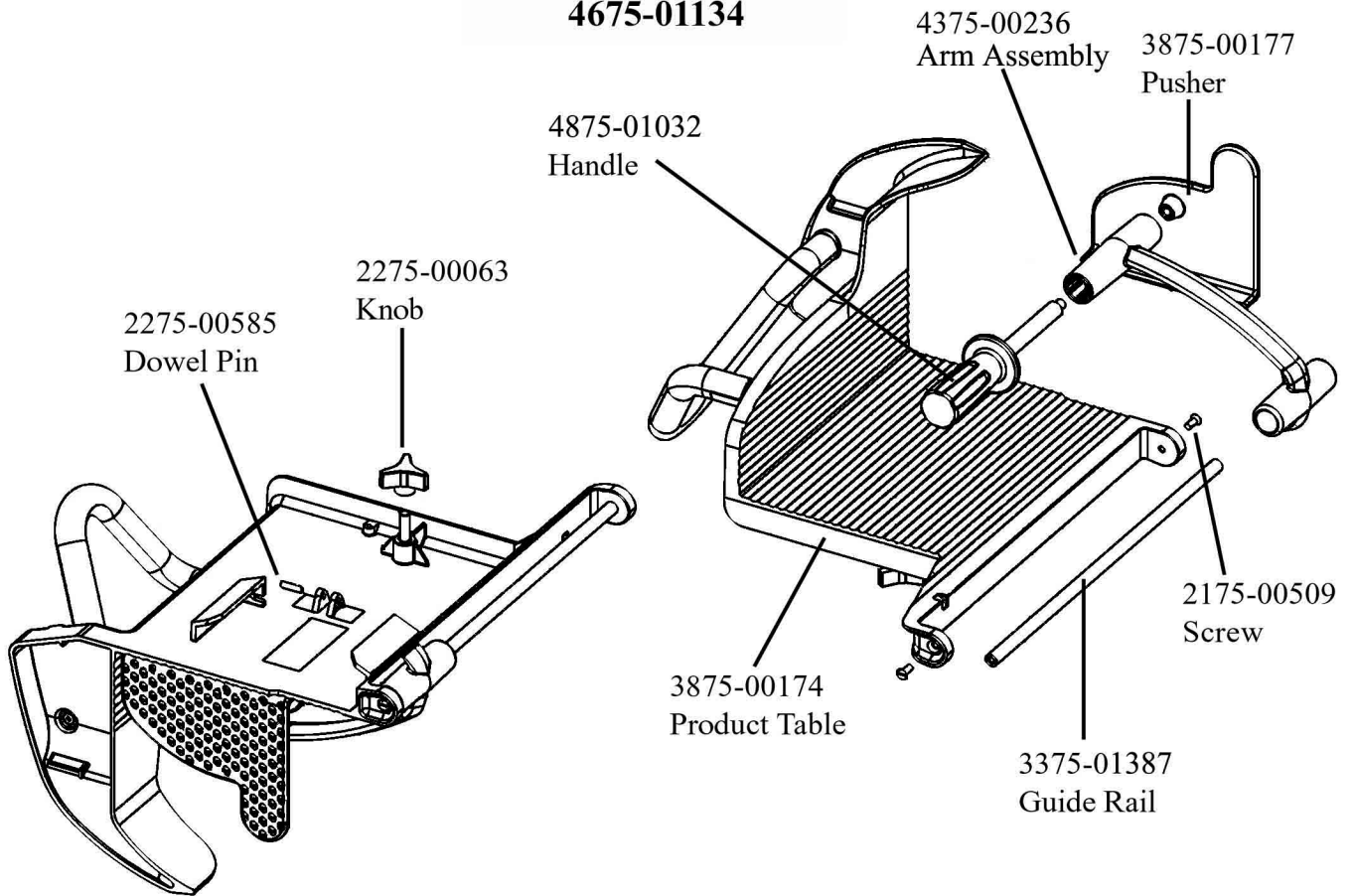

# Ring Guard and Center Plate

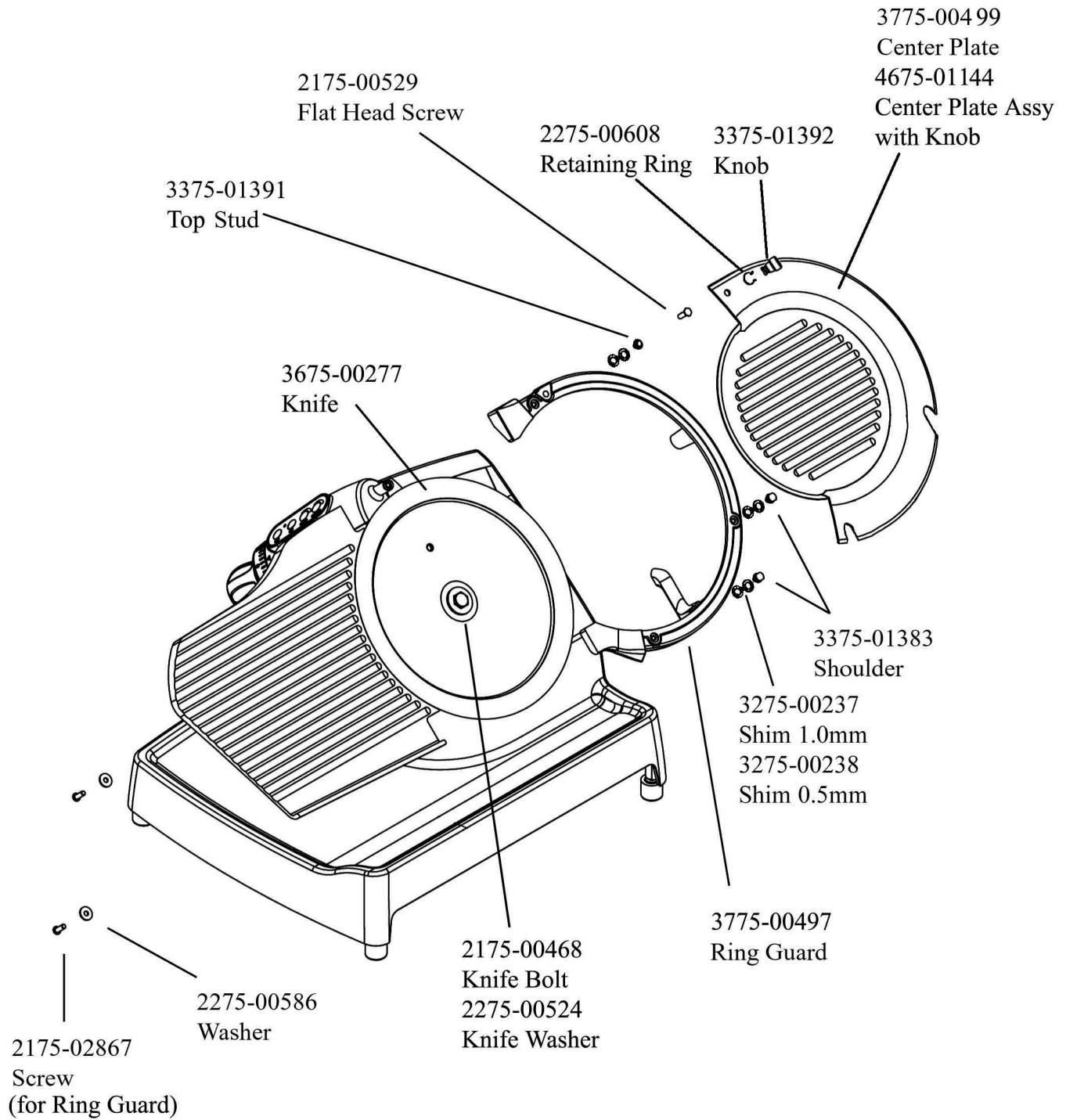

# Top Assembly 2

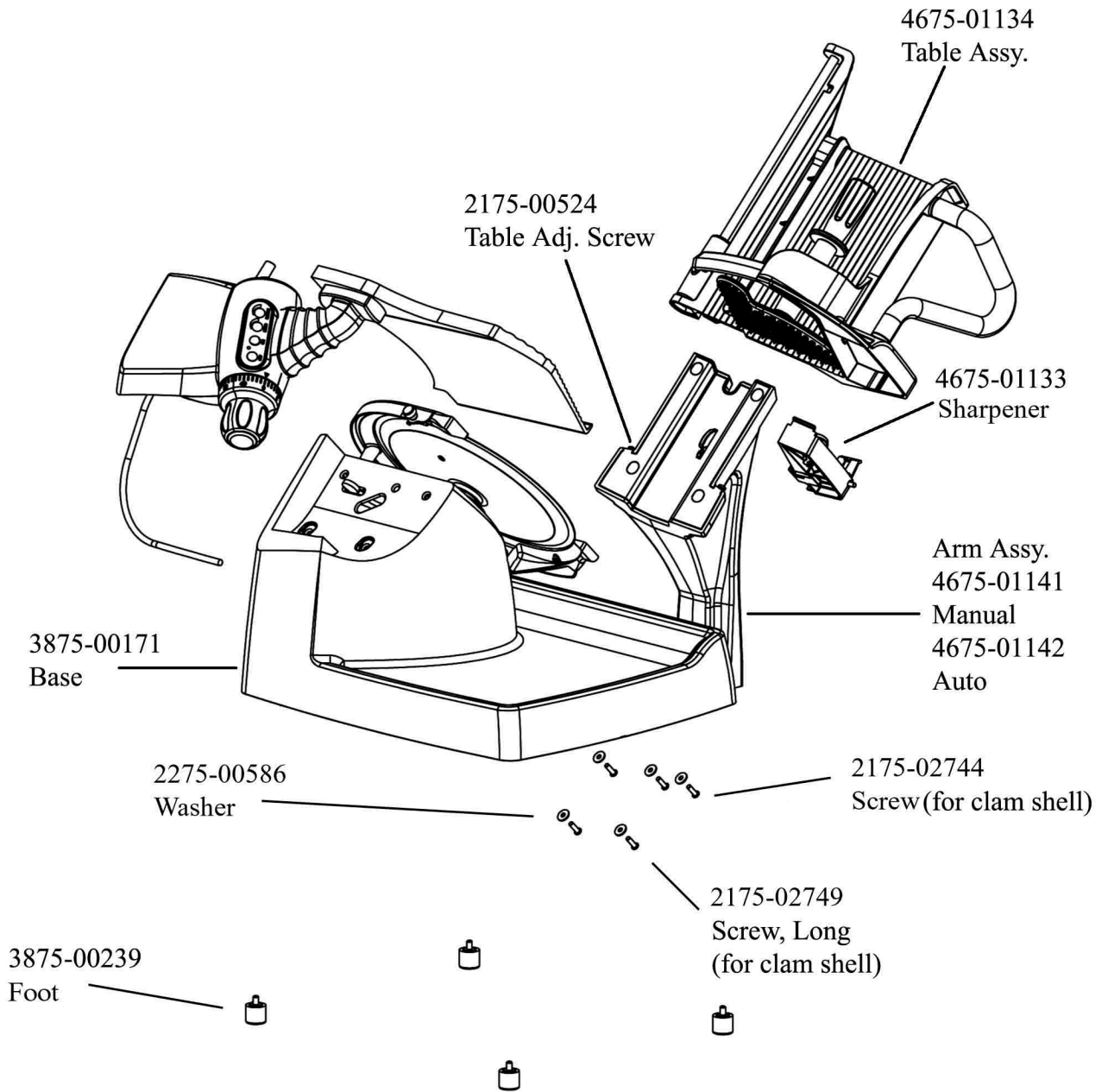

# Bottom View

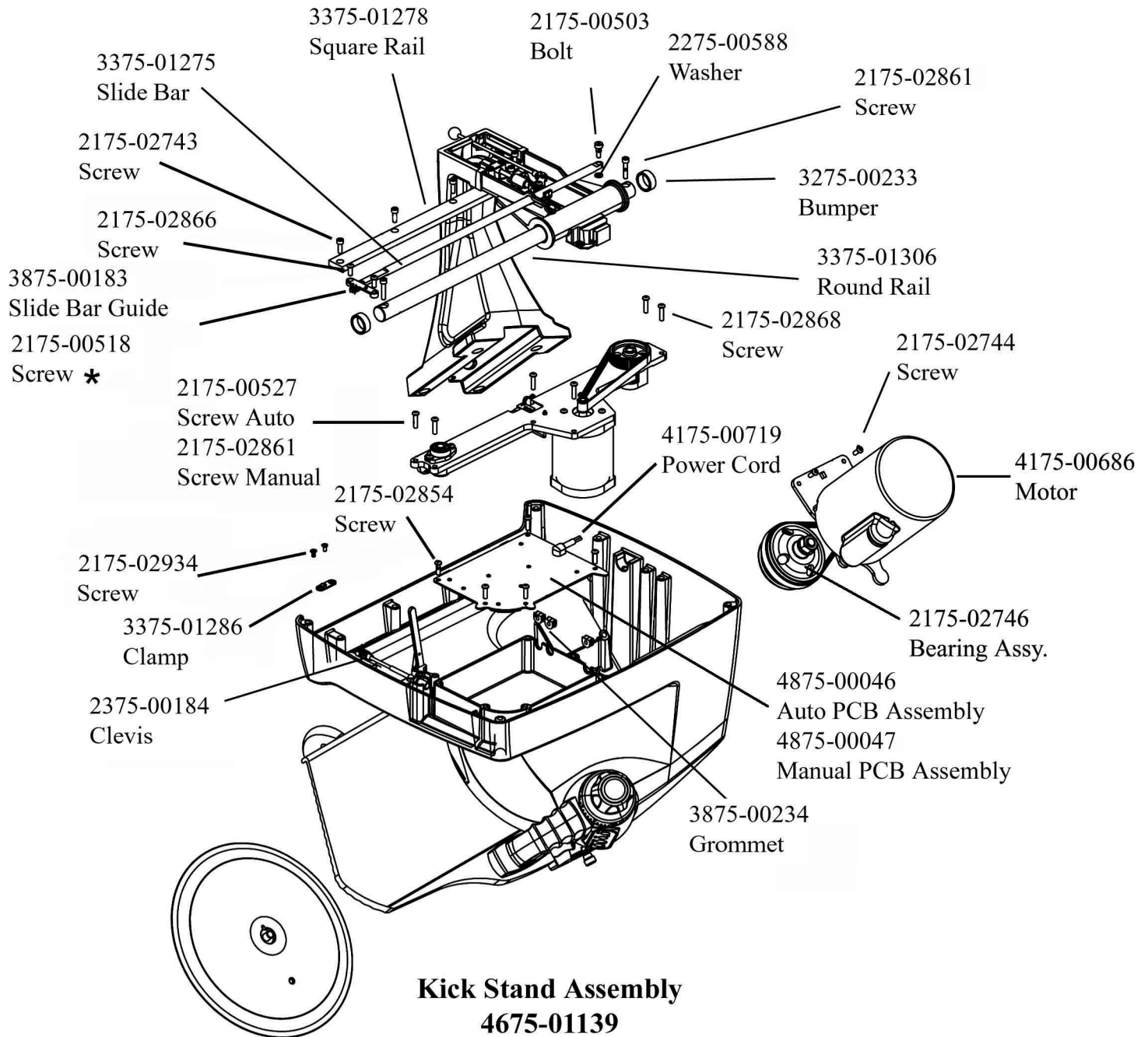

**\* Parts for Auto Slicer only**

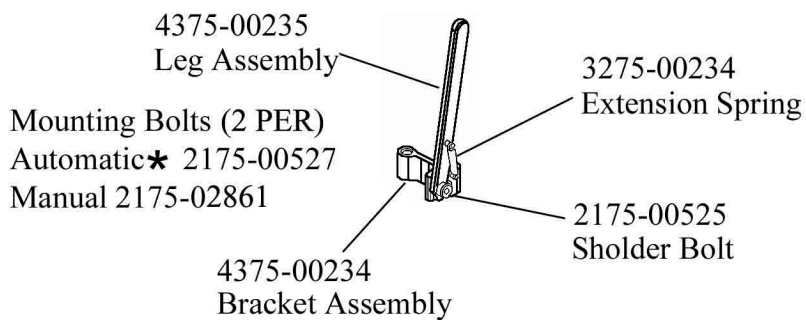

# Knife, Motor and Bearing Assembly

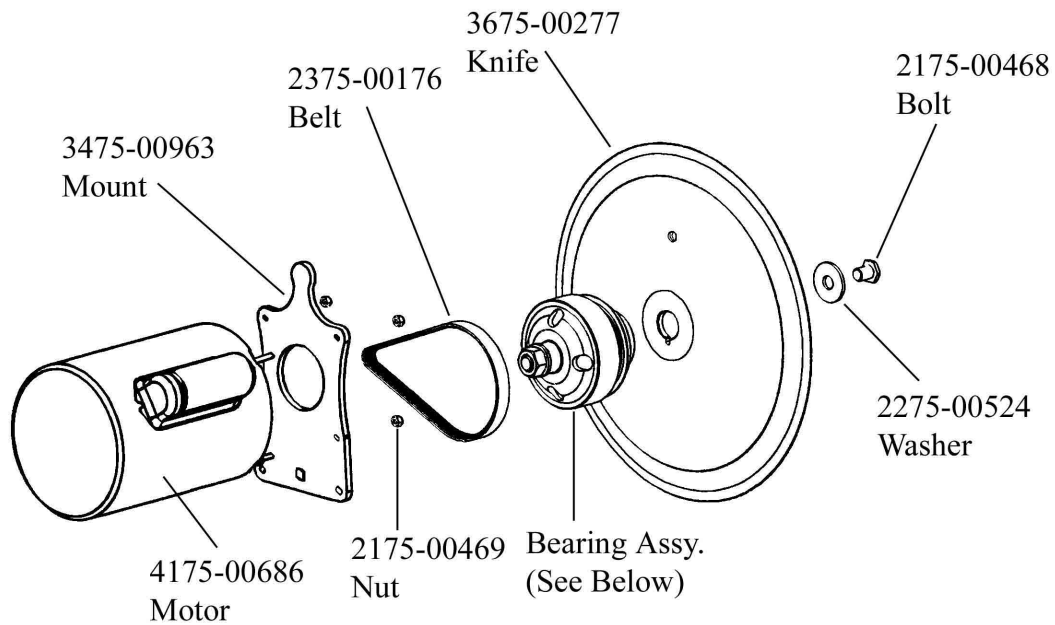

## Knife Bearing Assy. 4675-01140

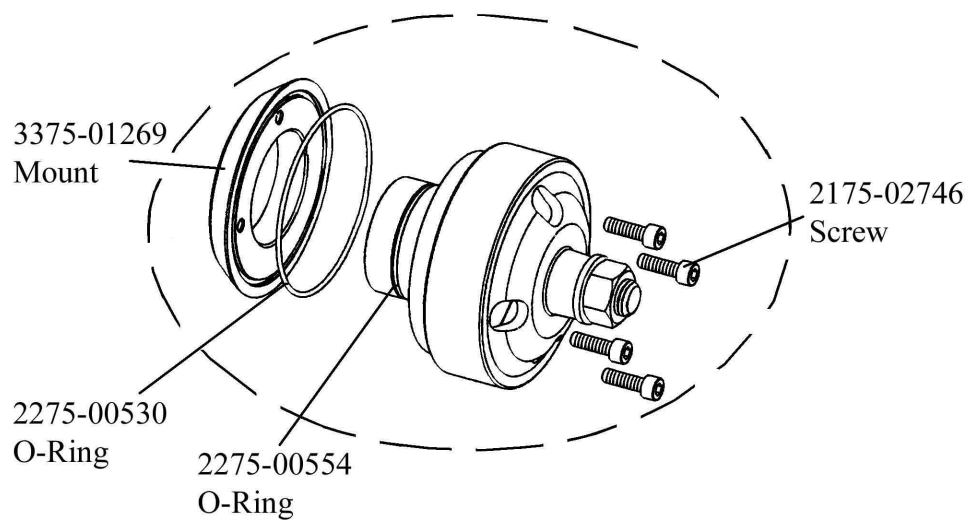

# Autodrive Assembly

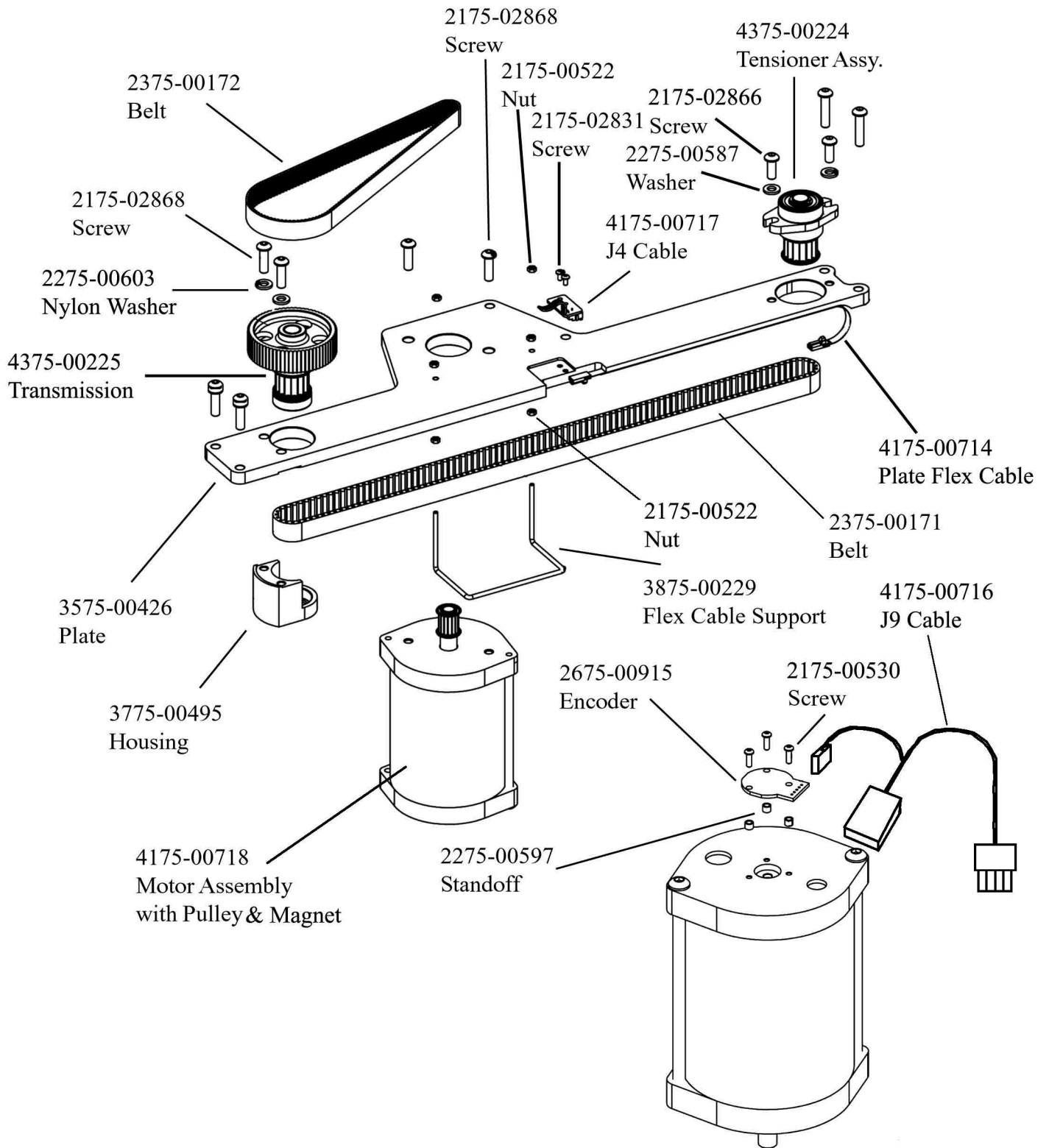

# Gauge Plate Assembly

## Complete Assembly

4675-01136

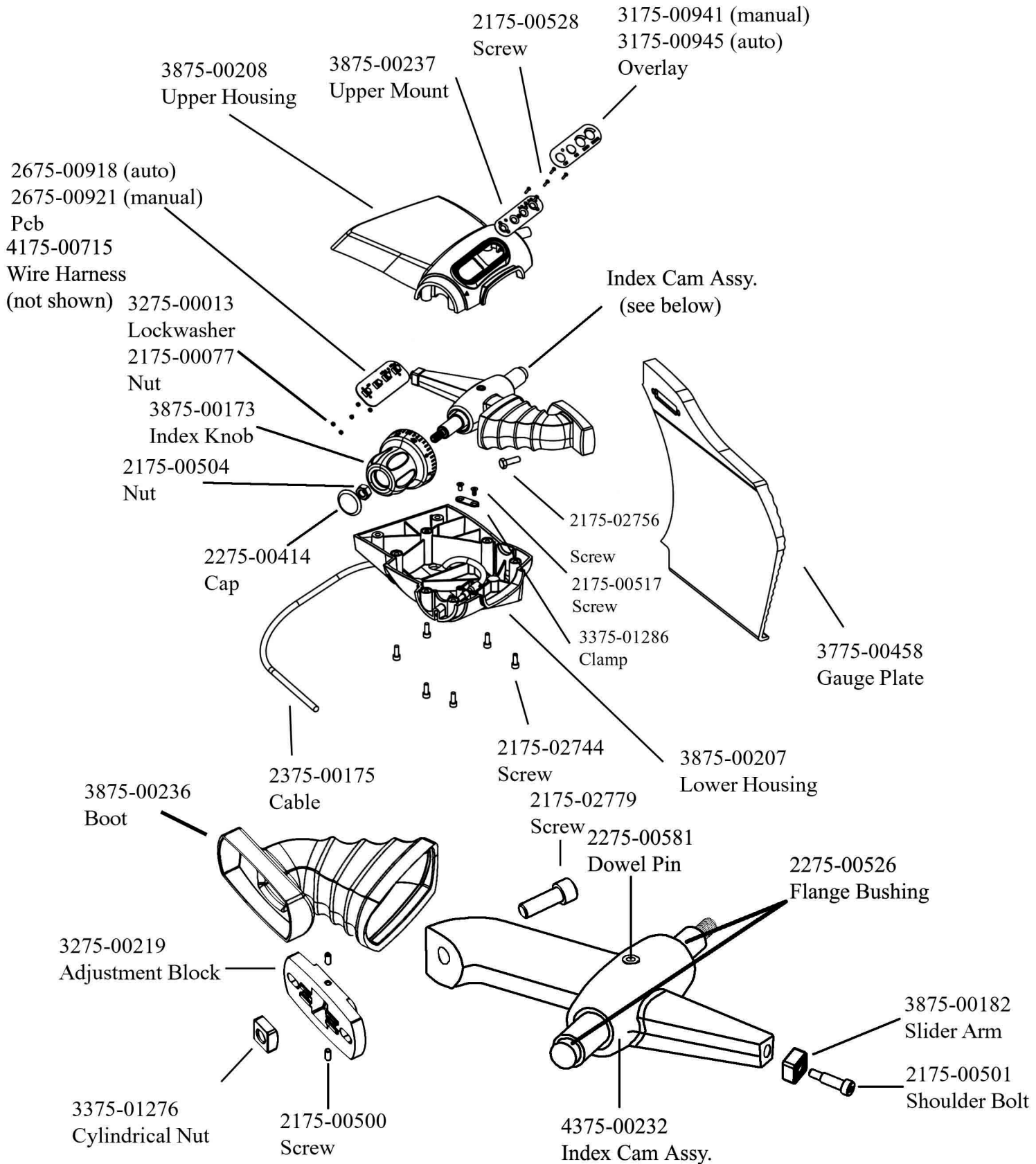



# Arm Assembly, Top View

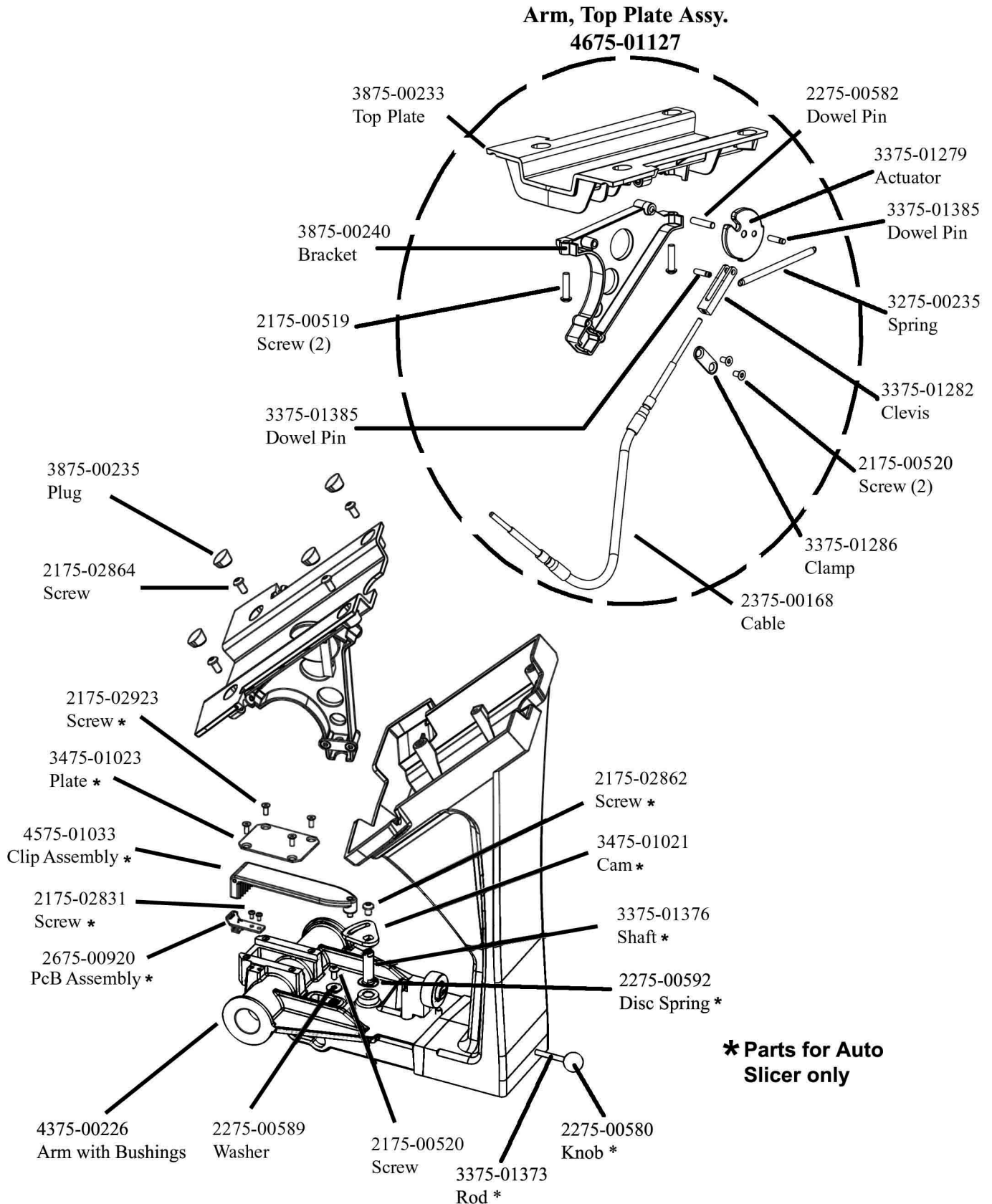

**\* Parts for Auto Slicer only**

# Arm Bottom

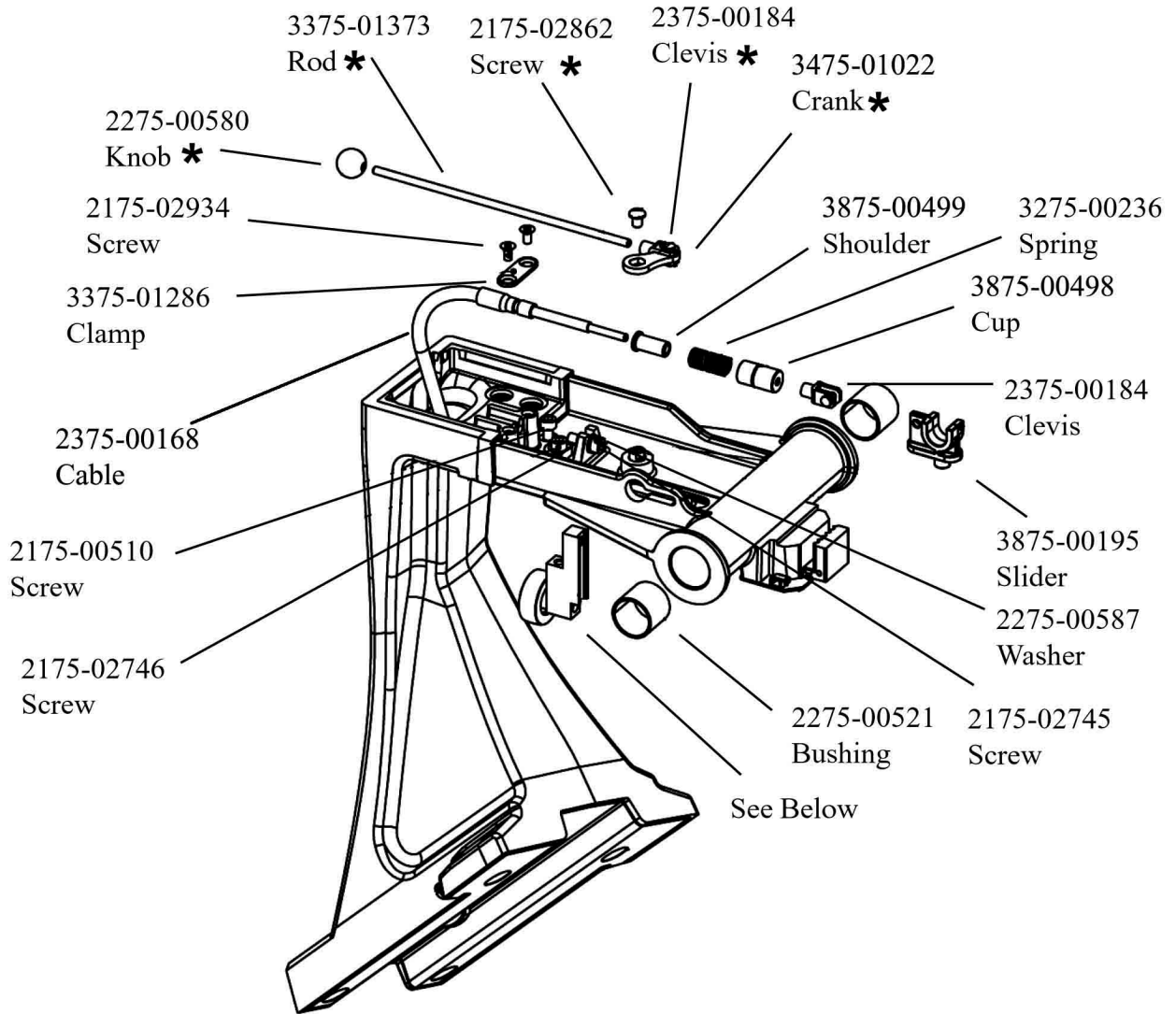

**\* Parts for Auto Slicer only**

